

ODISHA SKILL DEVELOPMENT AUTHORITY
Skill Development & Technical Education Department
World Skill Center, Block B, Sector A, Tower, 2010, Mancheswar Industrial Estate
Bhubaneswar-751007
Website: www.worldskillcenter.org, www.skillodisha.gov.in,
Email: tenders@worldskillcenter.org, Telephone: +91-674-2580079

Project Title: Odisha Skill Development Project
(ADB Loan No; 3539: IND)

Date: 24.04.2024

Subject: Addendum cum Proceedings of Virtual Pre – Bid Meeting held on 30th March 2024 at 11:00 AM IST for NCB Packages & Shopping Packages of OSDP

Ref: IFB Number: OSDA/WSC/Goods/M-8/2024 dated 14.03.2024 for Shopping and NCB Packages of Phase 8 Procurement.

1. A Virtual Pre-Bid meeting was held on 30th March 2024 at 11:00 AM for 10 NCB & 3 Shopping Packages under Phase VIII procurement for various labs at World Skill Center.
2. List of members present in the virtual meeting on behalf of OSDA and prospective bidders is enclosed in Annexure I and II respectively.
3. Dr. S. K. Das, Dy. Principal WSC, welcomed the participants and introduced the project, details of proposed NCB & Shopping packages to the prospective bidders.
4. The prospective bidders were briefed through a power point presentation containing the key points about the project, packages, instructions for submission of bids etc.

5. It was explained that bidders were free to participate in any one or more than one package in accordance with the instructions, procedures, eligibility criteria and terms and conditions of the bidding Document.
6. It was clarified that the bids are invited from eligible and qualified bidders under ADB's single stage two- envelope bidding procedure for all 10 NCB packages; under which bidders are required to submit Technical and Financial proposals in two separate envelopes in a specific order, manner and only specific formats, as explained in the bid document.
7. It was also clarified that eligible qualified bidders are required to submit bid in single envelope for all 3 Shopping packages under single stage single envelope bidding procedure.
8. It was further clarified that the bidders should provide Package wise Bid Security of required amount and validity in the prescribed format and non-refundable processing fees, as in ITB (Instruction to Bidders Sec — 1). The bidder's technical responsiveness shall be determined on the basis of parameters prescribed in Section 3: Evaluation and Qualification Criteria.
9. The financial proposals of only Technical Responsive bidders shall be opened. The bidders are advised to quote the rates after thorough study of the Bidding Document especially the specifications. Any discount offered on the quoted rates should be indicated in the Bid Form itself and not elsewhere; otherwise, that may not be considered in Bid Evaluation. Negotiations on quoted price will not be held under normal circumstances and therefore bidders should quote reasonable and competitive rates at the first instance.
10. The successful bidder shall have to deposit performance security in the form of an unconditional Bank Guarantee in the amount of Ten (10) percent of the Accepted Contract Price with validity to be enough to cover extended warranty period also.
11. It was also explained that conditional offers and late bids will not be accepted.
12. After the presentation, some prospective bidders raised few queries which were taken up by the officers of OSDA and ADB procurement expert.
13. Some prospective bidders sought clarification on the specifications in more detailed manner. It was suggested that the prospective bidders should send their queries in OSDA mail by 5:00 PM of 1st April 2024. These queries shall be compiled and addressed in the form of a corrigendum document and shall be uploaded on the website for information of all prospective bidders. The bidders were advised to view the project websites for regular updates.
14. The meeting ended with a vote of thanks to the chair and the members.

Encl: Annexure -I: List of officials on behalf of OSDA

Annexure -II: List of Prospective Bidders with contact details

Annexure -III: Addendum

Annexure – IV: Screen shot of participants.

Appendix – A to H

Sd/-
Chief Executive Officer
Odisha Skill Development Authority

ANNEXURE - I

LIST OF OFFICIALS ON BEHALF OF OSDA

1. Dr. Subhanga Kishore Das, Dy. Principal, WSC
2. Ms. Sushree Sasmita Sahoo, Course Manager (ACR), WSC
3. Mr. Dhananjaya Sarangi, CTO Cum IT Application Expert, OSDA
4. Mr. Chandan Kumar, GM-Procurement & Contract Management, OSDA
5. Mr. Sunil Kumar Goyal, Procurement expert and Consultant, ADB
6. Mr. Partha Mukherjee, IT, Infrastructure Expert, OSDA
7. Ms. Mitrakshi Mayurika Sahoo, M/WSC Campus-II
8. Ms. Swati Mishra, Nodal Officer/F& B, HO
9. Mr. Srikanta Patra, Nodal Officer/Digital Animation
10. Ms. Pragyan Panda, Nodal Officer/HCA
11. Mr. Bibhu Prasad Swain, Nodal Officer L&SCM
12. Mr. Sagar Kumar Tarai, Trainer, ACR

ANNEXURE - II

LIST OF PROSPECTIVE BIDDERS WITH CONTACT DETAILS

Sl. No.	Name of the Bidder	Name of the Representative	Email ID	Contact No.
1.	Shreeji Enterprises	Ms. Sapna Jena	shreeji.entp7@yahoo.in	9040533801 & 8908638111
2.	Labtech	Mr. Deepak Mehrotra	deepak@labtech.org	+919999470201
3.	Venture Enterprises	Mr. Sunil Sharma	sunil.ved@icloud.com	+91 9833608283
4.	Techmech engineers	Mr. Niranjan Mr. K Ananth	niranjan@techmechengineers.com ananth1308@gmail.com	9980002377 9900250083
5.	Festo India Pvt. Ltd.	Mr. Mohan. N	mohan.n@festo.com	8892583550
6.	Laerdal Medical India Pvt Ltd	Mr. Swaraj Mishra	swaraj.mishra@laerdal.com	8454948937
7.	Schneider Electric	Mr. Sehul Shah Mr. Amarnath Durgale	sehul.shah@se.com amarnath.durgale@se.com	9925330833 7406474259
8.	Pamtrons Healthcare Devices Mumbai	Mr. Paresh Modh	pamtron@yahoo.com	9820159016
9.	Mod Kitchen Equipment Pvt. Ltd.	Mr. Rohit Kumar (Director)	modequipment@yahoo.co.uk	9811085683
10.	FESTO India Pvt ltd	Mr. R. Ugesh	r.ugesh@festo.com	+91 9911167313

ANNEXURE – III

ADDENDUM -01

In reference to IFB OSDA/WSC/Goods/M-8/2024 dated 14.03.2024; following addendum is issued. Bidders are requested to submit the technical & Price bid as per the amended item numbers, description, quantity and technical specifications (as applicable) as per this addendum.

Sl. No.	Package No & Name	RFP Section /Clause No./Page No	Reference	Bidder's query/item where modification is proposed	OSDA Response/modification
1.	Common for all Packages	ITB 24.1 ITB 27.1	Deadline for Bid Submission	Bidders requested for Extension in the last date of Submission.	The last date of submission has been extended to 10th May 2024 - 2:00 PM (IST) – (Refer Corrigendum -02 dated 23.04.2024)
2.	Common for all Packages	ITB 27.1	Technical Bid Opening	Bid opening	The bid will be opened on the same day i.e. 10th May 2024 at 04:00 PM (IST). (Refer Corrigendum -02 dated 23.04.2024)
3.	Common for all Packages	Section 6	List of Goods and Related Services and Technical Specifications	Figures/Image/Drawing/Makes	The Figures/Image/Drawing/Makes, if any are only for indicative purpose. Bidders are required to submit names of specific make along with relevant product detail and technical specification under technical specification section and product quality will be determined on the basis of conformation of proposed technical specifications with minimum required specifications.
4.	Common for all Packages	Section 6	List of Goods and Related Services and Technical Specifications	Catalogues	Bidder are required to submit the catalogue containing proposed item by specifying make, product related details, technical specifications etc against each item.
5.	Common for all Packages	Section 4 -	Bidding Forms	Manufacturer Authorization	The bidder is allowed to submit authorization from manufacturer/Authorized dealer/Authorized

ANNEXURE – III

ADDENDUM -01

					supplier as the case may be.
6.	Common for all Packages	Section 4	Bidding Forms	Technical Bid Submission Sheet and Price Bid Submission Sheet	The bidders are required to submit Technical Bid Submission Sheet (TBSS) and Price Bid Submission Sheet (PBSS) by considering relevant Addendum related to each package.
PKG 0143- Training Equipment, Tools & Furniture for setting up of Food & Beverage Operations facility at WSC					
7.	PKG 0143- Training Equipment, Tools & Furniture for setting up of Food & Beverage Operations facility at WSC	Section 4 Section 6	Bidding Forms List of Goods and Related Services and Technical Specifications	<p>This package's major item specification does not exist. Provide us with accurate information and specifications, such as dimensions, set quantity details, etc.</p> <p>1.Manufacturer’s Authorization - It is difficult to provide a Manufacturer's Authorization for all items. We can get authorization from an Authorised Dealer. Many of the items have no details. Please provide me with the specifications.</p> <p>2.Many of the items have no details. Please provide me with the specifications.</p>	<p>1. Pl refer the Reply regarding Manufacturing authorization under Common points.</p> <p>2. The technical specification under section-6 of the bid document have been modified and replaced as Appendix A.</p>

ANNEXURE – III

ADDENDUM -01

PKG 0144- Training Equipment, Tools & Furniture for setting up of Hotel Operations facility at WSC.					
8.	PKG 0144- Training Equipment, Tools & Furniture for setting up of Hotel Operations facility at WSC	Section 6 Section 4	List of Goods and Related Services and Technical Specifications Bidding Forms	<p>This package’s major item specification does not exist. Provide us with accurate information and specifications, such as dimensions, set quantity details, etc.</p> <p>1.Manufacturer’s Authorization – It is difficult to provide a Manufacturer’s Authorization for all items. We can get authorization from an Authorised Dealer. Many of the items have no details. Please provide me with the specifications.</p> <p>2.Many of the items have no details. Please provide me with the specifications.</p>	<p>The technical specification under section 6 of the bid document have been modified and replaced as Appendix – B.</p> <ol style="list-style-type: none"> 1. Pl refer the Reply regarding Manufacturing authorization under Common points. 2. The technical specification under section-6 of the bid document have been modified and replaced as Appendix B.
PKG 0145- Training Equipment, Tools & Furniture for setting up of Digital Animation Facility at WSC					
9.	PKG 0145- Training Equipment, Tools & Furniture for setting up of Digital Animation Facility at WSC	Section 4 Section 6	Bidding Forms Technical Specification	<p>1.Manufacturer’s Authorization – It is difficult to provide a Manufacturer’s Authorization for all items. We can get authorization from an Authorised Dealer.</p> <p>2. Many of the items have no details. Please provide with the specifications.</p>	<ol style="list-style-type: none"> 1. Pl refer the Reply regarding Manufacturing authorization under Common points 2. The technical specification under section 6 of the bid document have been modified and replaced as Appendix C

ANNEXURE – III

ADDENDUM -01

10.	PKG 0145- Training Equipment, Tools & Furniture for setting up of Digital Animation Facility at WSC	Section 6: Item B3	List of Goods and Related Services and Technical Specifications3D Sculpting Software	A lot of OEMs have this software. Please confirm which one you are looking for. Need proper details, subscription type,	Please refer Appendix-C
11.	PKG 0145- Training Equipment, Tools & Furniture for setting up of Digital Animation Facility at WSC	Section 6: Item B4	List of Goods and Related Services and Technical SpecificationsSubstance Painter Software	Need proper details, subscription type,	Please refer Appendix-C
12.	PKG 0145- Training Equipment, Tools & Furniture for setting up of Digital Animation Facility at WSC	Section 6: Item B7	List of Goods and Related Services and Technical SpecificationsAdobe cloud creative suite	There is a lot of applications with this name, so please let me know which one you need exactly.	Please refer Appendix-C
13.	PKG 0145- Training Equipment, Tools & Furniture for setting up of Digital Animation Facility at WSC	Section 1	ITB 14.8- If so indicated in ITB 1.1, Bids are being invited for individual contracts (lots) or for any combination of contracts (packages). Unless otherwise indicated in the BDS, prices quoted shall correspond to 100% of the items specified for each lot and to 100% of	With reference to the ITB No.14.8 of PKG-0145, we would like to request you to kindly allow to quote individual items or allow item wise evaluation for the said Package. As we are IT vendors and we have better experience in IT products but in your tender there are many Non-IT items which will restrict IT product dealers in participating the tender. Please consider the same for more competitive bidding.	Conditions of bidding document shall prevail

ANNEXURE – III

ADDENDUM -01

			the quantities specified for each item of a lot.		
14.	PKG 0145- Training Equipment, Tools & Furniture for setting up of Digital Animation Facility at WSC	Section 7	GCC 18.1- The Supplier shall provide a Performance Security of 10 percent of the Contract Price. The Performance Security shall be denominated in the following amounts and currencies: The amounts and currencies shall be in proportion to the amounts and currencies of the contract price.	We request you to kindly make the Performance Security 5% of the total contract value. In order to make the tender more competitive kindly reduce the Performance Security to 5%.	Conditions of bidding document shall prevail
15.	PKG 0145- Training Equipment, Tools & Furniture for setting up of Digital Animation Facility at WSC	Section 6: Item 85	List of Goods and Related Services and Technical Specifications of the Items (No.11-A2)- Colour Scanner	With reference to the technical Specifications of the Workstation, we request you to kindly make the following changes: Resolution: 4800dpi optical; 9600dpi enhanced –Please change it to--- 600 dpi optical and 600 dpi hardware. USB and parallel port connectivity -----Please change it to--- Connectivity- 10/100/1000 Ethernet; 1 Hi-Speed USB Host (rear); 1 Hi-Speed USB Host (walk-up) as the current specification	Please refer Appendix-C

ANNEXURE – III

ADDENDUM -01

				has already been obsolete and advance technology is available with all OEMs Remarks: In order to make it more competitive bidding	
16.	PKG 0145- Training Equipment, Tools & Furniture for setting up of Digital Animation Facility at WSC	Section 6 : Item 84	List of Goods and Related Services and Technical Specifications of the Items (No.10-A1)- PC Workstation	With reference to the technical specifications of the PC workstation, we request you to remove the Point No.- 3 of the Additional Software Remarks: In order to make it more competitive bidding	Please refer Appendix-C
17.	PKG 0145- Training Equipment, Tools & Furniture for setting up of Digital Animation Facility at WSC	Section 6: Item 84	List of Goods and Related Services and Technical Specifications of the Items (No.10-A1)- PC Workstation (Form Factor with Tool free design)	With reference to the technical specifications of the PC workstation, we request you to Change it to Convertible Mini Tower/Tower with tool-less entry and maintenance. System should feature Active Acoustic Reduction, with low noise level. Remarks: In order to make it more competitive bidding	Please refer Appendix-C
18.	PKG 0145- Training Equipment, Tools & Furniture for setting up of Digital Animation Facility at WSC	Section 6: Item 83	List of Goods and Related Services and Technical Specification of the Items (No.10-A1)- PC Workstation (Ports)	With reference to the technical Specifications of the PC Workstation, we request you to kindly make the following specifications as minimum in the Ports(No.14) : Front I/O – 2 x Type-A SuperSpeed USB 10Gbps signalling rate port (1 charge port supports up to 5V/2.1A), 2 x Type-A SuperSpeed USB 10Gbps signalling rate port, 1 x	Please refer Appendix-C

ANNEXURE – III

ADDENDUM -01

				<p>Type-C SuperSpeed® USB 20Gbps signalling rate port (charge supports up to 5V/3A,), Optional 1 x SD card reader , 1 universal audio jack</p> <p>Rear I/O – 2 x Display Port , 1 x Audio Line out, 1 x Audio Line in, 1 x RJ-45, 3 x Hi-Speed USB 480Mbps signalling rate port, 2 x Type-A SuperSpeed USB 10Gbps signalling rate port, 1 x Type-A SuperSpeed USB 5Gbps signalling rate port,1x1GbE LAN</p> <p>Remarks: In order to make it more competitive bidding</p>	
19.	PKG 0145- Training Equipment, Tools & Furniture for setting up of Digital Animation Facility at WSC	Section 6	List of Goods and Related Services and Technical Specifications of the Items (No.10-A1)- PC Workstation (Ports)	Also we request you kindly confirm the Monitor size /specification as no monitor is mentioned in the technical specifications of the PC Workstation. Please confirm whether it with or without monitor.	Please refer Appendix-C
20.	PKG 0145- Training Equipment, Tools & Furniture for setting up of Digital Animation Facility at WSC	Section 2	<p>Bid Data Sheet</p> <p>ITB 21.1 – The Bidder shall furnish a bid security in the form of Bank Guarantee of Amount INR 14,62,587 or \$14,205 with validity of 210 days from deadline of the bid submission date or</p>	<p>Request you to make it minimum INR 6 Lakhs and also allow the EMD/Bid security exemption option for MSME certificate holders.</p> <p>Remarks: In order to make it more competitive bidding</p>	Conditions of bidding document shall prevail

ANNEXURE – III

ADDENDUM -01

			Demand Draft of same amount.		
21.	PKG 0145- Training Equipment, Tools & Furniture for setting up of Digital Animation Facility at WSC	Section 6	List of Goods and Related Services and Technical Specifications: For computer workstations	<p>With reference to the above tender number and NCB Packages, we would like to request you to kindly add the following Point for the Computer Workstations so that none of the bidders can manipulate</p> <ul style="list-style-type: none"> • The compliance for computer Workstations need to be submitted on the OEMs Letterhead with signed and stamped by the local sales Authority. <p>Remarks: for fair and competitive bidding.</p>	Conditions of bidding document shall prevail
PKG 0146- Training Equipment, Tools & Furniture for setting up of Healthcare Assistant Training Facility at WSC					
22.	PKG 0146- Training Equipment, Tools & Furniture for setting up of Healthcare Assistant Training Facility at WSC	Section 6	List of Goods and Related Services and Technical Specifications	1. Many of the items have no details. Please provide with the specifications.	The technical specification under section 6 of the bid document have been modified and replaced as Appendix D

ANNEXURE – III

ADDENDUM -01

PKG 0147- Training Equipment, Tools & Furniture for setting up of Logistics & Supply Chain Management Facility at WSC					
23.	PKG 0147- Training Equipment, Tools & Furniture for setting up of Logistics & Supply Chain Management Facility at WSC	Section 6	List of Goods and Related Services and Technical Specifications	Many of the items have no details. Please provide with the specifications.	The technical specification under section 6 of the bid document have been modified and replaced as Appendix E
24.	PKG 0147- Training Equipment, Tools & Furniture for setting up of Logistics & Supply Chain Management Facility at WSC	Section 6: Item A4 Console (with 4 outputs and 6 outputs)	List of Goods and Related Services and Technical Specifications 400W Power Output Detachable 8-Channel Mixer 2 x Two-Way Bass Reflex Speakers with wireless mike	The specification is not clear; additional information is required.	Please refer Appendix-E
25.	PKG 0147- Training Equipment, Tools & Furniture for setting up of Logistics & Supply Chain Management Facility at WSC	Section 6: Item D1 Bag Compartment Shelf	List of Goods and Related Services and Technical Specifications No data	Size required. Please provide the drawings	Please refer Appendix-E

ANNEXURE – III

ADDENDUM -01

26.	PKG 0147- Training Equipment, Tools & Furniture for setting up of Logistics & Supply Chain Management Facility at WSC	Section 6 : Item D2 Display Table	List of Goods and Related Services and Technical Specifications No data	Size required. Please provide the drawings	Please refer Appendix-E
27.	PKG 0147- Training Equipment, Tools & Furniture for setting up of Logistics & Supply Chain Management Facility at WSC	Section 6 : Item D3 Extension cords, cables	List of Goods and Related Services and Technical Specifications No data	How many sockets are required in a single extension box?	Please refer Appendix-E
28.	PKG 0147- Training Equipment, Tools & Furniture for setting up of Logistics & Supply Chain Management Facility at WSC	Section 6 : Item D6 Printer table	List of Goods and Related Services and Technical Specifications No data	length size is required.	Please refer Appendix-E
29.	PKG 0147- Training Equipment, Tools & Furniture for setting up of Logistics & Supply Chain Management Facility at WSC	Section 6 : Item A10 Safety Shoes	List of Goods and Related Services and Technical Specifications “Length - Low ankle Insole Material-PU Feature-Chemical Resistant, Heat Resistant	Size required.	Please refer Appendix-E

ANNEXURE – III

ADDENDUM -01

			Ankle Length-Low Ankle With Lining-Yes Steel toe cap-Provided, Length Low ankle		
30.	PKG 0147- Training Equipment, Tools & Furniture for setting up of Logistics & Supply Chain Management Facility at WSC	Section 6 : Item C3 Wooden Pallet	List of Goods and Related Services and Technical Specifications No data	Size required	Please refer Appendix-E
31.	PKG 0147- Training Equipment, Tools & Furniture for setting up of Logistics & Supply Chain Management Facility at WSC	Section 6 : Item C4 Compressed Wood Pallet	List of Goods and Related Services and Technical Specifications No data	Size required	Please refer Appendix-E
32.	PKG 0147- Training Equipment, Tools & Furniture for setting up of Logistics & Supply Chain Management Facility at WSC	Section 6 :	List of Goods and Related Services and Technical Specifications Many of the item no details. Please provide me the specification.	Kindly provide us with more specification details.	Please refer Appendix-E

ANNEXURE – III

ADDENDUM -01

PKG 0148: Training Equipment, Tools & Furniture for setting up of Spatial Artificial Intelligence Training Facility at WSC					
33.	PKG 0148: Training Equipment, Tools & Furniture for setting up of Spatial Artificial Intelligence Training Facility at WSC	Section 6	List of Goods and Related Services and Technical Specifications; Many of the item has no details. Please provide the specification.	Kindly provide us with more specification details.	The technical specification under section 6 of the bid document have been modified and replaced as Appendix F
PKG 0150- IT Equipment for setting up of COE in Industrial Automation & Smart Manufacturing at WSC					
34.	PKG 0150- IT Equipment for setting up of COE in Industrial Automation & Smart Manufacturing at WSC	Section 6; Item A3 Computer Server without monitor	Technical Specifications Processor Intel Xeon 2.20GHz <ul style="list-style-type: none">• 32 GB RAM• 2 TB storage• 4 Gigabit ethernet ports	<ol style="list-style-type: none">1. Need a server type, such as tower or rackmount.2. Please confirm whether a Windows server is necessary or not. If necessary, please specify the Windows server version.3. Please provide us with complete specification details.	<ol style="list-style-type: none">1.Type of the server is Tower type.2. Yes windows server is necessary. Version is Server 2019.3. Specification of Server 2019

ANNEXURE – III

ADDENDUM -01

PKG 0151: Training Equipment & Tools for setting up of COE in Industrial Automation at WSC					
35.	PKG 0151: Training Equipments & Tools for setting up of COE in Industrial Automation at WSC	Section 4 Page 4-7: Price Schedule for Goods to Be Offered from Within the Purchaser's Country & Page 4-9: Price Schedule for Goods to Be Offered from Outside the Purchaser's Country	Bidding Forms A4: Universal automation software/ Automation Simulation Software - team license - 5 no	The item number and description are mismatched w.r.t. the scope of supply	To be read as: A4: Training Kit for SCADA application - 5 nos.
36.	PKG 0151: Training Equipments & Tools for setting up of COE in Industrial Automation	Section 4 Page 4-7: Price	Bidding Forms A5: Digital Twin developer software - team license - 10 nos.	The item number and description are mismatched w.r.t. the scope of supply	To be read as: A5: automation software/Automation Simulation Software - team license - 10 nos.

ANNEXURE – III

ADDENDUM -01

	at WSC	Schedule for Goods to Be Offered from Within the Purchaser's Country & Page 4-9: Price Schedule for Goods to Be Offered from Outside the Purchaser's Country			
37.	PKG 0151: Training Equipments & Tools for setting up of COE in Industrial Automation at WSC	Section 6 Page 6-2: List of Goods and Related Services and Technical Specification s: 1: Training kit for HMI +	List of Goods and Related Services and Technical Specifications The didactic package designed to.. maximum 10days from the date of the call/email.	The 16 switches will be wired as Digital Inputs to simulate various faults, pls confirm Please confirm if the following applications should be part of the supply: 1. Since the Analog sensor kit is already a separate line item in the BOM comprising of the analog sensors, pls clarify whether additional sensors have to be supplied along with the training kit for HMI and PLC 2. Pls clarify water level controller and the servo	All the digital and analog IO to be wired out on the surface plate using 4mm banana sockets. And from there the IO's can be connected using 4mm banana patch cords to simulate different fault conditions. 1. No need to supply the additional analog sensors kit along with this item, as these are already specified in a separate line item A3. 2. Please note, only 01 No of the water level controller as defined in the tender to be supplied

ANNEXURE – III

ADDENDUM -01

		PLC with software License		drive application should be part of the supply	against this line item. 3. Please note, only 05 Nos of the of Servo Drive application as defined in the tender to be supplied against this line item.
38.	PKG 0151: Training Equipments & Tools for setting up of COE in Industrial Automation at WSC	Page 6-11: Additional Requirements Under the Scope of Supply: Joint Certification	List of Goods and Related Services and Technical Specifications The bidder shall agree to provide joint certification for every trainee of every course conducted and completed at CoE in Industrial Automation.	OEM certification will be more useful for the students, hence request to consider OEM certification instead of bidder's	Accepted. The Joint Certification point under Section 6 is modified and to be read as follows: Section 6: List of Goods and Related Services and Technical Specifications Additional Requirements Under the Scope of Supply: Joint Certification After successful completion of every course conducted at CoE in Industrial Automation, the bidder must provide course completion certificate for every trainee, certified jointly by OEM and WSC.
PKG 0152- Training Simulator of CNC for Precision Engineering at WSC					
39.	PKG 0152- Training Simulator of CNC for Precision Engineering at WSC	Section 3	Evaluation and Qualification Criteria Eligible Bidders: Under 2.2(2.2.1), 2.3(2.3.1)	Will ADB scrutinise a bidder if ever he has failed to perform his duties post receiving of PO from State Units of GOI?	Yes. Please refer Section 4 - Bidding Forms, Technical bid Submission Sheet, Point No i.

ANNEXURE – III

ADDENDUM -01

40.	PKG 0152- Training Simulator of CNC for Precision Engineering at WSC	Section 6	Eligible Goods and Related Services:	Will ADB give benefit for MII products?	Conditions of bidding document shall prevail
41.	PKG 0152- Training Simulator of CNC for Precision Engineering at WSC	Section 6	List of Goods and Related Services and Technical Specifications Suggestion of MII equipment.	Will ABD look into MII equipment so as to get unlimited warranty & regular updates & unhindered service?	Conditions of bidding document shall prevail
42.	PKG 0152- Training Simulator of CNC for Precision Engineering at WSC	Section 3	Evaluation and Qualification Criteria 2.4 Financial Situation 2.4.2	MSME cannot meet these criteria as product cost for tendered are not always high in value but high in numbers. We suggest quality of bidder be given more importance over value. Eg: total number of similar equipment sold can be 2 to 3 times higher, in working condition. Latest certificate from top 5 customers. Etc. This will confirm good quality equipment to WSC for its current & future use.	Conditions of bidding document shall prevail
43.	PKG 0152- Training Simulator of CNC for Precision Engineering at WSC	Section 6	1. List of Goods & Related Services & Tech Specs	The suggestive picture on the bid depicts a product that has been only & only used by the company for its internal training. It has no record to show its single installation in the country (INDIA). WE SUGGEST BRAND VEMCO A PRODUCT OF INDIA & AUSTRIA WHICH HAS BEEN	The technical specification under section 6 of the bid document have been modified and replaced as Appendix G

ANNEXURE – III

ADDENDUM -01

				<p>PROVEN BETTER & HAS APPROX INSTALLATION OF APPROPX 500 SUCH SIMULATORS I THE COUNTRY.IT GIVES YOU UNLIMITED UPGRADE COMES WITH BACKUP FORM ORIGINAL CONTROL MANUFACTURERS. HAS 100% FUNCTIONAL OF THE EQUIPMENT SUPPLIED SINCE 20 ODD YEARS.</p>	
44.	<p>PKG 0152- Training Simulator of CNC for Precision Engineering at WSC</p>	<p>Section 3 Page No.: 37</p>	<p>Evaluation and Qualification Criteria</p> <p>2.3 Experience and Technical Capacity</p> <p>2.3.1 Contractual Experience Criteria Requirement</p> <p>Successful completion as a main reputed manufacturer/authorized supplier of reputed manufacturer within the last 5 calendar years from the bid publishing (IFB) date, of at least 3 contracts each valued of</p>	<p>at least 3 contracts each valued of calculated cost of INR 1,07,90,000/USD 1,30,000/ EUR 1,20,000 or at least 2 contracts.....</p>	<p>Conditions of bidding document shall prevail</p>

ANNEXURE – III

ADDENDUM -01

			<p>calculated cost of INR 1,43,26,215/USD 1,72,605 or at least 2 contracts each valued of calculated cost of INR 1,79,07,748/USD 2,15,756 or 1 contract of cost of INR 2,68,61,622 or USD 3,23,634 with nature, and complexity similar to the scope of supply described in Section 6 (Schedule of Supply)</p>		
45.	<p>PKG 0152- Training Simulator of CNC for Precision Engineering at WSC</p>	<p>Section 3 Page No.: 60</p>	<p>Evaluation and Qualification Criteria Form EXP-1: Contractual Experience Description of the Similarity in Accordance with Criteria 2.3.1(Contract Type B) of Section 3 (Evaluation and Qualification Criteria) Successful completion as</p>	<p>at least 3 contracts each valued of calculated cost of INR 1,07,90,000/USD 1,30,000/ EUR 1,20,000 or atleast 2 contracts.....</p>	<p>Conditions of bidding document shall prevail</p>

ANNEXURE – III

ADDENDUM -01

			<p>a main reputed manufacturer/authorized supplier of reputed manufacturer within the last 5 calendar years from the bid publishing (IFB) date, of at least 3 contracts each valued of calculated cost of INR 1,43,26,215/USD 1,72,605 or at least 2 contracts each valued of calculated cost of INR 1,79,07,748/USD 2,15,756 or 1 contract of cost of INR 2,68,61,622 or USD 3,23,634 with nature, and complexity similar to the scope of supply described in Section 6 (Schedule of Supply)</p>		
--	--	--	---	--	--

ANNEXURE – III

ADDENDUM -01

46.	PKG 0152- Training Simulator of CNC for Precision Engineering at WSC	Section 6 Page No.: 77	2.Delivery and Completion Schedule T+90 days	T+180 days Remarks: Principal supplier requires 4 months, The software & hardware to be imported by DMG MORI India and supply to WSC	Conditions of bidding document shall prevail
47.	PKG 0152- Training Simulator of CNC for Precision Engineering at WSC	Section 8 Page No.: 101	Special Conditions of Contract GCC 16.1 (a) Advance Payment: 10% of the Contract Price within 28 days of signing of the Contract. Payment shall be made provided the Supplier presents a request for payment accompanied by an Advance Payment Security in the form of a bank guarantee for an amount equal to the amount of the payment,	(a) Advance Payment: 30% of the contract Price payment accompanied by an AGB Common Remarks for Page 101 queries: Goods will be imported by DMG MORI and supply to WSC	Conditions of bidding document shall prevail

ANNEXURE – III

ADDENDUM -01

			and that shall be valid until the Goods are delivered. The security shall be in the form as specified in Section 9 (Contract Forms). This advance amount needs to be recovered/adjusted before release of final payment on Acceptance (10% of the Contract Price)		
48.	PKG 0152- Training Simulator of CNC for Precision Engineering at WSC	Section 8 Page No.: 101	Special Conditions of Contract GCC 16.1 (b) On Delivery: The Purchaser shall pay the Supplier 70% of the Contract Price of the Goods, after delivery at site/location and upon submission of documents specified in SCC Clause 12.1.	(b) On Delivery: 60% of the contract Price with taxes against submission of PI before shipment Remarks: Software supplier has to be paid 100% against Proforma Invoice before dispatch	Conditions of bidding document shall prevail

ANNEXURE – III

ADDENDUM -01

49.	PKG 0152- Training Simulator of CNC for Precision Engineering at WSC	Section 8 Page No.: 101	Special Conditions of Contract GCC 16.1 For Goods and Related Services supplied from within the Purchaser's country I After substantial completion (Installation and Commissioning) of related services: 20% of the Contract Price of Goods shall be paid immediately after satisfactory Installation and Commissioning (Except Training).	10% of the contract Price of Goods shall be paid immediately after satisfactory installation & Training	Conditions of bidding document shall prevail
50.	PKG 0152- Training Simulator of CNC for Precision Engineering at WSC	Section 8 Page No.: 101	Special Conditions of Contract GCC 16.1 For Goods and Related Services supplied from within the Purchaser's country		Conditions of bidding document shall prevail

ANNEXURE – III

ADDENDUM -01

			(d) On Acceptance: 10% of the Contract Price of Goods received shall be paid after successful training and upon submission of a claim supported by the acceptance certificate issued by the Purchaser.		
51.	PKG 0152- Training Simulator of CNC for Precision Engineering at WSC	Section 8 Page No.: 110	Special Conditions of Contract GCC 18.1 The Supplier shall provide a Performance Security of 10 percent of the Contract Price. The Performance Security shall be denominated in the following amounts and currencies: The amounts and currencies shall be in proportion to the amounts and currencies of the contract price	Performance Security for 3 percent Remarks: Scope of requirement consists of softwares, request to consider 3%	Conditions of bidding document shall prevail

ANNEXURE – III

ADDENDUM -01

52.	PKG 0152- Training Simulator of CNC for Precision Engineering at WSC	Section 7 Page No.: 103	General Conditions of Contract GCC 27.1 The maximum amount of liquidated damages shall be: 10%	The maximum amount of liquidated damages shall be: 5% Remarks: Requirement consists of software, request to consider 5%	Conditions of bidding document shall prevail
53.	PKG 0152- Training Simulator of CNC for Precision Engineering at WSC	Section 6 Page No.: 70 Technical Clarification – Scope of Supply 1. List of Good and Related Services and Technical Specifications A3 – Digital Twin for Education basic package/Equivalent	- List of Goods and Related Services and Technical Specifications . Control software Fanuc 31i Turn+Mill, Siemens 840D Turn+Mill, Heidenhain (Itnc 640) Turn+Mill & Fagor 8055 Turn+Mill	Digital Twin software for Siemens 840D Turn +Mill, Heidenhain (Itnc640) Turn + Mill	Please Refer Appendix G

ANNEXURE – III

ADDENDUM -01

54.	PKG 0152- Training Simulator of CNC for Precision Engineering at WSC	<p>Section 6 Page No.: 70</p> <p>Technical Clarification – Scope of Supply</p> <p>1. List of Good and Related Services and Technical Specifications A3 – Digital Twin for Education basic package/Equivalent</p>	List of Goods and Related Services and Technical Specifications.	<p>Control software Fanuc 31i Turn+Mill, Siemens 840D Turn+Mill, Heidenhain (Itnc 640) Mill</p> <p>Remarks: Heidenhain Turning is not much used and hence not recommended. For the Model 8055, Fagor do not have any offline simulator. Moreover, this software is not popular in India as most of the machine tool builders do not use this control</p>	Please Refer Appendix G
55.	PKG 0152- Training Simulator of CNC for Precision Engineering at WSC	<p>Section 6 Page No.: 71</p> <p>A1 PC/CNC Offline Simulator</p>	List of Goods and Related Services and Technical Specifications.	<p>1. Must provide for the following controls and technologies:</p> <ul style="list-style-type: none"> - Fanuc turning and milling. - Siemens 840 D Turning and milling. - Heidenhain TNC640 Milling. <p>Remarks: As mentioned in the above remarks. Most of the training centre focus on Fanuc, Siemens and Heidenhain controls and technologies</p>	Please Refer Appendix G

ANNEXURE – III

ADDENDUM -01

			<ul style="list-style-type: none"> - Siemens 840 D Turning and milling. - Heidenhain TNC640 Turning and milling. - Fagor 8055 Turning and milling. 		
PKG 0153- Equipment for Setting up of IT infrastructure for Precision Engineering at WSC					
56.	PKG 0153- Equipment for Setting up of IT infrastructure for Precision Engineering at WSC	Section 1 items 14 & 30	<p>ITB 14.8- If so indicated in ITB 1.1, Bids are being invited for individual contracts (lots) or for any combination of contracts (packages). Unless otherwise indicated in the BDS, prices quoted shall correspond to 100% of the items specified for each lot and to 100% of the quantities specified for each item of a lot.</p>	<p>With reference to the ITB No.14.8 of PKG-0153, we would like to request you to kindly allow to quote individual items or allow item wise evaluation for the said Package. As we are IT vendors and we have better experience in IT products but in your tender there are many Non-IT items which will restrict IT product dealers in participating the tender. Please consider the same for more competitive bidding.</p>	<p>Conditions of bidding document shall prevail</p>

ANNEXURE – III

ADDENDUM -01

57.	PKG 0153- Equipment for Setting up of IT infrastructure for Precision Engineering at WSC	Section 3 :	2.Qualification Criteria (2.3.1- Contractual Experience- Successful completion as a main reputed manufacturer/authorized supplier of reputed manufacturer within the last 5 calendar years from the bid publishing (IFB) date, of at least 3 contracts each valued of calculated cost of INR 2,44,80,452/USD 294,945 or at least 2 contracts each valued of calculated cost of INR 3,06,00,565/USD 368,682 or 1 contract of cost of INR 4,59,00,847 or USD 5,53,022 with nature, and complexity similar to the scope of supply described in Section 6 (Schedule of Supply).	With reference to the Qualification Criteria (No.2.3.1)- we would like request you to kindly make 3 contracts each valued of calculated cost of INR 2 cr. Or above	Conditions of bidding document shall prevail
-----	--	-------------	---	--	--

ANNEXURE – III

ADDENDUM -01

58.	PKG 0153- Equipment for Setting up of IT infrastructure for Precision Engineering at WSC	Section 7 : page 107	<p>GCC 18.1- The Supplier shall provide a Performance Security of 10 percent of the Contract Price. The Performance Security shall be denominated in the following amounts and currencies: The amounts and currencies shall be in proportion to the amounts and currencies of the contract price.</p>	<p>We request you to kindly make the Performance Security 5% of the total contract value. In order to make the tender more competitive kindly reduce the Performance Security to 5%.</p>	Conditions of bidding document shall prevail
59.	PKG 0153- Equipment for Setting up of IT infrastructure for Precision Engineering at WSC	Section 6: Item 72	<p>List of Goods and Related Services and Technical Specifications . Technical Specifications of the Items (No.29-A2.1)- Workstation</p>	<p>With reference to the technical Specifications of the Workstation, we request you to kindly make the following specifications as minimum in the Ports(No.14): Front I/O – 2 x Type-A SuperSpeed USB 10Gbps signalling rate port (1 charge port supports up to 5V/2.1A), 2 x Type-A SuperSpeed USB 10Gbps signalling rate port, 1 x Type-C SuperSpeed® USB 20Gbps signalling rate port (charge supports up to 5V/3A,), Optional 1 x SD card reader , 1 universal audio jack Rear I/O – 2 x Display Port , 1 x Audio Line out, 1 x Audio Line in, 1 x RJ-45, 3 x Hi-Speed USB</p>	<p>Please read as: Number of USB Version 3 .1, Gen 2 Ports 3 or more Number of USB Type C Ports 1 or more Number of Mini DP Ports 2, 4, 6, 8, 12, 3, 9, 16 Or higher Number of DP Ports 1, 2, 3, 4, 6, 8, 9, 12, 16 Or higher HDMI Port (Optional) 1x1GbE LAN</p>

ANNEXURE – III

ADDENDUM -01

				<p>480Mbps signalling rate port, 2 x Type-A SuperSpeed USB 10Gbps signalling rate port, 1 x Type-A SuperSpeed USB 5Gbps signalling rate port, 1x1GbE LAN</p> <p>Remarks: In order to make it more competitive bidding</p>	
60.	<p>PKG 0153- Equipment for Setting up of IT infrastructure for Precision Engineering at WSC</p>	<p>Section 6 : item 75</p>	<p>List of Goods and Related Services and Technical Specifications .</p> <p>Technical Specifications of the Items (No.29-A2.1)- Workstation</p>	<p>With reference to the technical specifications of the workstation, we request you to remove the Point No.- III of the serial No.18</p> <p>Remarks: In order to make it more competitive bidding</p>	<p>Conditions of bidding document shall prevail</p>
61.	<p>PKG 0153- Equipment for Setting up of IT infrastructure for Precision Engineering at WSC</p>	<p>Section 6 : Item 77</p>	<p>List of Goods and Related Services and Technical Specifications.</p> <p>Technical Specifications of the Items (No.30-A3.1)- Mono Printer</p>	<p>Request you to kindly remove the Wi-Fi option of the printer as this specification is only available with only one OEM-Canon which will restrict other reputed OEMs to participate in the tender.</p> <p>Remarks: In order to make it more competitive bidding</p>	<p>Conditions of bidding document shall prevail</p>
62.	<p>PKG 0153- Equipment for Setting up of IT infrastructure for Precision Engineering at WSC</p>	<p>Section 1</p>	<p>ITB 21.1 – The Bidder shall furnish a bid security in the form of Bank Guarantee of Amount INR 12,24,023 or</p>	<p>Request you to make it INR 6 Lakhs and also allow the EMD/Bid security exemption option for MSME certificate holders.</p> <p>Remarks: In order to make it more competitive</p>	<p>Conditions of bidding document shall prevail</p>

ANNEXURE – III

ADDENDUM -01

			\$14,747 with validity of 210 days from deadline of the bid submission date or Demand Draft of same amount.	bidding	
63.	PKG 0153- Equipment for Setting up of IT infrastructure for Precision Engineering at WSC	Section 6	List of Goods and Related Services and Technical Specifications . For computer workstations	With reference to the above tender number and NCB Packages, we would like to request you to kindly add the following Point for the Computer Workstations so that none of the bidders can manipulate <ul style="list-style-type: none"> The compliance for computer Workstations need to be submitted on the OEMs Letterhead with signed and stamped by the local sales Authority. Remarks: for fair and competitive bidding.	Conditions of bidding document shall prevail
64.	PKG 0153- Equipment for Setting up of IT infrastructure for Precision Engineering at WSC	Section 6 A1.4	List of Goods and Related Services and Technical Specifications. 2MP IP Dome Camera 2 Megapixel 30m View Distance Ethernet Connectivity HDD 3.5 inch SATA 6 Gb/s	You want full for one set quantity or only the camera. need clarification in this.	The total quantity of camera to be supplied is 34 Nos. Please refer Section 6 , Point no A1.4 for detailed Specification and quantity.

ANNEXURE – III

ADDENDUM -01

			5400 RPM 256 MB Cache NVR 32 Support for 32 Channel Camera Input support H264 Video format Resolution 1080p		
65.	PKG 0153- Equipment for Setting up of IT infrastructure for Precision Engineering at WSC	Section 6 Item A1.6	List of Goods and Related Services and Technical Specifications . Cat-6 UTP Cable 4 Pair 23 AWG Solid Copper Conductors with FR Grade or Equivalent. Characterized upto 600Mhz. Conductor: Solid Bare Copper, AWG: 23, Temperature: Max 75°C.	1. Length each box is not specified. Please let me know in one box how much length is required. 2. This is just the supply or installation that you require. If installation is required, we need a routing drawing.	1. Length of each box is 305 Mtrs. 2. Both Supply and Installation Routing drawings shall be provided at a later stage
66.	PKG 0153- Equipment for Setting up of IT infrastructure for Precision Engineering at WSC	Section 6	List of Goods and Related Services and Technical Specifications .	This bundle includes a large amount of electrical and installation work, so we just need to supply or install it.	Both Supply and Installation needs to be done by the Supplier.

ANNEXURE – III

ADDENDUM -01

<p>67.</p>	<p>PKG 0153- Equipment for Setting up of IT infrastructure for Precision Engineering at WSC</p>	<p>Section 6 A6.1 Interactive Smart Projector</p>	<p>Delivery and Completion Schedule Integrated Blended Smart Classroom hardware with Multi Classroom Collaboration Software, Classroom Lecture Capture Software & Interactive Digital Wall Software. Related services: The Related services includes cost of transportation, loading, unloading, insurance, spare parts for maintenance, tools for operation, cost for 3 years complete warranty, commissioning, staff training</p>	<p>Bhubaneshwar Municipal permission will be within your responsibility. Any additional permission required that will be within your scope.</p>	<p>Conditions of bidding document shall prevail</p>
<p>68.</p>	<p>PKG 0153- Equipment for Setting up of IT infrastructure for Precision Engineering at WSC</p>	<p>Section 4</p>	<p>Bidding Forms Manufacturer’s Authorization</p>	<p>Many of the standard products make it difficult to get a manufacturer authorization letter. We will give you with a standard OEM product and offer a warranty. Please help us with</p>	<p>Conditions of bidding document shall prevail</p>

ANNEXURE – III

ADDENDUM -01

PKG 0154- Training Equipment & Tools for setting up COE in Smart Manufacturing at WSC					
69.	PKG 0154- Training Equipment & Tools for setting up COE in Smart Manufacturing at WSC	Section 6 Page 6-5: A2: Industry 4.0	List of Goods and Related Services and Technical Specifications: The Industry 4.0 should be an inter disciplinary focused on developing skill excellence in the field of Design, Digitalization and Industry 4.0 and should meet the demands of the industries’ ever-changing processes. 	Each OEM/Manufacturers will have their own design for Industry 4.0 applications. We request for a generalised specifications for the same.	The bidder should provide the setup with minimum specifications as mentioned in the Bidding document.
70.	PKG 0154- Training Equipment & Tools for setting up COE in Smart Manufacturing at WSC	Section 6 Page 6-5: A2: Industry 4.0	List of Goods and Related Services and Technical Specifications: Note: The specification of above-mentioned equipment are indicative	As mentioned above, the design will be OEM/Manufacturer specific. We therefore request to remove the point	The bidder should provide the setup with minimum specifications as mentioned in the bidding document.

ANNEXURE – III

ADDENDUM -01

			<p>only. OEMs/Resellers may suggest better equipment with latest specifications and futuristic technology.</p> <p>..</p>		
71.	<p>PKG 0154- Training Equipment & Tools for setting up COE in Smart Manufacturing at WSC</p>	<p>Section 6 Page 6-5:: A2: Industry 4.0</p>	<p>List of Goods and Related Services and Technical Specifications</p> <p>§ Possibility of registering the sensors on the Schneider Electric server (Tele Mecanique Cloud Infrastructure) to configure alarms.</p> <p>..</p> <p>..</p> <p>Wiring of the internal and external network connections.</p>	<p>Mentioned point is too specific. Kindly change it as "To be stored on local cloud server".</p>	<p>Accepted.</p> <p>The point is modified and to be read as follows: Section 6: List of Goods and Related Services and Technical Specifications Sl. No. 2: Industry 4.0: The Industry 4.0 should be an inter..</p> <p>..</p> <p>Possibility of registering the sensors on the local cloud server</p> <p>..</p> <p>Wiring of the internal and external network connections.</p>

ANNEXURE – III

ADDENDUM -01

PKG 0155- Furniture for Precision Engineering Labs					
72.	PKG 0155- Furniture for Precision Engineering Labs	Bidding Document	Single-Stage: Two-Envelope Bidding Procedure		Earlier NCB document was posted for Package no 0155. Since this package is a shopping package; therefore entire bid document is replaced with new RFQ. Bidders are requested to submit the bid as per RFQ which is attached as Appendix H of this Addendum

Annexure-IV

Screenshot of Participants of the Virtual Pre-Bid Meeting

The screenshot displays a Microsoft Teams virtual meeting interface. At the top, the meeting title is "PRE-BID MEETING DATED 30.03.2024 FOR PHASE 8 PROCUREME...". The interface includes a top navigation bar with icons for Chat, People (28), Raise, React, View, Apps, and More. On the right side, there are controls for Camera, Mic, Share, and a red "Leave" button. The main area is divided into a grid of participant video thumbnails and a central contact list. The chat window on the right shows a message from R.ugesh (FESTO India Pvt Ltd) and a reply from PARESH MODH (Unverified) asking about a package. The Windows taskbar at the bottom shows the date as 30-03-2024 and the time as 11:35.

Participants:

- Chandan Kumar
- Niranjan (Unverified)
- Brad Ker (Labtech) ...
- R.ugesh (FESTO) (U...
- VentureEmco (Unv...
- Deepak Mehrotra (Unv...
- Jagan Antharam (E...
- PARESH MODH (U...
- Sapna (Guest) (Unv...
- Padma Lifestyle (U...
- ajay (Unverified)
- CA & S Solutions P...
- Rajesh Sharma (Un...
- D N Swain (Unverif...
- Srikanta Patra
- K Ananth (Unverifi...
- Swaraj Mishra (Ext...
- Amarnath Durgale ...

Chat Window:







- Meeting chat
- R.ugesh (FESTO India Pvt Ltd) 11:32: r.ugesh@festo.com, +91 9911167313,package:154
- VentureEmc... 30-03-2024 11:30: Sunil sharma Venture Enterprises. 9833608283....
- which package?
- PARESH MODH (Unverified) 11:32: pamtrons parash modh mumbai PKG 0146 Healthcare assistance training facility

System Information:

- Temperature: 33°
- Date: 30-03-2024
- Time: 11:35







Appendix A

Revised Section 6 for package 0143

Sr. No.	Item No.	Name of Goods or Related Services (Modified)	Description (Modified)	Quantity (Modified)	UoM (Modified)
			PKG 0143: Training Equipment, Tools & Furniture for setting up of Food & Beverage Operations facility at WSC		
1	A1	Western Cutlery Set	Each set will have:  Spoon Table L21cm  Fork Table L21cm  Knife Table L23cm  Spoon Dessert L19.4cm  Fork Dessert L19.4cm  Knife Dessert L20cm	100	Sets



Appendix A

Revised Section 6 for package 0143

			 <p style="text-align: center;">Tulip Design</p> <p>Fork Fish L18cm</p>  <p style="text-align: center;">Tulip Design</p> <p>Knife Fish L20.7cm</p>  <p style="text-align: center;">Tulip Design</p> <p>Spoon Tea L13.5cm</p>  <p style="text-align: center;">Tulip Design</p> <p>Spoon Soup L17.8cm</p>  <p style="text-align: center;">Tulip Design</p> <p>Knife Butter L18.2cm</p>  <p style="text-align: center;">Tulip Design</p> <p>Knife Steak L22cm</p> <p>All material should be: Stainless steel, Thickness/ Gauge: 18/10 stainless steel with a high-polish finish, food grade, non-toxic, anti-rust, dish washer safe.</p> <p>Similar or close to size</p> <p>The overall appearance of the product shall be as per photograph. The product should be of reputed brand.</p> <p>SS SAFICO, Churchill, Borosil Shri & Sam or Equivalent</p>		
--	--	--	---	--	--



Appendix A

Revised Section 6 for package 0143

2	A2	Demi-tasse spoon	 <p>Espresso Spoon - smaller than teaspoon – L 10.8cm</p> <p>Material should be: Stainless steel, Thickness/ Gauge: 18/10 stainless steel with a high-polish finish, food grade, non-toxic, anti-rust, dish washer safe.</p> <p>Similar or close to size.</p> <p>The overall appearance of the product shall be as per photograph. The product should be of reputed brand.</p> <p>SS WMF, Churchill, Borosil Shri & Sam or Equivalent</p>	20	Pcs
3	A3	Service equipment S/S	 <p>Pic. 1</p>  <p>Pic. 2</p> <p>Pic. 1 - For bread service Tong S/S- 17.5cm, Material: 304 stainless steel, non-toxic, anti-rust, dish washer safe.</p>	20	Set



Appendix A

Revised Section 6 for package 0143

			<p>Pic. 2 - Bread-basket material - rattan/wicker. Colour: Brown Dimension: L 28-inch x W 12-inch x H 3.5 inch minimum</p> <p>Each set contains: one tong and a bread-basket.</p> <p>Both items should be similar or close to the size.</p> <p>The overall appearance of the product shall be as per photograph. The product should be of reputed brand.</p>		
4	A4	Main Course plate (31 cm)	 <p>Dimension: 31 cm Dia, Similar or close to size. Material: Porcelain and should be dish washer safe. Thickness: 6 mm, Similar or close to that. Colour: Ivory white</p> <p>The overall appearance of the product shall be as per photograph. The product should be of reputed. brand.CHURCHILL, Borosil or Equivalent</p>	100	Pcs
5	A5	Chinaware (plates)	 <p>One set contains: One no. Plate Round Swirl 17cm Dia One no. Plate Round Swirl 25cm Dia One no. Plate Round Swirl 32cm Dia</p>	60	Sets



Appendix A

Revised Section 6 for package 0143

			<p>One no. Bowl Round Swirl 24cm Dia</p> <p>All items are similar or close to size</p> <p>Material should be: Porcelain, dish washer safe. Thickness: 6 mm or similar thickness.</p> <p>The overall appearance of the product shall be as per photograph. The product should be of reputed brand. As per hotel standard.</p> <p>CHURCHILL, Borosil or Equivalent</p>		
6	A6	Side plate	 <p>Material: Porcelain, dish washer safe. Colour: Ivory white Size: 8 inches Dia, similar or close to the size. Thickness: 4 mm minimum or similar thickness.</p> <p>The product should be of reputed brand. CHURCHILL, Borosil or Equivalent</p>	150	Pcs
7	A7	Show plates	 <p>Dimension – Dia 305 x H 10mm, similar or close to size.</p>	60	Pcs



Appendix A

Revised Section 6 for package 0143

			<p>Material: Porcelain, earthenware, stoneware. Any one is fine. Dish washer safe. Colour: Ivory white.</p> <p>The overall appearance of the product shall be as per photograph. The product should be of reputed brand.</p> <p>CHURCHILL, Borosil or Equivalent</p>		
8	A8	Toothpick holders	 <p>Dimensions: H 3 inches x Dia (inner) 2 inches minimum, similar or close to size. Material: Stainless Steel polished, food grade, non-toxic, anti-rust, dish washer safe. Colour: Silver Finish: Polished Capacity: must hold 500 toothpicks approx.</p> <p>The overall appearance of the product shall be as per photograph. The product should be of reputed brand.</p>	20	Pcs
9	A9	Finger bowls	 <p>Colour: White Material: Bone chine/ceramic/porcelain or equivalent, dish washer safe. Capacity 250 ml, Similar or close to capacity. Thickness: 2mm minimum or similar to this thickness.</p>	30	Pcs



Appendix A

Revised Section 6 for package 0143

			<p>The overall appearance of the product shall be as per photograph. The product should be of reputed brand. CHURCHILL, Borosil or Equivalent</p>		
10	A10	Soup set	 <p>Each set contains: One Bowl Soup: Dia 4 inch One Saucer: Dia 6 inch (comes in a set). Similar or close to size. Material: Porcelain/ ceramic, dish washer safe. Thickness: 5mm approx. Colour: White</p> <p>The overall appearance of the product shall be as per photograph. The product should be of reputed brand. CEREBON, Borosil or Equivalent</p>	80	Sets
11	A11	Cereal bowl	 <p>Cereal Bowls each 6 Inch Dia Material: Ceramic or bone china, dish washer and Microwave Safe Colour: Premium White Capacity: 400-500 ml Thickness: 4mm minimum, similar or close to the thickness.</p>	40	Pcs



Appendix A

Revised Section 6 for package 0143

			<p>The overall appearance of the product shall be as per photograph. The product should be of reputed brand. CHURCHILL, Borosil or Equivalent</p>			
12	A12	Packet holder	sugar	 <p>Bowl Sugar Open Dia 8 cm x H 3 inches, similar or close to the size. Material: Bone china/ porcelain, dish washer safe.</p> <p>Thickness: 3 mm, similar or close to the thickness.</p> <p>The overall appearance of the product shall be as per photograph. The product should be of reputed brand.</p> <p>CHURCHILL, Borosil or equivalent.</p>	30	Pcs
13	A13	Cutlery Compartment Holder	Box	 <p>To keep cutleries Good quality materials: Moulded plastic or equivalent. Durable plastic should be sturdy and crack-resistant for longevity.</p> <p>Cutlery Tray 4-compartments</p> <p>4-compartment design enables the efficient organization of cutlery pieces.</p> <p>Easy-to-grip handle provides a comfortable and secure grip for users</p> <p>Dimensions: - L 517 x W 285 x H 95 mm, similar or close to size.</p> <p>Colour – Grey or Black.</p>	12	Pcs

Appendix A

Revised Section 6 for package 0143

			The overall appearance of the product shall be as per photograph. The product should be of reputed brand.		
14	A14	Hot Water Urn S/S	 <p>Material: Food grade 304 Stainless Steel, food grade, non-toxic, anti-rust, dish washer safe, double insulated. Use: To dispense hot water. Similar to Kettle but larger capacity. Should have a tap to dispense the water. With a Handle: Heat proof. Capacity: 20 L, Similar or close to size.</p> <p>The overall appearance of the product shall be as per photograph. The product should be of reputed brand.</p>	1	Pc
15	A15	Cloth Drying Rack		3	Pcs

Appendix A

Revised Section 6 for package 0143

			<p>Material should be: Steel, Polyester powder coating, anti-rust.</p> <p>Dimensions: L 173 cm x W 57 cm x H 103 cm, Similar or close to size.</p> <p>No. of rows: 12 minimum</p> <p>Use: To dry the wet clothes for bar, coffee and restaurant.</p> <p>Foldable</p> <p>The overall appearance of the product shall be as per photograph. The product should be of reputed brand.</p>		
16	A16	Center piece	 <p>Material: Ceramic or glass.</p> <p>Dimension: H 13 cm, similar or close to this size.</p> <p>Use: To place on the table with flower</p> <p>The overall appearance of the product shall be as per photograph. The product should be of reputed brand.</p>	25	Pcs

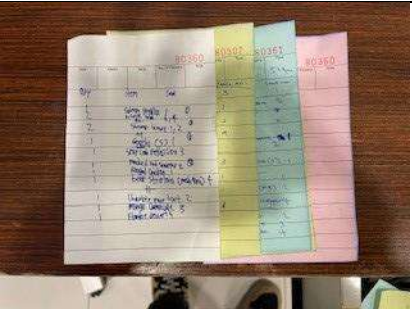

Appendix A

Revised Section 6 for package 0143

17	A17	Cruet Set	 <p>Dimension: H 12 cm x Dia 5.8 cm (Minimum), Similar or close to size. Material: Stainless steel, rust free top + Cherry Wood Use: Salt and Pepper holders. Salt and Pepper Mill.</p> <p>The overall appearance of the product shall be as per photograph. The product should be of reputed brand. Good quality as per hotel standard.</p>	25	Pcs
18	A18	Order Chit (4 Ply)	 <p>Note pad with 4 ply carbon copy with 4 different colours. As per picture. Each packet contains: Minimum 50 pages of 4 ply carbon copy. Dimensions: L 5.5 inches x W 4 inches, Similar or close to size. Material: Good quality paper.</p> <p>The overall appearance of the product shall be as per photograph. The product should be of reputed brand.</p>	100	Pkts
19	A19	Demi-tasse set		20	Sets

Appendix A

Revised Section 6 for package 0143

			 <p>ESPRESSO CUP and Saucer Each set contains: One Cup and one saucer (Should fit the cup). Colour: White Capacity: Cup: 70 ml Dimensions: Cup: H 4.8 cm x W 6.8 cm Saucer: Dia 11.6 cm Similar or close to size. Material: Porcelain, dish washer safe.</p> <p>The overall appearance of the product shall be as per photograph. The product should be of reputed brand. CHURCHILL, Borosil or equivalent.</p>		
20	A20	Sauce boat	  <p>Gravy Boat with Saucer:</p>	6	Sets



Appendix A

Revised Section 6 for package 0143

			<p>Each set contains: One boat and one saucer (Should fit the boat). Material Porcelain, dish washer safe. Colour White Capacity Boat: 454 g; Saucer: should fit the boat. Similar or close to size. Use: Fine high-quality Porcelain Sauce & Salad Dressing Boat Colour: White Special Feature Durability, Sturdy. With its narrow, dripless spout, easily pour sauces without mess or use a ladle to serve sauces. The comfortable ergonomic handle is easy to grip yet sturdy enough to hold up to 16oz of sauce. Fired at a high temperature to ensure durability, can warm sauce in the microwave oven and then toss it directly in the dishwasher.</p> <p>The overall appearance of the product shall be as per photograph. The product should be of reputed brand. CHURCHILL, Borosil or equivalent.</p>		
21	A21	Egg cup w stand	 <p>Material: porcelain, dish washer safe. Dimensions: H 7 cm x W 5 cm, similar or close to size. Shapes: as per picture. Colour: Ivory white</p> <p>The overall appearance of the product shall be as per photograph. The product should be of reputed brand.</p>	6	Pcs



Appendix A

Revised Section 6 for package 0143

			CHURCHILL, Borosil or equivalent.		
22	A22	Pasta dish	 <p>Dimension: 24 cm Dia- Plate has a slight in-depth (Depth: 1.75 inches), similar or close to size. Material: Porcelain, dish washer safe. Colour: White</p> <p>The overall appearance of the product shall be as per photograph. The product should be of reputed brand. CHURCHILL, Borosil or equivalent.</p>	40	Pcs
23	A23	Creamer jug	 <p>Creamer Jug H 7 x Dia 6 cm, similar or close to size. Colour: White Material: Porcelain, dish washer safe.</p> <p>The overall appearance of the product shall be as per photograph. The product should be of reputed brand. CHURCHILL, Borosil or equivalent.</p>	12	Pcs



Appendix A

Revised Section 6 for package 0143

24	A24	Platter service equipment	 <p>If Oval in shape: Largest size is approx. L 20 x W 34 cm, similar or close to size. If round, different sizes like: Each set will have: One Large: Dia 16 inches, One medium: Dia 14 inches and One small: Dia 12 inches</p> <p>Material should be: 304 Stainless steel, food grade, non-toxic, anti-rust, dish washer safe.</p> <p>The overall appearance of the product shall be as per photograph. The product should be of reputed brand. SS SAFICO, Shri & Sam or Equivalent</p>	12	Sets
25	A25	Service trolley	 <p>Three tiers: Solid trays. With handle at both sides. Material: Mild steel, anti-rust, Powder coated. Colour: Steel or steel grey. Sides with elevated boundaries 2 inches approx. These shelves may be adjustable or removable to provide flexibility in organising items of different sizes (Preferable). Trolley must have raised edges or railings (2 inches approx.) on the shelves to prevent items from sliding off during movement.</p>	2	Pc



Appendix A

Revised Section 6 for package 0143

			<p>Wheel with lock system, noise free, sturdy. Dimension: L 75 cm x W 45 cm x H 90 cm, similar or close to size.</p> <p>The overall appearance of the product shall be as per photograph. The product should be of reputed brand. As per hotel standard.</p>		
26	A26	Wine decanter	 <p>Dimension: Height 22.4 cm, Diameter: 22.4cm, similar or close to size. Capacity: 1000ml (Suitable for 1 regular size wine bottle) Material: Glass, transparent and dish washer safe.</p> <p>The overall appearance of the product shall be as per photograph. The product should be of reputed brand. As per hotel standard. Borosil, WSJ or Equivalent</p>	2	Pcs
27	A27	Classical wine glasses	 <p>Dimension: Width: 71 mm, Height: 161 mm Capacity: 230ml Similar or close to size. Material: Glass, transparent and dish washer safe.</p> <p>The overall appearance of the product shall be as per photograph. The product should be of reputed brand. As per hotel standard. OCEAN, Borosil or Equivalent</p>	30	Pcs



Appendix A

Revised Section 6 for package 0143

28	A28	High ball juices glasses	 <p>Tumbler Hi Ball Dimension: Ø 60 x H 165mm Capacity: 320ml Similar or close to size. Material: Glass, transparent and dish washer safe.</p> <p>The overall appearance of the product shall be as per photograph. The product should be of reputed brand. As per hotel standard. OCEAN, Borosil or Equivalent.</p>	80	Pcs
29	A29	Rock glasses	 <p>Glass Rock Capacity: 30cl Dimension: Ø 7.5 x H 9 cm Similar or close to size. Material: Glass, transparent and dish washer safe.</p> <p>The overall appearance of the product shall be as per photograph. The product should be of reputed brand. As per hotel standard. OCEAN, Borosil or Equivalent.</p>	20	Pcs



Appendix A

Revised Section 6 for package 0143

30	A30	Pilsner glasses	 <p>Dimension: Ø 8 x 24 cm Similar or close to size. Material: Glass, transparent and dish washer safe.</p> <p>The overall appearance of the product shall be as per photograph. The product should be of reputed brand. As per hotel standard. OCEAN, Borosil or Equivalent</p>	20	Pcs
31	A31	Martini glasses	 <p>Glass Martini with Stem Capacity: 21cl ARC. Similar or close to size. Material: Glass, transparent and dish washer safe.</p> <p>The overall appearance of the product shall be as per photograph. The product should be of reputed brand. As per hotel standard. OCEAN Borosil or Equivalent</p>	10	Pcs



Appendix A

Revised Section 6 for package 0143

32	A32	Sherry/ port	 <p>Dimension: H 151 x W 66 MM Capacity: 21.3CL Similar or close to size. Material: Glass, transparent and dish washer safe.</p> <p>The overall appearance of the product shall be as per photograph. The product should be of reputed brand. As per hotel standard. OCEAN, Borosil or Equivalent</p>	6	Pcs
33	A33	Brandy snifter	 <p>CLASSIC – BRANDY Capacity: 34 CL Similar or close to size. Material: Glass, transparent and dish washer safe.</p> <p>The overall appearance of the product shall be as per photograph. The product should be of reputed brand. As per hotel standard. OCEAN, Borosil, or Equivalent.</p>	6	Pcs



Appendix A

Revised Section 6 for package 0143

34	A34	Multi-purpose wine glass	 <p>Capacity: 400 ml Similar or close to size. Material: Glass, transparent and dish washer safe. Use: SODUKU or equivalent, Italian Premium Wine Glass for Multi-Purpose USE of RED & White Wine.</p> <p>The overall appearance of the product shall be as per photograph. The product should be of reputed brand. As per hotel standard. OCEAN, Borosil, or Equivalent</p>	60	Pcs
35	A35	Champagne glasses	 <p>Glass Champagne Flute Glasses Dimension: Given in picture.</p>	60	Pcs



Appendix A

Revised Section 6 for package 0143

			<p>Capacity: 160 ml Similar or close to size. Material: Glass, transparent and dish washer safe.</p> <p>The overall appearance of the product shall be as per photograph. The product should be of reputed brand. As per hotel standard. OCEAN, Borosil, or Equivalent.</p>		
36	A36	Shooter glasses	 <p>Capacity: 50ml Similar or close to size. Material: Glass, transparent and dish washer safe.</p> <p>The overall appearance of the product shall be as per photograph. The product should be of reputed brand. As per hotel standard. OCEAN, Borosil, or Equivalent.</p>	6	Pcs
37	A37	Margarita coupe	 <p>Similar design is fine. Capacity: 330 ml Similar or close to size. Material: Glass, transparent and dish washer safe.</p> <p>The overall appearance of the product shall be as per photograph. The product should be of reputed brand. As per hotel standard. OCEAN, Borosil, or Equivalent.</p>	20	Pcs



Appendix A

Revised Section 6 for package 0143

38	A38	Water Goblet	 <p>Glass Goblet Capacity: 33 cl ARC Similar or close to size. Material: Glass, transparent and dish washer safe.</p> <p>The overall appearance of the product shall be as per photograph. The product should be of reputed brand. As per hotel standard. OCEAN, Borosil, or Equivalent.</p>	100	Pcs
39	A39	Water pitcher	 <p>Capacity: 1.9 L Similar or close to size. Design: With half cover with steel handle. Material should be: 304 Stainless steel or cromargan, food grade, non-toxic, anti-rust, dish washer safe.</p> <p>The overall appearance of the product shall be as per photograph. The product should be of reputed brand. As per hotel standard. SS SAFICO, Shri & Sam or Equivalent</p>	6	Pcs



Appendix A

Revised Section 6 for package 0143

40	A40	Wine service equipment	<p>Each set contains: One basket and one wine trolley.</p>  <ol style="list-style-type: none"> 1. Basket Wine Silverplated Dimension: measures approx. L 24 cm x W 11 cm x H 13 cm. Similar or close to size. weighs approx. 378 grams. Colour: Silver Can carry weight of at least 5 kg.  <ol style="list-style-type: none"> 2. Trolley Wine - Tier Round W Ø 500 x H 900 mm minimum. Can carry 120 kg weight minimum. Similar or close to size. Mobile wheel: 4 universal wheels and 2 universal wheels with brake are installed at the bottom, which is convenient, fast and safe to move, saving effort. Armrest design: humanized design, lever principle saves effort and should be more convenient, safe. Rugged bracket: It is made of metal, and the 3-layer design is better for storing more items. It has strong load-bearing capacity and truly liberates hands. Safety guardrail design: Heighten the safety guardrail and deepen the design to realize the safety of the items and stack them. Matte panel: The upper and lower three-layer wooden board is clear, natural. The surface of the wooden board is specially treated, polished and polished to produce a refined effect, and the protective bar is added to ensure safety. <p>The overall appearance of the products shall be as per photograph. The products should be of reputed brand. As per hotel standard.</p>	3	Sets
----	-----	------------------------	---	---	------



Appendix A

Revised Section 6 for package 0143

41		Wine carafe	 <p>Wine carafe Material: Glass, transparent and dish washer safe. Capacity: 0.5 L minimum Height: 5-1/4" Top Diameter: 2-1/4" Bottom Diameter: 2-1/4" Max Diameter: 3-1/8" Similar or close to size.</p> <p>The overall appearance of the product shall be as per photograph. The products should be of reputed brand. As per hotel standard. OCEAN, Borosil, or Equivalent.</p>		10 pcs
42		Wine bottle opener	 <p>Wine bottle opener. Dimension: The size of this wine corkscrew after folding is 4.69 inches * 1.1 inches. Similar or close to size. Materia: Sturdy Stainless Steel with wooden handle. Finish Type: Steel polished Item Weight: 90 Grams approx. Materials: The wine opener is made of food-grade stainless steel with a handle inlaid with natural wood. Product include: The bottle opener fold up is an all-in-one type, includes multiple functions. It can open wine corks, beer lids, and can also be used to cut foil.</p> <p>The overall appearance of the product shall be as per photograph. The products should be of reputed brand. As per hotel standard.</p>		40 pcs

Appendix A

Revised Section 6 for package 0143

43	A41	Punch bowl	 <p>Bowl Punch/Salad Dimension: H 19 cm x Dia 23 cm Foot dimension: 16" Round Footed Stainless steel. Capacity: 13 Liter approx. Similar or close to size. Material (Both body and foot): 304 Stainless steel, food grade, non-toxic, anti-rust, dish washer safe.</p> <p>The overall appearance of the product shall be as per photograph. The products should be of reputed brand. As per hotel standard.</p>	1	Pc
44	A42	Bartender set	 <p>Each set contains: 14-Pieces minimum:</p> <p>Cocktail rustproof Shaker SS with Mixing Glass 24oz 30/60ml Stainless Steel Cocktail Jigger and 15/30ml Stainless steel jigger (2 x Double-sided Jigger) Strainer SS (Hawthorne strainer) Mixer Spoon SS Tongs SS Pourer SS (2 x Liquor Pourers) Muddler (Mojito Muddler)</p>	20	Sets



Appendix A

Revised Section 6 for package 0143

			<p>Double lever corkscrew Stoppers (2 x Stoppers) Bottle Opener With a Acryli wood stand or equivalent Material: 304 Stainless Steel Use: Bar, Hotel, Family</p> <p>This shaker set should made up of food-grade 304 stainless steel and is completely safe to use. Heavy-duty and high-grade martini shaker cocktail set. This entire bar accessories kit should made up of stainless-steel alloy SS304. It must be all dishwasher compatible.</p> <p>The overall appearance of the product shall be as per photograph. The products should be of reputed brand. As per hotel standard.</p>		
45	A43	Garnish compartment	 <p>6 Compartment Garnish Condiment Tray: Each set contains: 6 removable compartments and a box with transparent lid. Dimension: Box: L 19.5 inches x W 6 inches x H 3.5 inches Compartment: L 5.5 inches x W 2.9 inches x H 2.7 inches. Similar or close to size. Material: Food grade plastic, non-toxic, transparent cover box With six removable compartments made up of food grade durable plastic. Dish washer safe.</p> <p>Colour: Black box, transparent lid with white compartments or equivalent.</p>	4	Set



Appendix A

Revised Section 6 for package 0143

			The overall appearance of the product shall be as per photograph. The products should be of reputed brand. As per hotel standard.		
46	A44	Cocktail clips	 <p>Cocktail clips or also known as cocktail picks.</p> <p>Each packet must contain 50 pieces minimum.</p> <p>Dimension: Minimum L 12 cm</p> <p>Similar or close to size.</p> <p>Material: Wooden/Bamboo. Must be food grade and non-toxic.</p> <p>Use: To hold the garnish on the glass.</p> <p>The overall appearance of the product shall be as per photograph. The products should be of reputed brand. As per hotel standard.</p>	50	Packs
47	A45	Bar caddy six compartment unit	 <p>Bar Caddy Organizer with 6 Compartments, Bar Condiment Caddy Organizer with Compartment of Napkin Holder & Straw Holder.</p> <p>Each piece is with six compartments made up of food grade plastic.</p>	4	Pcs.



Appendix A

Revised Section 6 for package 0143

			<p>Dimension: L 9" x W 5 ¼" x H 4 ¼". Similar or close to size. Material: Durable plastic, food grade plastic, non-toxic. Colour: Black</p> <p>The overall appearance of the product shall be as per photograph. The products should be of reputed brand. As per hotel standard.</p>		
48	A46	Bar service flexi-mat	 <p>Pic- 1</p>  <p>Pic- 2</p> <p>Each set contains: 2 Sizes - 1 Pcs each size First picture - Mat Service Bl W 12 x L18 inches Thickness: 1.5 cm 2nd picture - Mat Bar Bl L 60 x W 8 cm Thickness: 1.8 cm Similar or close to size. Material: Rubber Colour: Black</p> <p>The overall appearance of the product shall be as per photograph. The products should be of reputed brand. As per-hotel standard.</p>	12	Sets



Appendix A

Revised Section 6 for package 0143

49	A47	Ice scoop	 <p>Polished Stainless Steel Ice Scoop: Dimensions – W 80mm x L 220mm x H 55mm Capacity – 12oz Similar or close to size. Material: 304 Stainless steel, food grade, non-toxic, anti-rust, dish washer safe. With steel handle.</p> <p>The overall appearance of the product shall be as per photograph. The products should be of reputed brand. As per hotel standard. SS SAFICO, Shri & Sam, or Equivalent IS</p>	10	Pc
50	A48	Waiter tray	 <p>Tray Round Brown: Dimension: 14" Dia, similar or close to size. Material: Food grade durable hard wearing melamine, ensuring a durable finish to resist wear and tear, unbreakable, non-toxic, dish washer safe. Nonslip tray. Colour: Dark brown/ Black</p> <p>The overall appearance of the product shall be as per photograph. Product should be of reputed brand. As per hotel standard.</p>	40	Pcs
51	A49	Runner tray	 <p>Tray Rectangular Brown:</p>	20	Pcs



Appendix A

Revised Section 6 for package 0143

			<p>Dimension: L 65 x W 45 cm, similar or close to size. Material: Food grade durable hard wearing melamine, ensuring a durable finish to resist wear and tear, unbreakable, non-toxic, dish washer safe. Nonslip tray. Colour: Dark brown/Black</p> <p>The overall appearance of the product shall be as per photograph. Product should be of reputed brand. As per hotel standard.</p>		
52	A50	Bottle Holder (Speed Rack)	<div style="display: flex; justify-content: space-around; align-items: center;">   </div> <p style="text-align: center;">Pic 2</p> <p>Pic 1 Bottle Holder (Speed Rack): Material: 304 stainless-steel metal rack to hold bottles. Dimensions: H 90 x L 560 x W 100 mm. Thickness: Minimum 1 mm. Similar or close to size. Colour: Steel finish (Matt) Can be hooked on to the cupboard like 1st picture or screwed to the bar counter below shelve like 2nd picture.</p> <p>The overall appearance of the product shall be as per photograph. Product should be of reputed brand. As per hotel standard.</p>	4	Pcs
53	A51	Bar Cloth	 <p>Dimension: L 12" x W 12", Similar or close to size.</p>	20	Pcs



Appendix A

Revised Section 6 for package 0143

			<p>Material - Microfiber cloth, cotton.</p> <p>Colour: Various Colours.</p> <p>The overall appearance of the product shall be as per photograph. Product should be of reputed brand. As per hotel standard.</p>		
54	A52	Cleaning cloth	 <p>Dimension: L 40 cm x W 40 cm, Similar or close to size.</p> <p>Material - Microfiber cloth, cotton.</p> <p>Colour: Various Colours.</p> <p>Use: All purpose Microfibre cleaning cloths for Home, Kitchen.</p> <p>The overall appearance of the product shall be as per photograph. Product should be of reputed brand. As per hotel standard.</p>	20	Pcs
55	A53	Rubber floor mat	 <p>Top Floor Rubber Mat:</p> <p>Dimension: W 90cm x L 150 cm Approx. Similar or close to size.</p> <p>Material: Active scraper durable anti-slip rubber mat.</p> <p>Colour: Black</p>	4	Pcs



Appendix A

Revised Section 6 for package 0143

			<p>Use: For bar area use.</p> <p>The overall appearance of the product shall be as per photograph. Product should be of reputed brand. As per hotel standard.</p>		
56	A54	Cutting Board (Garnish)	 <p>Acrylic Cutting Chopping Board: Dimension: L 15 inches x W 10 inches, similar or close to size. Material: Acrylic, food grade and non-toxic, dishwasher safe Colour: White</p> <p>The overall appearance of the product shall be as per photograph. Product should be of reputed brand. As per hotel standard.</p>	8	Pcs
57	A55	Knife (Garnish)	 <p>Each set contains: 4 different pieces in one set (Refer picture) Dimension: Blade length 6.3 Inches average, Item Length 16 Centimetres average. Similar or close to size. Material: High carbon 304 stainless steel blade with durable triple-rivet wooden handle. Dishwasher safe, food grade and non-toxic, anti-rust. Colour: Steel blade and wooden handle</p> <p>The overall appearance of the product shall be as per photograph. Product should be of reputed brand. As per hotel standard.</p>	8	Sets

Appendix A

Revised Section 6 for package 0143

58	A56	Wine Bucket S/S	 <p>Dimension: Opening Diameter : 20 x 20 Centimetres, Height : 22 Centimetres. Similar or close to size. Material: Hammered 304 stainless steel, food grade, non-toxic, anti-rust, dish washer safe. Colour: Steel finish.</p> <p>Bucket must have comfortable holder at both sides, of same material.</p> <p>The overall appearance of the product shall be as per photograph. Product should be of reputed brand. As per hotel standard.</p>	10	Pcs
59	A57	Wine Bucket Stand S/S	 <p>Bucket stand: Foldable. Dimension: Overall Height : 70 Centimeters / 27.50 Inches (Approx). Similar or close to size. Material: 304 Stainless steel, food grade, non-toxic, anti-rust, dish washer safe. Colour: Steel finish.</p> <p>Must be stable when bucket is placed on it with 20 kg weight minimum.</p>	10	Pcs

Appendix A

Revised Section 6 for package 0143

			The overall appearance of the product shall be as per photograph. Product should be of reputed brand. As per hotel standard.		
60	A58	Espresso Machine + All Tools	 <p>Shaker Flour for Cocoa Powder For espresso machine do seek what is the hotels, cafes or restaurants using that is popular in Odisha and must seek supplier to provide the following: (Similar or close to size) Each set contains: Minimum</p> <p>Espresso Machine with dual head portafilter units Coffee grinder Tamper H8cm Silver Base Ø5.5cm Box Knock Basic 6" x 5.5" x 4". Mat Tamping Corner CAFELAT Thermometer Milk Compact Designer Glass Shot for espresso with white line 1.5oz Ø5H6cm. Shaker Flour/Sugar w fine mesh Timer Digital L8 x W6 x H2cm Coffee measuring scale 5kg 140x235x13mm ADE KE850 Cleaning Powder Cleaning Brush Blind Basket</p> <p>Espresso Machine with dual head portafilter units:</p>	4	Sets

Appendix A

Revised Section 6 for package 0143

			<p>ELECTRICAL SUPPLY: 380-415 V3N 50-60 Hz</p> <p style="padding-left: 40px;">220-240 V3 50-60 Hz</p> <p style="padding-left: 40px;">220-240 V 50-60 Hz</p> <p>INSTALLED POWER: 7,2-8,6 kW</p> <p>DIMENSIONS: L 768 mm, H 531 mm, D 592 mm</p> <p>Similar or close to the size.</p> <p>IGNITION TIME: Only 6 minutes maximum.</p> <p>NET WEIGHT 65 Kg</p> <p>OPTIONAL: Turbosteam milk4, Tall Cups Kit</p> <p>Heat exchanger system:</p> <p>Not different temperatures for each coffee group, but an innovative and sustainable centralized heating that ensures:</p> <ul style="list-style-type: none"> • high repeatability of dispensing temperature. • the possibility to dispense at lower temperatures without affecting the effectiveness of other services - steam and hot water. • immediate selection of temperature, on the display, based on the chosen blend/single origin. <p>Hot water only where and when needed: coffee boiler and service boiler must be separate. A single coffee boiler connects to the coffee groups,</p> <p>Must always maintain at the correct service temperature. This way, energy and water consumption should be reduced, while the flexibility of using the various groups increase, keeping dispensing constant.</p>		
--	--	--	--	--	--



Appendix A

Revised Section 6 for package 0143

		<p>Minimize thermal losses: thanks to the compact size of both the coffee boiler (1.1L) and the service boiler (3.9L), as well as their effective insulation</p> <p>All basic adjustments, essential for achieving the best cup results, can be made without the need for technical intervention.</p> <p>The machine must communicate automatically with the grinder-doser, recognizing the portafilter and identifying only one correct recipe at a time, thus preventing errors.</p> <p>Coffee grinder:</p> <p>Dimensions (wxdxh) (mm): 210 x 384 x 559</p> <p>Electrical power (W): 550 W</p> <p>Grinding capacity (G/S): 3</p> <p>Compartment capacity (G): 1100</p> <p>Grinding disc diameter (mm): 64</p> <p>Blade material: Titanium-coated stainless steel (4 times more durable than standard blenders)</p> <p>Touch screen.</p> <p>Weight (kg): 13</p> <p>Technology that automatically makes any necessary grinding and dosing corrections to ensure precise and consistent dispensing without any direct intervention from the counter.</p> <p>It should come with all accessories.</p> <p>Precision grinding so the coffee must grind straight into the filter holder, leaving no stray particles. The dispensing process should be accompanied by an illuminating light, ensuring a well-lit and clear working area.</p>		
--	--	---	--	--

Appendix A

Revised Section 6 for package 0143

			<p>With adjust preferences each time or set them once and for all. Few simple taps on the intuitive display, one can easily configure the grind size and time.</p> <p>The overall appearance of the product shall be as per photograph. Product should be of reputed brand. As per hotel standard.</p>		
61			<p>12 Ounce Frothing Pitcher</p>  <p>Milk frothing pitcher with cover. Capacity: 12oz Similar or close to size. Material: 304 Stainless Steel Colour: Finished steel With comfortable handle.</p> <p>The overall appearance of the product shall be as per photograph. Product should be of reputed brand. As per hotel standard.</p>	10	Pcs
62			<p>20 Ounce Frothing Pitcher</p>  <p>Milk frothing pitcher with cover. Capacity: 20 oz Similar or close to size. Material: 304 Stainless Steel Colour: Finished steel With comfortable handle.</p> <p>The overall appearance of the product shall be as per photograph. Product should be of reputed brand. As per hotel standard.</p>	10	Pcs

Appendix A

Revised Section 6 for package 0143

63	A59	Electronic Blender with Sound Enclosure	 <p>Type of Product: Commercial Blender</p> <p>Capacity: 2 L (Similar or close to capacity).</p> <p>Waring Commercial MX1500XTXP Xtreme 120V Hi-Power. Blender</p> <p>Colour: Black.</p> <p>Blender with Acoustic Enclosure</p> <p>Type of Product: Commercial BlenderCapacity: 2 L</p> <p>Material: Heavy duty Plastic</p> <p>Power: 1800 W</p> <p>Color: BlackDesign</p> <p>StandardSize: 8x12x15 inch. Similar or close to size.</p> <p>Power Source: Electric</p> <p>Usage/Application: Commercial</p> <p>Commercial Blender with Acoustic Enclosure, must have a heavy-duty blending machine designed for use in commercial settings. These blenders are built to</p>	2	Sets
----	-----	---	---	---	------

Appendix A

Revised Section 6 for package 0143

		<p>withstand frequent and high-volume blending tasks, making them more robust and powerful than typical household blenders.</p> <p>Key features and characteristics of commercial blenders:</p> <p>Powerful Motor: Commercial blenders are equipped with high-powered motors, often ranging from 1,000 to 3,000 watts or more. This extra power allows them to blend ingredients quickly and efficiently, including tough items like ice, frozen fruits, and hard vegetables.</p> <p>Durable Construction: They must be built to be more rugged and durable than household blenders. They typically have a heavy-duty plastic housing and are designed to withstand continuous use. Blade Design: Commercial blenders often feature strong and sharp stainless steel blades designed to handle heavy-duty blending tasks. Must have removable blades for easier cleaning and maintenance. Variable Speed.</p> <p>Control: Commercial blenders have variable speed settings, allowing operators to control the blending speed to achieve the desired consistency for various recipes.</p> <p>Pulse Function: Pulse function must provides short bursts of blending power and is useful for precise blending control or breaking down tough ingredients. Large Capacity: Commercial blenders come with larger blending jars or containers, typically ranging from 32 ounces to several liters, to accommodate larger batch sizes.</p> <p>Tamper: This commercial blenders must include a tamper, a tool that helps push ingredients down into the blades, ensuring even blending without the need to stop and scrape the sides of the container. Noise Reduction: While still relatively loud due to their powerful motors, some commercial blenders are designed with noise-reduction features to make them more suitable for busy kitchen environments. Programmable Controls: This advanced models may have programmable settings for specific recipes, making it easier to achieve consistent results. Safety Features:</p>		
--	--	---	--	--

Appendix A

Revised Section 6 for package 0143

		<p>Commercial blenders must have safety features such as overload protection and automatic shut-off to prevent damage to the motor and ensure operator safety.</p> <p>Easy Cleaning: This commercial blenders must have removable blades and jars that are dishwasher safe for easy cleaning.</p> <p>Warranty: Commercial blenders must be with longer and more comprehensive warranties compared to household blenders, reflecting their intended heavy-duty use. Commercial blenders are essential kitchen appliances for businesses that require consistent and efficient blending of ingredients.</p> <p>Use: They are commonly used for making smoothies, soups, sauces, purees, cocktails, and a wide range of other culinary creations in commercial foodservice establishments.</p> <p>The overall appearance of the product shall be as per photograph. Product should be of reputed brand. As per hotel standard.</p>		
--	--	---	--	--

Appendix A

Revised Section 6 for package 0143

64	A60	Chafing Dish	<p style="text-align: center;">SHAPES STAINLESS STEEL RECTANGULAR FULL GLASS LID CHAFFING DISH: With drain outlet and drain cap. The chafing dish also has handles to ensure that the product can be moved with ease.</p>	5	Sets
----	-----	--------------	---	---	------

Appendix A

Revised Section 6 for package 0143

			<p>Specifications: Overall Dimensions: L 23.6 x W 14.6 x H 11.4" Frame Height: 7.9" Alcohol Furnace Height: 2.4" Similar or close to size. Material: Food Grade 304 Stainless Steel and glass (durable), food grade, non toxic, anti rust, dish washer safe. Volume: 9 L / 8 Quart Color: Silver Shape: Rectangle Can Serve: at Least 8 People (Single)</p> <p>Package Includes (for Single Buffet Stove) 1 x Folding Frame. (The frame must include a bottom tray which supports 2 fuel holders to store fuels for heating food) 1 x Cover 1 x Cover Handle 1 x Water Pans 1 x 1/2 + 2 x 1/4 Food pans (Only half+1/4 Size). Highlighted in the picture above. 2 x Fuel Holders Capacity: 8 Quarts (Similar or close to capacity).</p> <p>The overall appearance of the product shall be as per photograph. Product should be of reputed brand. As per hotel standard.</p>			
65	A61	Cloche Service	Room		10	Pcs

Appendix A

Revised Section 6 for package 0143

			<p>Flat top Plate Cover: Dimension: 10.5 inches Dia x H 7 inches Approx. Similar or close to size. Material should be: 304 Stainless steel, food grade, non-toxic, anti-rust, dish washer safe.</p> <p>The overall appearance of the product shall be as per photograph. Product should be of reputed brand. As per hotel standard.</p> <p>Sugico, Shri and sam or equivalent</p>		
66	A62	Cloche Fine Dining	 <p>Dome with knob Plate Cover: Dimension: 10.5 inches Dia x H 7 inches Approx. Similar or close to size. Material should be: 304 Stainless steel, food grade, non-toxic, anti-rust, dish washer safe.</p> <p>The overall appearance of the product shall be as per photograph. Product should be of reputed brand. As per hotel standard.</p> <p>Sugico, Shri and sam or equivalent</p>	10	Pcs

Appendix A

Revised Section 6 for package 0143

67	A63	Dishwashing Machine		2	Pcs																																																																																																																														
			<table border="1" style="width: 100%; border-collapse: collapse;"> <tr><td>Dimensions (w x d x h)</td><td>cm</td><td>57.5 x 60 x 82</td></tr> <tr><td>Rack size</td><td>cm</td><td>50 x 50</td></tr> <tr><td>Distance between rails</td><td>cm</td><td>50.0</td></tr> <tr><td>Door/hood opening</td><td>cm</td><td>36.5</td></tr> <tr><td>Max height of washable glasses</td><td>cm</td><td>32.5</td></tr> <tr><td>Interface setting</td><td></td><td>central</td></tr> <tr><td>General construction</td><td></td><td>partial double wall</td></tr> <tr><td>Door/hood construction</td><td></td><td>full double wall</td></tr> <tr><td>Tank volume</td><td>lt</td><td>20</td></tr> <tr><td>Tank heating element</td><td>w</td><td>1,400</td></tr> <tr><td>Tank surface strainers</td><td></td><td>composite material</td></tr> <tr><td>Boiler type</td><td></td><td>pressurized</td></tr> <tr><td>Boiler volume</td><td>lt</td><td>6</td></tr> <tr><td>Anti back-flow valve</td><td></td><td>yes</td></tr> <tr><td>Boiler heating element</td><td>w</td><td>4,900</td></tr> <tr><td>Wash pump type</td><td></td><td>double flow</td></tr> <tr><td>Wash pump power</td><td>w</td><td>600</td></tr> <tr><td>Wash temperature</td><td>°C</td><td>50</td></tr> <tr><td>Upper wash arm</td><td></td><td>Standard // wash & rinse arm</td></tr> <tr><td>Lower wash arm</td><td></td><td>Standard // wash & rinse arm</td></tr> <tr><td>Rinse temperature</td><td>°C</td><td>80</td></tr> <tr><td>Rinse water consumption</td><td>lt/cycle</td><td>2.2</td></tr> <tr><td>Optimal external water pressure</td><td>bar</td><td>2.0</td></tr> <tr><td>Upper rinse arms (nozzles)</td><td></td><td>Standard // wash & rinse arm</td></tr> <tr><td>Lower rinse arms (nozzles)</td><td></td><td>Standard // wash & rinse arm</td></tr> <tr><td>Drain system</td><td></td><td>ArchiMedez (eff. 83%)</td></tr> <tr><td>Drain pump</td><td></td><td>kit</td></tr> <tr><td>Rinse aid dispenser</td><td></td><td>peristaltic built in</td></tr> <tr><td>Detergent dispenser</td><td></td><td>peristaltic built in</td></tr> <tr><td>Chemical products probe</td><td></td><td>not available</td></tr> <tr><td>Wash cycle 1</td><td>sec</td><td>50</td></tr> <tr><td>Wash cycle 2</td><td>sec</td><td>90</td></tr> <tr><td>Wash cycle 3</td><td>sec</td><td>180</td></tr> <tr><td>Self cleaning cycle</td><td></td><td>ProSelf</td></tr> <tr><td>Electric power</td><td>w</td><td>6,800</td></tr> <tr><td>Electric connection</td><td>V/Hz/ph</td><td>400/50/3N</td></tr> <tr><td>Fuse</td><td>Amp</td><td>16</td></tr> <tr><td>Racks for 16 plates</td><td>n</td><td>1</td></tr> <tr><td>Flat racks</td><td>n</td><td>1</td></tr> <tr><td>Electric cable</td><td>n</td><td>1</td></tr> <tr><td>Drain hose</td><td>n</td><td>1</td></tr> <tr><td>Fill hose</td><td>n</td><td>1</td></tr> </table>	Dimensions (w x d x h)	cm	57.5 x 60 x 82	Rack size	cm	50 x 50	Distance between rails	cm	50.0	Door/hood opening	cm	36.5	Max height of washable glasses	cm	32.5	Interface setting		central	General construction		partial double wall	Door/hood construction		full double wall	Tank volume	lt	20	Tank heating element	w	1,400	Tank surface strainers		composite material	Boiler type		pressurized	Boiler volume	lt	6	Anti back-flow valve		yes	Boiler heating element	w	4,900	Wash pump type		double flow	Wash pump power	w	600	Wash temperature	°C	50	Upper wash arm		Standard // wash & rinse arm	Lower wash arm		Standard // wash & rinse arm	Rinse temperature	°C	80	Rinse water consumption	lt/cycle	2.2	Optimal external water pressure	bar	2.0	Upper rinse arms (nozzles)		Standard // wash & rinse arm	Lower rinse arms (nozzles)		Standard // wash & rinse arm	Drain system		ArchiMedez (eff. 83%)	Drain pump		kit	Rinse aid dispenser		peristaltic built in	Detergent dispenser		peristaltic built in	Chemical products probe		not available	Wash cycle 1	sec	50	Wash cycle 2	sec	90	Wash cycle 3	sec	180	Self cleaning cycle		ProSelf	Electric power	w	6,800	Electric connection	V/Hz/ph	400/50/3N	Fuse	Amp	16	Racks for 16 plates	n	1	Flat racks	n	1	Electric cable	n	1	Drain hose	n	1	Fill hose	n	1		
Dimensions (w x d x h)	cm	57.5 x 60 x 82																																																																																																																																	
Rack size	cm	50 x 50																																																																																																																																	
Distance between rails	cm	50.0																																																																																																																																	
Door/hood opening	cm	36.5																																																																																																																																	
Max height of washable glasses	cm	32.5																																																																																																																																	
Interface setting		central																																																																																																																																	
General construction		partial double wall																																																																																																																																	
Door/hood construction		full double wall																																																																																																																																	
Tank volume	lt	20																																																																																																																																	
Tank heating element	w	1,400																																																																																																																																	
Tank surface strainers		composite material																																																																																																																																	
Boiler type		pressurized																																																																																																																																	
Boiler volume	lt	6																																																																																																																																	
Anti back-flow valve		yes																																																																																																																																	
Boiler heating element	w	4,900																																																																																																																																	
Wash pump type		double flow																																																																																																																																	
Wash pump power	w	600																																																																																																																																	
Wash temperature	°C	50																																																																																																																																	
Upper wash arm		Standard // wash & rinse arm																																																																																																																																	
Lower wash arm		Standard // wash & rinse arm																																																																																																																																	
Rinse temperature	°C	80																																																																																																																																	
Rinse water consumption	lt/cycle	2.2																																																																																																																																	
Optimal external water pressure	bar	2.0																																																																																																																																	
Upper rinse arms (nozzles)		Standard // wash & rinse arm																																																																																																																																	
Lower rinse arms (nozzles)		Standard // wash & rinse arm																																																																																																																																	
Drain system		ArchiMedez (eff. 83%)																																																																																																																																	
Drain pump		kit																																																																																																																																	
Rinse aid dispenser		peristaltic built in																																																																																																																																	
Detergent dispenser		peristaltic built in																																																																																																																																	
Chemical products probe		not available																																																																																																																																	
Wash cycle 1	sec	50																																																																																																																																	
Wash cycle 2	sec	90																																																																																																																																	
Wash cycle 3	sec	180																																																																																																																																	
Self cleaning cycle		ProSelf																																																																																																																																	
Electric power	w	6,800																																																																																																																																	
Electric connection	V/Hz/ph	400/50/3N																																																																																																																																	
Fuse	Amp	16																																																																																																																																	
Racks for 16 plates	n	1																																																																																																																																	
Flat racks	n	1																																																																																																																																	
Electric cable	n	1																																																																																																																																	
Drain hose	n	1																																																																																																																																	
Fill hose	n	1																																																																																																																																	



Appendix A

Revised Section 6 for package 0143

			<p>Similar or close to size.</p> <p>The overall appearance of the product shall be as per photograph. Product should be of reputed brand. As per hotel standard. IFB, Omega or Equivalent</p>		
68	A64	Glass Washer	 <p>Features: With open final rinsing. Cleans all glasses, from normal glasses to beer glasses and all types of glasses up to a depth of 24cm, lightly and swiftly. Fast and simply economical: One just have to clean one rinsing canister. Fits into any bar sinks larger than 33x19cm.</p> <p>It must fit into any bar counter and connect to the water pipping.</p> <p>Dimensions:</p> <p>Lenght: 33cm Apporx</p> <p>Height: 33cm Apporx</p> <p>Width: 19cm Apporx</p> <p>Similar or close to size.</p> <p>Material: 304 Stainless steel, anti-rust.</p> <p>The overall appearance of the product shall be as per photograph. Product should be of reputed brand. As per hotel standard.</p> <p>SPULBOY or equivalent.</p>	8	Pcs



Appendix A

Revised Section 6 for package 0143

69	A65	Escargot Fork	 <p>Dimension: Length 6" Similar or close to size. Material: 304 Stainless Steel, food grade, non-toxic, anti-rust, dish washer safe.</p> <p>The overall appearance of the product shall be as per photograph. Product should be of reputed brand. As per hotel standard. SAFICO, Borosil, Shri & Sam or Equivalent</p>	12	Pcs
70	A66	Escargot Tong	 <p>Dimension: Length: 15CM, Width 6CM, Height: 3.5CM Similar or close to size. Material: 304 Stainless Steel, food grade, non-toxic, anti-rust, dish washer safe.</p> <p>The overall appearance of the product shall be as per photograph. Product should be of reputed brand. As per hotel standard. SAFICO, Borosil, Shri & Sam or Equivalent</p>	12	Pcs
71	A67	Latte Glass		30	Pcs



Appendix A

Revised Section 6 for package 0143

			<p>Glass Coffee Culture: Dimension: Ø 8 x H 11.5cm Similar or close to size. Material: Glass, transparent, metal holder glass coffee, dish washer safe.</p> <p>The overall appearance of the product shall be as per photograph. Product should be of reputed brand. As per hotel standard. OCEAN, Borosil, or Equivalent.</p>		
72	A68	Irish Coffee Glass	 <p>Glass Iris Coffee: Capacity: 24cl Similar or close to capacity. Material: Glass, transparent, with handle and base stand, dish washer safe.</p> <p>The overall appearance of the product shall be as per photograph. Product should be of reputed brand. As per hotel standard. OCEAN, Borosil, or Equivalent.</p>	20	Pcs
73	A69	Irish Coffee Burner	 <p>Should come with spirit lamp with a stand. Dimension: L 12 x W 6.5 x H 11.5 cm Similar or close to size. Material: 304 stainless steel, anti-rust.</p>	2	Pcs



Appendix A

Revised Section 6 for package 0143

			The overall appearance of the product shall be as per photograph. Product should be of reputed brand. As per hotel standard.		
74	A70	Coffee Pot	 <p>Decanter Coffee with Lid:</p> <p>Capacity: 1000 ml (12 cups) minimum. Similar or close to capacity. Material: Glass, transparent with heat resistant plastic handle and lid as picture. With bottom coating for heating purpose. Dish washer safe.</p> <p>The overall appearance of the product shall be as per photograph. Product should be of reputed brand. As per hotel standard. OCEAN, Borosil, or Equivalent.</p>	5	Pcs
75	A71	Coffee Cups & Saucer	 <p>Each set contains: One cup and One saucer. Ensure cup fits on saucer. Dimension: Cup Americano: Depth 10 cm Saucer: Round 16 cm Dia Similar or close to size. Material: Ceramic, dish washer and microwave safe. Colour: white</p>	60	Sets

Appendix A

Revised Section 6 for package 0143

			<p>The overall appearance of the product shall be as per photograph. Product should be of reputed brand. As per hotel standard. CHURCHILL, Borosil, or Equivalent.</p>		
76	A72	Espresso Cups & Saucer	 <p>Each set contains: One cup and One saucer. Ensure cup fits on saucer. Dimension: Cup Espresso: Dia: 6.4 cm, H: 7 cm Saucer: Espresso 12cm Dia</p> <p>Capacity: 50 ml Similar or close to size. Material: Ceramic, dish washer and microwave safe. Colour: white</p> <p>The overall appearance of the product shall be as per photograph. Product should be of reputed brand. As per hotel standard. CHURCHILL, Borosil, or Equivalent.</p>	30	Sets
77	A73	Cappuccino Cups & Saucer	 <p>Each set contains: One cup and One saucer. Ensure cup fits on saucer.</p> <p>Dimension: Saucer: Espresso 16 cm Dia</p> <p>Capacity: Cup capacity 240 ml</p> <p>Similar or close to size.</p> <p>Material: Ceramic, dish washer and microwave safe. Colour: white</p>	30	Sets

Appendix A

Revised Section 6 for package 0143

			<p>The overall appearance of the product shall be as per photograph. Product should be of reputed brand. As per hotel standard.</p> <p>CHURCHILL, Borosil, or Equivalent.</p>		
78	A74	Ice Blender (Cold Coffee Drinks)	 <p>Ice blender: Each set contains: One Machine with jug as in picture. Dimension: L 170 x D 220 x H 480 mm Similar or close to size. Capacity: Jug capacity 2 Litres</p> <p>Power: Above 500 W</p> <p>Automation Type: Automatic</p> <p>Type: Power Blender</p> <p>Material : Poly Carbonate</p> <p>Usage/ Application: Commercial</p> <p>Colour: Black base with transparent jar</p> <p>Blade Type: Multipurpose Blade</p> <p>Voltage: 220 V</p>	1	Set

Appendix A

Revised Section 6 for package 0143

			<p>Phase: Single Phase</p> <p>Blender & Crusher: This must be a 6-in-1 multifunctional blender that can make vegetable juices, milkshakes, smoothies, soy milk, hot soups, frozen desserts, cereal powder, crushed ice.</p> <p>2200W Powerful Motor & 6 Blade: Professional blender the powerful 2200W professional blender must be with up to 32000 RPM can break the cell walls of both soft and hard ingredients in seconds. Must have (6 lengthened optional) sharp blades makes blending range wider and more efficient.</p> <p>Variable Speed & Pulse Control: Blender must be with a versatile variable speed control by rotating the knob during operation to achieve your desired textures. Pulse mode to crush ice quickly for frozen drinks and cocktail. Should be perfect for making large batches of creamy, frozen drinks.</p> <p>Detachable for Easy Cleaning: Cleaning this countertop blender should be very easy. Should be cleaned with dish soap to warm water and run the blender. It also should be disassembled for thorough cleaning and is dishwasher safe. Anti-slip rubber feet keep mixers firmly on the countertop, suitable for business use.</p> <p>2 L Big Capacity & Worry-Free Purchase: It must have a 2 L large capacity.</p> <p>The overall appearance of the product shall be as per photograph. Product should be of reputed brand. As per hotel standard.</p>		
79	A75	Coffee Cloths for Espresso Machine	 <p>Dimension: L 12" x W 12", Similar or close to size.</p>	20	Pcs

Appendix A

Revised Section 6 for package 0143

			<p>Material - Microfiber cloth, cotton.</p> <p>Colour: Various Colours.</p> <p>The overall appearance of the product shall be as per photograph. Product should be of reputed brand. As per hotel standard.</p>		
80	A76	Iron – cordless	 <p>Safe on all ironable fabrics: Even delicate like silk.</p> <p>Power: 1250 w or more</p> <p>Soleplate gliding performance: 4 stars.</p> <p>Soleplate: Steam Glide</p> <p>Water tank capacity: 1300 ml</p> <p>Hose length: 1.6 m.</p> <p>Integrated power plug</p> <p>Power cord length: 1.65 m</p> <p>Precision steam tip</p> <p>Ready to use: Light indicator, Sound indicator.</p>	3	Pcs

Appendix A

Revised Section 6 for package 0143

			<p>Refill any time during use.</p> <p>Soleplate scratch resistance: 4 stars</p> <p>For all ironable fabrics</p> <p>No burns</p> <p>No temperature settings are needed.</p> <p>ProVelocity steam engine</p> <p>Cordless iron with charger stand.</p> <p>Weight of iron: 1,3 kg approx.</p> <p>Weight of iron + base: 2,72 kg approx.</p> <p>Calc clean container</p> <p>Similar or advance design.</p> <p>The overall appearance of the product shall be as per photograph. Product should be of reputed brand. As per hotel standard.</p> <p>Phillips, Havells or equivalent.</p>		
81	A77	Moulton for tables	 <p>Moulton:</p> <p>Dimension:</p> <p>1. Rectangular: L 29.5 x W 25.5" x 40pcs</p>	42	Pcs



Appendix A

Revised Section 6 for package 0143

			<p>2. Round: 125cm round x 1pc 3. Round: 186cm round x 1pc</p> <p>Similar or close to size.</p> <p>Material: PVC faced Moulton fabric should be waterproof, stain resistant and protect the underlaying table. Must fit any table. Include Velcro edge to help secure table skirting.</p> <p>Should be elastic so can stretch to cover the table.</p> <p>Colour: White</p> <p>The overall appearance of the product shall be as per photograph. Product should be of reputed brand. As per hotel standard.</p>		
82	A78	Coffee Ladle with Spout	 <p>Ladle Spout: Dimension: L 27.9 cm Similar or close to size. Material should be: 304 Stainless steel, non-toxic, anti-rust, dish washer safe.</p> <p>The overall appearance of the product shall be as per photograph. Product should be of reputed brand. As per hotel standard.</p>	2	Pcs

Appendix A

Revised Section 6 for package 0143

83	A79	Coffee Bean Storing Tins	 <p>Capacity: Minimum 1.8 litres Similar or close to capacity. Material: 304 Stainless Steel with a glass window, airtight container. Food grade, nontoxic, anti-rust, dish washer safe. Colour: Steel Gray</p> <p>The overall appearance of the product shall be as per photograph. Product should be of reputed brand. As per hotel standard.</p>	4	Pcs
84	A80	Latte Spoons/Soda Spoon	 <p>Spoon Soda: Dimension: L 19.5 cm Similar or close to size. Material should be: 304 Stainless steel, non-toxic, anti-rust, dish washer safe.</p> <p>The overall appearance of the product shall be as per photograph. Product should be of reputed brand. As per hotel standard.</p>	10	Pcs



Appendix A

Revised Section 6 for package 0143

85	A81	Corking Machine	 <p>The Wine Bottle Floor Corker makes bottling wine easy. Procedure should be: simply add a cork, push the lever. The spring-loaded lever instantly gives a perfectly corked bottle. Each of the 3 corker legs include holes for mounting or securing to the floor (installation hardware not included). The floor corker is super lightweight but constructed of rolled steel and hard plastic materials. There are no flimsy joints or rivets, even when exerting pressure while corking. All standard 750mL bottles can be used with a variety of cork sizes including #7, #8, and #9. Since the plunger depth is adjustable, it also works with the Belgian beer bottle corks, champagne bottles with wine corks, and synthetic plastic corks.</p> <p>Easy to Use: like when a cork added to this Wine Bottle Floor Corker, push down on the lever, and the cork goes into the bottle with ease.</p> <p>Durable: Rolled steel construction with plastic handle</p> <p>Comfortable Grip: Fit-molded plastic red handle for a firm grip</p> <p>Versatile: Works with all straight #7, #8, and #9 size corks; includes adjustable plunger depth</p> <p>Material: Metal with colour coat (Portuguese-Red)</p> <p>Similar or close to size (Standard size)</p> <p>The overall appearance of the product shall be as per photograph. Product should be of reputed brand. As per hotel standard.</p>	2	Pcs
----	-----	-----------------	---	---	-----



Appendix A

Revised Section 6 for package 0143

86	A82	Room Service Tray	 <p>Large Serving Tray, Tray with Cutout Handles:</p> <p>Dimensions: L 40 x W 27 x H 5 Centimeters Similar or close to size. Shape: Rectangular Material: Wood Colour: Brown</p> <p>The overall appearance of the product shall be as per photograph. Product should be of reputed brand. As per hotel standard.</p>	10	Pcs
87	A83	Room Service Trolley with Hot Box	 <p>Dimensions: Trolley Size: L:109.5 x W:91.5 X H:74.2 CM Hotbox Size: L:38 x W:39.2 X H:51 CM Similar or close to size. Material: Laminated wooden top, Powder coated Steel frame with Wooden box. With foldable sides: like in picture. Wheel/Caster with lock system.</p> <p>Similar or equivalent design.</p>	4	Pcs

Appendix A

Revised Section 6 for package 0143

			The overall appearance of the product shall be as per photograph. Product should be of reputed brand. As per hotel standard.		
88	A84	Milk Jug	 <p>Jug Milk: Dimension: H 7 x Dia 6 cm Similar or close to size. Material: Ceramic, dish washer and microwave safe, with handle and pout. The overall appearance of the product shall be as per photograph. Product should be of reputed brand. As per hotel standard. CHURCHILL, Borosil, or Equivalent.</p>	40	Pcs
89	B1	5 tiers shelves	 <p>Dimension: W 80 x D 40 x H 173.4 cm Similar or closer to the size. Colour: 2 Red Selves, 2 White Shelves Weight capacity: Must 250 kg minimum, each shelve capacity must be 25 kg minimum. Material: Medium density composite (engineered wood) woods boards. Wood laminated glossy finish. All edges covered with PVC edge beading of same colour. Must be constructed from high-quality certified environmentally preferred laminated stable amongst the medium density composite (engineered wood) woods boards, supportive, and without a pungent smell, durable, which must ensure sturdy, and durable. It should be anti-scratch, moisture proof, stain-resistant and dust resistant, termite proof, water-resistant, and rustproof. Closed back with a high-quality wood laminated material. Have a back panel with open from front side. This display shelf should be a free-standing furniture unit with 5</p>	4	Pcs



Appendix A

Revised Section 6 for package 0143

			<p>horizontal stacks of racks or shelves, each rack divided into half, which are used for varied purposes to store or display objects.</p> <p>The overall appearance of the product shall be as per photograph. Product should be of reputed brand. As per hotel standard.</p>		
90	B2	Banquet Round Tables	 <p>Two different size table: Dimensions:</p> <ol style="list-style-type: none"> 1. One Table Round Ø4' with powder coated steel legs. 2. One Table Round Ø6' with powder coated steel legs. <p>Similar or closer to the size. Material: Medium density composite (engineered wood) woods boards. laminated top, foldable legs. Sides: White laminated. Bottom brown laminated. Legs epoxy powder coated metal (steel or equivalent). Colour: is white on the surface and bottom is wood and brown. All edges covered with PVC edge beading.</p> <p>It should be anti-scratch, moisture proof, stain-resistant and dust resistant, termite proof, water-resistant, and rustproof. Closed back with a high-quality wood laminated material.</p> <p>Capacity: Must be able carry weight of 250 kg minimum.</p> <p>The overall appearance of the product shall be as per photograph. Product should be of reputed brand. As per hotel standard.</p>	2	Pcs

Appendix A

Revised Section 6 for package 0143

91	B3	Chair	 <p>Chair Without Arm Rest: Dimension: Total Height-860mm, Width 400mm, Depth 500mm, Seat Height-450mm. Similar or closer to the size. Material: Under structure made from PVC moulded shell. Seat one piece PP moulded shell with ergonomic seating contour. Stackable Capacity: Must be able carry weight of 150 kg minimum.</p> <p>The overall appearance of the product shall be as per photograph. Product should be of reputed brand. As per hotel standard.</p>	60	Pcs
92	B4	Table	 <p>Dimension: Square tabletop: L 650 X W 650 mm, Height: 750 mm X thick 25 mm. Similar or closer to the size. Material: Medium density composite (engineered wood) woods boards. laminated top and back. Frame made of 1.2 mm thick M.S. cold rolled close annealed tube duly powder coated/ chrome plated or equivalent material. Fitted with 25mm Pre-laminated Board top. All edges covered with PVC edge beading. It should be anti-scratch, moisture proof, stain-resistant and dust resistant, termite proof, water-resistant, and rustproof. Closed back with a high-quality wood laminated material. Colour: Ivory or equivalent</p>	50	Pcs



Appendix A

Revised Section 6 for package 0143

			<p>Metal bases stand All steel components are epoxy powder coated after seven tanks anti corrosion treatment of surface. Light Weight easily moved.</p> <p>Capacity: Must be able carry weight of 200 kg minimum.</p> <p>The overall appearance of the product shall be as per photograph. Product should be of reputed brand. As per hotel standard.</p>		
93	B5	Oblong table	 <p>Oblong Folding: Dimension: W 2.5 FT x L 6 FT X H 2.5 FT Similar or closer to the size. Material: Medium density composite (engineered wood) woods boards. laminated top and back. Frame made of 1.2 mm thick M.S. cold rolled close annealed tube duly powder coated/ chrome plated or equivalent material. Fitted with 25mm Pre-laminated Board top. All edges covered with PVC edge beading. It should be anti-scratch, moisture proof, stain-resistant and dust resistant, termite proof, water-resistant, and rustproof. Closed back with a high-quality wood laminated material. Colour: White Metal bases stand All steel components are epoxy powder coated after seven tanks anti corrosion treatment of surface. Light Weight easily moved. With foldable legs. Capacity: Must be able carry weight of 250 kg minimum.</p> <p>The overall appearance of the product shall be as per photograph. Product should be of reputed brand. As per hotel standard.</p>	4	Pcs

Appendix A

Revised Section 6 for package 0143

94	B6	IBM table	 <p>IBM Table: Dimension: L 180 x W 45 cm x H 75cm Similar or closer to the size. Material: Medium density composite (engineered wood) woods boards. laminated top and back. Frame made of 1.2 mm thick M.S. cold rolled close annealed tube duly powder coated/ chrome plated or equivalent material. Fitted with 25mm Pre-laminated Board top. All edges covered with PVC edge beading. It should be anti-scratch, moisture proof, stain-resistant and dust resistant, termite proof, water-resistant, and rustproof. Closed back with a high-quality wood laminated material. Colour: White Metal bases stand All steel components are epoxy powder coated after seven tanks anti corrosion treatment of surface. Light Weight easily moved. With foldable legs. Capacity: Must be able carry weight of 250 kg minimum.</p> <p>The overall appearance of the product shall be as per photograph. Product should be of reputed brand. As per hotel standard.</p>	4	Pcs
95	B7	Cocktail round table	 <p>Round table: Dimension: 30" Dia x 3-3.5 ft, H 3.5 Approx. Similar or closer to the size. Material: Medium density composite (engineered wood) woods boards. laminated top and back. Frame made of 1.2 mm thick M.S. cold rolled close annealed tube duly powder coated/</p>	2	Pcs

Appendix A

Revised Section 6 for package 0143

			<p>chrome plated or equivalent material. Fitted with 25mm Pre-laminated Board top. All edges covered with PVC edge beading.</p> <p>It should be anti-scratch, moisture proof, stain-resistant and dust resistant, termite proof, water-resistant, and rustproof. Closed back with a high-quality wood laminated material.</p> <p>Colour: Brown</p> <p>Metal bases stand All steel components are epoxy powder coated after seven tanks anti corrosion treatment of surface.</p> <p>Light Weight easily moved.</p> <p>Capacity: Must be able carry weight of 200 kg minimum.</p> <p>The overall appearance of the product shall be as per photograph. Product should be of reputed brand. As per hotel standard.</p>		
96	B8	Side station	 <p>Dimension - 91cm x 51cm x H 91cm Approx. Similar or closer to the size.</p> <p>Material: Medium density composite (engineered wood) woods boards (1 inch thick). All edges covered with PVC edge beading.</p> <p>It should be anti-scratch, moisture proof, stain-resistant and dust resistant, termite proof, water-resistant, and rustproof. Closed back with a high-quality wood laminated material.</p> <p>With 2 drawers Easy moving on rollers. The top with raised edges 2.5 inches minimum.</p> <p>With 2 door cupboards with a detachable shelve and easy moving doors and drawers with handle (Anti rust) with a stopper.</p> <p>Colour: Dark Brown</p> <p>Capacity: Must be able carry weight of 350 kg minimum.</p> <p>The overall appearance of the product shall be as per photograph. Product should be of reputed brand. As per hotel standard.</p>	4	Pcs



Appendix A

Revised Section 6 for package 0143

97	B9	Host Stand	 <p>Dimension - Black top - 87cm x 20cm x 64cm HT White area - 80cm x 46cm x 64cm HT</p> <p>Similar or closer to the size and design.</p> <p>Material: Material: Medium density composite (engineered wood) woods boards (1.5 inches thick minimum). All edges covered with PVC edge beading.</p> <p>It should be anti-scratch, moisture proof, stain-resistant and dust resistant, termite proof, water-resistant, and rustproof. Closed back with a high-quality wood laminated material.</p> <p>Front - Logo of WSC or F&B Back - 2 drawer 2 door cupboard</p> <p>Colour: Dark brown and white, as per picture Capacity: Must be able carry weight of 350 kg minimum.</p> <p>The overall appearance of the product shall be as per photograph. Product should be of reputed brand. As per hotel standard.</p>	1	Pc
98	B10	Chair cover	<p>Material: Spandex Colour: Four-way White Special Feature: Stretch Fit Product Care: Must be machine washable. Closure Type: Elastic Fits all types of plastic chairs without handle. Four ways stretchable, strong and everlasting, durable, reusable, washable.</p> <p>The overall appearance of the product shall be as per photograph. Product should be of reputed brand. As per hotel standard.</p>	50	Pcs
99	B11	Tablecloth	<p>Dimension: 3 sizes will be needed:</p> <ol style="list-style-type: none"> 1. W 56 x L 62" (20pcs) 2. W 56 x L 87" (30pcs) 3. W56 x L 112" (10pcs) 	60	Pcs

Appendix A

Revised Section 6 for package 0143

			<p>Similar or closer to the size. Material: 100% cotton (Good quality), machine washable. Colour: White Durable, Reusable, Comfortable, Washable.</p> <p>The overall appearance of the product shall be as per photograph. Product should be of reputed brand. As per hotel standard.</p>				
100	B12	Cocktail underlay	<table style="width: 100%; border: none;"> <tr> <td style="width: 15%; text-align: center; vertical-align: middle;">  </td> <td style="padding-left: 10px;"> <p>Cocktail table underlay: Dimension: 30 inches Dia x H 40 inches Similar or closer to the size. Material: Spandex Colour: Four-way Black Special Feature: Stretch Fit Product Care: Must be machine washable. Closure Type: Elastic Colour - Black or any other similar solid colour. Stretch Tablecloth Spandex Round Durable, Reusable, Comfortable, Washable</p> <p>The overall appearance of the product shall be as per photograph. Product should be of reputed brand. As per hotel standard.</p> </td> </tr> </table>		<p>Cocktail table underlay: Dimension: 30 inches Dia x H 40 inches Similar or closer to the size. Material: Spandex Colour: Four-way Black Special Feature: Stretch Fit Product Care: Must be machine washable. Closure Type: Elastic Colour - Black or any other similar solid colour. Stretch Tablecloth Spandex Round Durable, Reusable, Comfortable, Washable</p> <p>The overall appearance of the product shall be as per photograph. Product should be of reputed brand. As per hotel standard.</p>	4	Sets
	<p>Cocktail table underlay: Dimension: 30 inches Dia x H 40 inches Similar or closer to the size. Material: Spandex Colour: Four-way Black Special Feature: Stretch Fit Product Care: Must be machine washable. Closure Type: Elastic Colour - Black or any other similar solid colour. Stretch Tablecloth Spandex Round Durable, Reusable, Comfortable, Washable</p> <p>The overall appearance of the product shall be as per photograph. Product should be of reputed brand. As per hotel standard.</p>						

Appendix A

Revised Section 6 for package 0143

101	B13	Banquet Chairs	 <p>Chair Without Arm Rest: Dimension: Total Height-860mm, Width 400mm, Depth 500mm, Seat Height-450mm. Similar or closer to the size. Material: Under structure made from PVC moulded shell. Seat one piece PP moulded shell with ergonomic seating contour. Stackable Capacity: Must be able carry weight of 150 kg minimum.</p> <p>The overall appearance of the product shall be as per photograph. Product should be of reputed brand. As per hotel standard.</p>	40	Pcs
102	B14	Banquet Trolley	 <p>Dimension: D 16" x W 32" x H 33" Similar or closer to the size. Shape: Rectangular</p>	2	Pcs



Appendix A

Revised Section 6 for package 0143

			<p>Handle at both sides, for easy movement from all sides. Side encloses, at least 3 inches and frame with powder coated cast iron or equivalent material. 3 horizontal shelves, at equal division, adjustable, carbon coloured, 4 swivel castors, 4 smooth running wheels (picture shows wheels with brass caps, Swivel wheel/caster, noise free with lock system). Material: 304 stainless steel, 3 shelves made of acid-resistant laminate, anti-scratch, moisture proof, stain-resistant and dust resistant, termite proof, water-resistant, and rustproof. with solid wood frame. Use: Hotel Trolley, Commercial Furniture Can carry 150 kg weight minimum.</p> <p>The overall appearance of the product shall be as per photograph. Product should be of reputed brand. As per hotel standard.</p>		
103	B15	Pleated Table Cover Skirting	 <p>Dimension: L 17 ft x H 2.9 ft minimum (Standard) Similar or closer to the size. Material: Polyester fitted pleated tablecloth table skirt, stain proof, durable, reusable, comfortable, washing machine safe, washable. Colour: White</p> <p>The overall appearance of the product shall be as per photograph. Product should be of reputed brand. As per hotel standard.</p>	10	Pcs

Appendix A

Revised Section 6 for package 0143

104	B16	Napkins	 <p>Table Napkin: Dimension: L 20" x W 20" Similar or closer to the size. Material: White cloth 100% cotton napkins, side folded and stitched.</p> <p>Colour: White</p> <p>The overall appearance of the product shall be as per photograph. Product should be of reputed brand. As per hotel standard.</p>	120	Pcs
105	B17	Overlay	 <p>For IBM Oblong Folding: Dimension: W 2.5 FT x L 6 FT Similar or closer to the size. For IBM Folding Table Size is: 5.9 ft x 1.48 ft Material: Spandex Colour: Four-way Black Special Feature: Stretch Fit Product Care: Must be machine washable. Closure Type: Elastic Colour - Black or any other similar solid colour. Stretch Tablecloth Spandex Round Durable, Reusable, Comfortable, Washable</p>	20	Pcs



Appendix A

Revised Section 6 for package 0143

			<p>The overall appearance of the product shall be as per photograph. Product should be of reputed brand. As per hotel standard.</p>			
106	B19	Drinks shelve	display	 <p>Design as per picture. Dimensions: L 120 cm x H 210 cm x W 30 cm Similar or closer to the size. Material: Strong, durable, and sturdy acrylic bracket white from inside and black from outside. Glass selves must be of 1 cm thickness minimum. The shelves must be adjustable, so one can adjust them as required to fit. A total of 4 display shelves are included + the bottom base. For a total of 5 shelves. Display case must be standard with 98% UV Acrylic (98% UV Ultra Clear Protected Acrylic Door)2 way opening doors (plexiglass) with metal handle. A must have for protection from the sunlight, as well as keeping dust out. Heavy Duty lockable latches with keys, keep the case safe and secure. Case must come fully assembled with all mounting hardware included. Equal space between shelves and must be adjustable as per requirement. Lights: With LED light on sides & top.</p> <p>The overall appearance of the product shall be as per photograph. Product should be of reputed brand. As per hotel standard.</p>	2	Set

Appendix A

Revised Section 6 for package 0143

107	B20	Wine Barrel	 <p>Wooden Barrel: Dimension: 42cm (Top) x 59cm (Middle) x 100cm (H)</p> <p>Similar or close to size.</p> <p>Shape: Round (vertical)</p> <p>Storage Material: Wine, chemicals, food products.</p> <p>Material: Tank Material: Oak wood with anti-rust metal brackets (6 nos.)</p> <p>Colour: Wood finish</p> <p>The overall appearance of the product shall be as per photograph. Product should be of reputed brand. As per hotel standard.</p>	2	Pcs
108	B21	2-door Reach-in Counter Chiller	 <p>Dimension</p> <ul style="list-style-type: none"> • L 1500mm x W 750mm x H 800mm (Approx.) <p>Similar or closer to the size.</p> <p>Key Requirements</p> <ul style="list-style-type: none"> • Chiller temperature range: -1/+1°C to +4/+6°C. • Auto condensate evaporating system. 	2	Pc

Appendix A

Revised Section 6 for package 0143

			<ul style="list-style-type: none"> • Stainless steel work top min 1.5mm thickness • Stainless steel exterior body min 1.0mm thickness • Able to operate at approx. 40°C ambient temperature. • Digital temperature indicator and controller. • Stainless Steel AISI 304 • HACCP Certified or equivalent. • Equipment to have adjustable 3-tier storage capability. • Pass Through <p>Voltage: 220V – 240V / 50Hz - 60Hz / 1 Phase</p> <p>The overall appearance of the product shall be as per photograph. Product should be of reputed brand. As per hotel standard.</p>		
109	B22	1-door Reach-in Counter Chiller	 <p>This item should be on castor wheels so that easy to pull out if any to repair water pipes for the Coffee machine.</p> <p>Dimensions: L 90 cm x W 60 cm x H 70 cm. Height with castor wheels is 75 cm. Similar or closer to the size. Capacity: 3 GN 1/1 of 100mm depth Similar or closer to the capacity. • Temperature: 0°C to 4°C approx.. Body Material: Metal Door Type: Single Door Number of Doors: 1 Door</p>	4	Pcs

Appendix A

Revised Section 6 for package 0143

			<p>Power Source: Electric Defrost Type: Auto-Defrost Usage/Application: Commercial Voltage: 240V Phase: Single Shelves Number: 5 Shelves detachable. Frequency: 50Hz Sturdy stainless steel construction.</p> <ul style="list-style-type: none"> • forced draft cooling • Easy to remove louvers for cleaning of condenser • Hinges for easy opening and closing of doors <p>Lockable doors</p> <ul style="list-style-type: none"> • Automatic defrost, cycle and condensate heater • 1 nos. anti corrosive wire shelf of size GN 1/1 per door • Coved corners • Designed to operate at 43° C ambient • Digital temperature controller <p>Or equivalent</p> <p>Material - Stainless steel The dimension needs to be measured with the barista counter, must fit with barista counter.</p> <p>The overall appearance of the product shall be as per photograph. Product should be of reputed brand. As per hotel standard.</p> <p>Blue star, LG, Samsung or equivalent</p>		
110	B23	Ice Maker Machine		2	Pcs



Appendix A

Revised Section 6 for package 0143

		<p>Ice production limit per day (24hrs) 55kg Approx. Measurement: Length 44.8cm, Height 79.8cm, Width 40cm Approx. Similar or closer to the size. Material: Stainless Steel Frequency: 60 Hz Surface Finish: Polished Usage/Application Ice Cube Making Others: Input Power: 180W,280W,240W Power supply: AC 220V / 50Hz Storage Capacity: 10 kg approx. Capacity of Ice flake: 50kg minimum in 24 hrs. Water Supply: 3 / 4 inch BSP Fully Automatic microprocessor control. Stainless Steel construction Continuous Ice Flakes Output CFC free compressor Low water level Indication Overload protection Noiseless operation Compact Design and low maintenance. Voltage: 220 V Phase: Single Phase Power Source: Electric With wheels and wheel lock system.</p> <p>The overall appearance of the product shall be as per photograph. Product should be of reputed brand. As per hotel standard.</p>		
--	--	--	--	--

Appendix A

Revised Section 6 for package 0143

111	B24	Standing Desk	 <p>Dimension – L 600 x W 400mm Approx. Similar or closer to the size. Metal base and stem (adjustable height) Material: Medium density composite (engineered wood) woods boards (1.5 inches thick minimum), laminated. All edges covered with PVC edge beading. It should be anti-scratch, moisture proof, stain-resistant and dust resistant, termite proof, water-resistant. Metal bases stand All steel components are epoxy powder coated after seven tanks anti corrosion treatment of surface. Laminated wood top. Good standard material. Light Weight easily moved. Colour: light Brown or ivory With swivel caster/wheel for all side movement with lock system.</p> <p>The overall appearance of the product shall be as per photograph. Product should be of reputed brand. As per hotel standard.</p>	4	Pcs
112	B26	Projector complete set with screen and accessories -To be mounted to ceiling for projector.	 <p>Smart Interactive Projector / Digital Teaching Device with</p> <ul style="list-style-type: none"> • CPU - Intel Core i7 	6	Sets

Appendix A

Revised Section 6 for package 0143

			<ul style="list-style-type: none"> • RAM (GB) - 8 • Hard Disk Capacity (GB) - 1000 • OS Compatibility - Windows 10 Professional • VGA Port - Yes • HDMI Port - YES • No. of USB 2.0 Ports (Nos) - 4 • No. of USB 3.0 Ports (Nos) - 2 • Keyboard & Mouse - YES • Central Controller - Available • Board Aspect Ratio - 16: 9 • Touch interface - pen driven. • Touch Technology - Infrared • Ability to integrate cameras in future. • In built Speakers - Yes • Bluetooth connectivity - Yes • Wi-Fi connectivity - Yes • LAN Connectivity - Yes <p>Power Supply V(AC) - 100-240 Projector with Arm - Available Type - Short Throw Technology - DLP Brightness (Lumens) - 3000 & above Projection Lamp - UHP Life of projection Lamp (In normal Mode) - 5000 Hours Cabinet - Wall Mounted lockable enclosure. Air Mouse with Laser Pointer - Available Warranty - 5 Years BID specific OEM authorization. BIS certification of the product</p>		
--	--	--	--	--	--



Appendix A

Revised Section 6 for package 0143

		<p>Enclosure for all the accessories to be provided (Specification: Size H- 34 Inch L- 25.5 Inch W- 11 Inch, MS Cabinet with Lockable facility, a separate lockable tray for Keyboard mouse, Floor stand) Native Resolution: 1280mm x 800mm Graphic Mode: WXGA Weight: 4.80 kg Dimension: 389 mm (W) X 332 mm (D) X 125mm (H)</p> <p>Projected Screen, wall mounted:</p> <p>Motorised Projection Screen - wall mounted with remote control. Dimension: 8 feet X 8 feet Equipped with an Economical Motor with Heat Protection System Infrared Remote Control and Wall Switch Control (UP / STOP / DOWN) High-Quality Matte-White Fabric - Offers clear and vivid pictures. Deluxe Streamline Metal Case - Advanced technic, Easy to Install</p> <p>Smooth and Luxurious Coating - Octagonal Steel case Motorized projector screen with remote control The whole set with installation.</p>		
--	--	--	--	--

Appendix A

Revised Section 6 for package 0143

			 <p>The overall appearance of the product shall be as per photograph. Product should be of reputed brand.</p>		
113	B27	Point-of-sale (POS) Terminal including software	 <p>Including software:</p> <p>The POS system should come with a printer (as shown in the picture) for printing the bills. Do ensure the software is for Training purpose. Also, the card machine should be connected to wifi or Bluetooth for connectivity.</p> <p>Software: Used for taking order, table management, setting menu, taking reservation, generating bills in a F&B outlet.</p> <p>For the training software, vendor will need to program to what is needed. Such as a list of menu items from appetizer, soup, main course, desserts, beverages. What is required for students to train on will be keying in orders, printing of bills, payment of bills – cash credit card, e-payment. Table management – Vendor will need to help program layout of the restaurant with tables and table numbers. Reservation management – able to take guests information and key into the system for reservations.</p>	2	Pc

Appendix A

Revised Section 6 for package 0143

		<p>A restaurant POS system is both the software and hardware restaurants must have the facility to take customers' orders, accept payments, manage food inventory and ultimately manage the entire operation.</p> <p>With printer.</p> <p>Ethernet and Bluetooth connection facility.</p> <p>Bidder will have to mention the reputed make and provide the catalogue.</p> <p>The product of reputed make will only be considered. As approved by the purchaser.</p> <p>The overall appearance of the product shall be as per photograph. Product should be of reputed brand. As per hotel standard.</p>			
114	C2	<p>Trainer's Table</p> <p>-C/w a main switch and a 2-gang, 230V, 13A, socket outlet</p>	 <p>Dimension: L 1050mm x W 600mm x H 750mm Similar or closer to the size. Material: Tabletop made of 25mm thick and base with 18mm thick pre laminated medium density composite (engineered wood) woods boards, laminated. All edges covered with PVC edge beading. It should be anti-scratch, moisture proof, stain-resistant and dust resistant, termite proof, water-resistant. Metal stand All steel components are epoxy powder coated after seven tanks anti corrosion treatment of surface. With modesty panel. Colour: Tabletop White. Metal frame Steel finish. Three drawers: two drawer equal size and last drawer large. Power supply provision on table (2 Switch with twin gang 230V, 6/16 A socket outlet)</p>	2	Pc



Appendix A

Revised Section 6 for package 0143

			<p>Laminated wood top, colour: White</p> <p>The overall appearance of the product shall be as per photograph. Product should be of reputed brand.</p>		
115	C3	Trainer's Chair	 <p>Mesh Butterfly Low Back Chair:</p> <p>Dimension: H: 1000-1100mm, Seat ht: 460-560mm, D-600mm, W-590 mm.</p> <p>Similar or closer to the size.</p> <p>Material: 5-Prong nylon base for stability. Twin Wheel heavy Duty swivel Castor for easy mobility under load. Seat Hot pressed plywood with steel T-Nuts for rigid fastening with PP cover. Back is moulded Bright Bar with stitched Mesh Cloth. Sturdy steel column gas lift for centre support and seat height adjustment. Telescopic ABS cover over steel column. Lockable synchrony tilt mechanism and with Single piece Die castes PP arm rest adjustable with PP pad. Quality tapestry. High density Moulded PU cushion. Upholstery 0.50Mtr.</p> <p>Overall appearance of product as shown in picture. The product must be from a reputed Brand.</p>	2	Pc

Appendix A

Revised Section 6 for package 0143

116	C4	Classroom chair	<div style="text-align: center;">  <p style="font-size: small; text-align: center;">Training Chair with writing tablet, foldable</p> </div> <p>Dimension: W 580 X D 510 X H 830 MM Similar or closer to the size. MATERIAL: MESH & WITH MESH CUSHION, 5-Prong nylon base for stability. Twin Wheel heavy-duty swivel. Castor for easy mobility under load. Seat Hot pressed plywood with steel T-Nuts for rigid fastening with PP cover. Back is moulded. Bright Bar with stitched Mesh Cloth. Quality tapestry. High density Moulded PU cushion. Colour: Will be confirmed at time of purchase. (Provide catalogue) Foldable writing shelve/board: 1 cm thick plywood, anti-Termite, water proof, stain proof, anti-dust, strong material.</p> <p>Overall appearance of product as shown in picture. The product must be from a reputed Brand.</p>	80	Pcs
117	C6	White Board, Wall Mount	<div style="text-align: center;">  </div> <p>Wall – mounted Magnetic Whiteboard (8 feet X 6 feet)</p>	2	Pc

Appendix A

Revised Section 6 for package 0143

			<p>Similar or closer to the size.</p> <p>(i) Features</p> <ul style="list-style-type: none"> • Magnetic Whiteboard: Attach messages, reminders, to-do lists, photos, etc. • Durable & Stain-Resistant Surface: Easy write on and wipe off without stain. • Aluminium Frame: Durable, rust-proof and lightweight. • Rounded PP Caps: Ensures safety and prevent bumps and scratches. • Handy Pen Tray: Perfect for storing marker and keep them close at hand. <p>With installation.</p> <p>Overall appearance of product as shown in picture. The product must be from a reputed Brand.</p>		
118	C7	Wall mounted clock	<div style="text-align: center;">  </div> <p>Colour SILVER</p> <p>Display Type Analog</p> <p>Style Classic</p> <p>Special Feature Alarm</p> <p>Product Dimensions 26W x 26H Centimetres</p>	2	Pc

Appendix A

Revised Section 6 for package 0143

			<p>Similar or closer to the size.</p> <p>Power Source Battery Powered</p> <p>Age Range Adult (Description)</p> <p>Room Type Office, Shop, Living Room, Bedroom</p> <p>Shape Round</p> <hr/> <p>Material of the Frame: Plastic Ideal for offices Durable and Long Lasting: Made Wood, Special and Elegant Design for Home Decor Items. Wall clock with large numerals designed on white face, easy to read quickly. Beautiful and Elegant Design: This Wall Watch modern captures the trend and adds elegance to your Modular Home and wall decoration.</p> <p>Overall appearance of product as shown in picture. The product must be from a reputed Brand.</p>		
119	C8	Extension cords, cables		8	Pc



Appendix A

Revised Section 6 for package 0143

			<p>Power Plate 4 Multiplug Board with 4 Sockets, USB Port, 1.5m Cord, 1500 Watts</p> <p>Type Strip</p> <p>Number of Sockets 4</p> <p>Suitable For Household, Computer, Laptop, TV</p> <p>USB Port Yes</p> <p>Number of USB Ports 1</p> <p>Body And Design Features</p> <p>Socket Material</p> <p>Heavy Duty Brass Connectors</p> <p>Convenience Features</p> <p>Wired</p> <p>Yes</p> <p>Power Features</p> <p>Power Consumption</p> <p>1500 W</p> <p>Dimensions</p> <p>Power Cord Length</p> <p>1.5 m</p> <p>Similar or closer to the size.</p> <p>Overall appearance of product as shown in picture. The product must be from a reputed Brand.</p>		
120	D9	Notice Board		1	Pc

Appendix A

Revised Section 6 for package 0143

			<p>60" x 48" Cork/Dry Erase Combo Board, Magnetic Presentation Whiteboard/Bulletin Combination Board.</p> <p>Board Size: L 5 x W 4 Feet Similar or close to size. Colour: Silver Material: Aluminum Alloy Steel Mounting Type: Wall Mount Frame Material: Aluminum</p> <p>Overall appearance of product as shown in picture. The product must be from a reputed Brand.</p>		
121	D10	Key Box with Cover wall mount	 <p>Metal Key Box: DIMENSION:558X280X52mm SPECIFICATION: 50keys COLOR: Light Grey MEAS:580X400X310mm Weight: 3Kg Similar or close to size.</p> <p>Overall appearance of product as shown in picture. The product must be from a reputed Brand.</p>	1	set
122	D11	Movable White board	 <p>Mobile Magnetic Whiteboard (2440mm X 1220 mm) with Rolling wheels</p>	6	set



Appendix A

Revised Section 6 for package 0143

			<p>Similar or close to size.</p> <ul style="list-style-type: none"> • Magnetic Whiteboard: Attach messages, reminders, to-do lists, photos, etc. • Durable & Stain-Resistant Surface: Easy write on and wipe off without stain. • Aluminium Frame: Durable, rust-proof, and lightweight. • Rounded PP Caps: Ensures safety and prevent bumps and scratches. • Handy Pen Tray: Perfect for storing marker and keep them close at hand. <p>Swivel Wheel with lock system.</p> <p>Overall appearance of product as shown in picture. The product must be from a reputed Brand.</p>		
123	D12	First aid box	<div style="display: flex; align-items: flex-start;">  <ul style="list-style-type: none"> • Compliance with MOM Guidelines • Individually Wrapped Sterile Adhesive Dressing x 20 • Handicrepe Bandage 5cm x 1 • Handicrepe Bandage 10cm x 1 • Absorbent Gauze 10'S x 5 • Hypoallergenic Tape x 1 • Triangular Bandage x 4 • Scissors x 1 • Safety Pin 10'S x 1 • Disposable Glove Pair (Latex) x 2 • Eye Shield x 2 • Eye Pad x 2 • Disposable CPR Kit x 1 • Torch Light x 1 • Water for Injection 5x20ml x 1 </div> <p>Similar or close to the item.</p> <p>Overall appearance of product as shown in picture. The product must be from a reputed Brand.</p>	4	set
124	D13	Flip chart board		6	Set

Appendix A

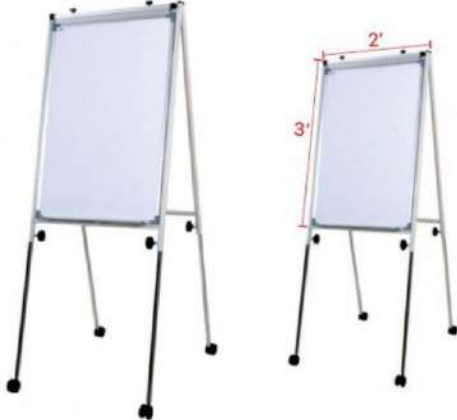
Revised Section 6 for package 0143

			 <p>Conference Flipchart</p> <ul style="list-style-type: none"> • 2' x 3' • With Roller & Magnet • Extra strong twist clamp system suitable for all flipchart papers • Magnetic whiteboard surface • Full length pen-tray for easy access to markers erasers • Telescopic leg for height adjustment • Lockable nylon castors for extra stability & mobility • Easy storage <p>Flip Chart/Conference Flipchart/With Magnetic & Roller size: 2' x 3' / 3' x 4'</p> <p>Similar or close to size.</p> <ul style="list-style-type: none"> • With Roller & Magnet • Extra strong twist clamp system suitable for all flipchart papers • Magnetic whiteboard surface • Special Note: Use Flip charts Paper Pad <p>Detachable board (Can be kept horizontally, if required)</p> <p>Overall appearance of product as shown in picture. The product must be from a reputed Brand.</p>		
125	D14	Warmer	 <p>Warmer Coffee Twin L38xW20cm</p> <p>Similar or close to size.</p> <p>Power: 230V</p>	2	Pcs

Appendix A

Revised Section 6 for package 0143

			<p>Overall appearance of product as shown in picture. The product must be from a reputed Brand. As per hotel standard.</p> <p>CAFERINA SS or equivalent</p>		
126	D15	4-in-1 Laser Printer with duplex unit (with network capability)	<p>4-in-1 multifunction colour laser printer - A4, A3</p> <ul style="list-style-type: none"> - Copy, print, scan resolution: 600 x 600 dpi or higher - Memory: 128MB minimum or better - Parallel or USB connectivity - Compatible with Windows - Duplex printing - Wi Fi Enable <p>Print technology laser. Duplex scanning, Glass platen Ethernet connectivity Multipurpose tray A3 & A4</p> <p>The product must be from a reputed Brand.</p>	2	Pc
127	D16	Printer Table	 <p>Dimintions: 3ft L x 2.2ft W x 1.7 ft H Similar or close to size. Material: Tabletop made of 15mm thick and base with 10mm thick pre laminated Medium density composite (engineered wood) woods boards, laminated. All edges covered with PVC edge beading. It should be anti-scratch, moisture proof, stain-resistant and dust resistant, termite proof, water-resistant.</p>	2	Pcs

Appendix A

Revised Section 6 for package 0143

			<p>With swivel Wheel and Wheel lock system. With cup board system (Two door open system with knob). With removable shelf inside. Capacity: Can carry 250 kg weight.</p> <p>Overall appearance of product as shown in picture. The product must be from a reputed Brand.</p>		
128	D17	<p>Banquet Round Tablecloth Solid Ruffled Spandex Stretch Table Cover Skirt Hotel Restaurant Tablecloth Banquet Round Tablecloth</p>	 <p>Dimensions for 4ft and 6ft round table will be Size:</p> <p>4FT diameter 122cm (1 Pc)</p> <p>6FT diameter 183cm (1 Pc)</p> <p>Made from high-quality spandex stretch material that fits round tables snugly.</p> <p>-Durable and easy to clean, making it the perfect choice for weddings and cocktail parties.</p> <p>-Stretchy fabric ensures that the tablecloth fits without wrinkles or slippage.</p>	2	Pcs







Appendix A

Revised Section 6 for package 0143

			-Versatile enough for use in a variety of settings, including weddings, cocktail parties, and other special events.		
--	--	--	---	--	--







Appendix B

Revised Section 6 for Package-0144

Sr. No.	Item No.	Name of Goods or Related Services (Modified)	Description (Modified)	Quantity (Modified)	UoM (Modified)
			PKG 0144: Training Equipment, Tools & Furniture for setting up of Hotel Operations facility at WSC		
1	A1	Western Cutlery Set	Each set will have:  Spoon Table L21cm  Fork Table L21cm  Knife Table L23cm  Spoon Dessert L19.4cm  Fork Dessert L19.4cm  Knife Dessert L20cm	40	Set

Appendix B

Revised Section 6 for Package-0144

		 <p style="text-align: center;">Tulip Design</p> <p>Fork Fish L18cm</p>  <p style="text-align: center;">Tulip Design</p> <p>Knife Fish L20.7cm</p>  <p style="text-align: center;">Tulip Design</p> <p>Spoon Tea L13.5cm</p>  <p style="text-align: center;">Tulip Design</p> <p>Spoon Soup L17.8cm</p>  <p style="text-align: center;">Tulip Design</p> <p>Knife Butter L18.2cm</p>  <p style="text-align: center;">Tulip Design</p> <p>Knife Steak L22cm</p> <p>All material should be: Stainless steel, Thickness/ Gauge: 18/10 stainless steel with a high-polish finish, food grade, non-toxic, anti-rust, dish washer safe.</p> <p>Similar or close to size</p> <p>The overall appearance of the product shall be as per photograph. The product should be of reputed brand.</p> <p>SS SAFICO, Churchill, Borosil Shri & Sam or Equivalent</p>			
2	A2	Salt & Pepper Mill	Each set contains: One salt container, one pepper container and one tray	8	Set

Appendix B

Revised Section 6 for Package-0144





- Adjustable Ceramic Sea Salt Grinder & Pepper Grinder - Tall Glass Salt and Pepper Shakers - Pepper Mill & Salt (Pack Of 1)
 Material : Glass
 Features : Airtight
 Product Breadth : 10 Cm
 Product Height : 1.5 Cm
 Product Length : 10 Cm
 Net Quantity (N) : Pack Of 1
 HIGH QUALITY STAINLESS STEEL AND GLASS : The salt and pepper grinder is made o

Salt & Pepper mill with good quality wooden tray.
 Salt and Pepper Mills with Beech Stand (2 pcs) - Premium Set of Salt and Peppercorn Grinders with Adjustable Ceramic Coarseness - Brushed Stainless Steel and Glass Body Shakers , (Brown)
 Similar or close to size.
 Material: Durable Glass with metal top, Wood, Stainless Steel, Glass, Ceramic, Metal (matt finish stainless steel, anti rust & food grade)
 ADJUSTABLE & EASY TO USE - Each of these grinders contains an efficient adjustable non-corrosive ceramic grinder so whether one like a fine or coarse grind simply twist to adjust and making it effortless to grind.
 NO MESS AND ELEGANT- The grinding mechanism is on the top of each Salt or Pepper mill so that salt, pepper or spices goes only where one want it and not all over the kitchen table. The refillable set also comes with a handy non-slip space-saver Elegant Beech standing base to ensure they stay where one want them.
 EASY TO FILL - Each individual salt and pepper grinder features a generously sized capacity (without being bulky) 8oz glass reservoir jar (3/4 of a cup) and measures 5.5 inches so one can go longer between refills. When one does need to refill the stainless steel metal top easily screws off easily and has a wide opening ensuring a mess free refill.
 With toughened glass, top-of-the-line ceramic grinder and highest grade brushed stainless steel.

The overall appearance of the product shall be as per photograph. The product should be of reputed brand. Good quality as per hotel standard.



Appendix B

Revised Section 6 for Package-0144

3	A3	Coffee/Teacup (200ml)	 <ul style="list-style-type: none"> ▪ Size (L x W x H) : 108mm x 81mm x 70mm ▪ Capacity: 200ml (approximately) <p>Volume – 200 ml minimum. Similar or close to size. Material: Porcelain, food grade, light weight, chip resistant, scratch resistant, high, lead and cadmium free, environment friendly, gloss finish, dish washer safe. Colour: White Material: Porcelain, dish washer safe, lead-free, non-toxic ceramic, microwave, freezer, and dishwasher safe, stain resistant.</p> <p>The overall appearance of the product shall be as per photograph. The product should be of reputed brand. CHURCHILL, Borosil or equivalent.</p>	30	pc
4	A4	Saucer	 <ul style="list-style-type: none"> ▪ Size (L x W x H) : 153mm x 153mm x 18mm <p>Similar or close to size. Material: Porcelain, food grade, light weight, chip resistant, scratch resistant, high, lead and cadmium free, environment friendly, gloss finish, dish washer safe. For cup size 200ml Colour: White</p>	30	pc



Appendix B

Revised Section 6 for Package-0144

			The overall appearance of the product shall be as per photograph. The product should be of reputed brand. CHURCHILL, Borosil or equivalent.		
5	A5	Coffee/Tea pot (0.6L)	 <p>Colour: White Capacity 600 ml Minimum Similar or close to size. Material: Porcelain, dish washer safe. With handle and lid for keeping tea hot, lead-free, non-toxic ceramic, microwave, freezer, and dishwasher safe, stain resistant.</p> <p>The overall appearance of the product shall be as per photograph. The product should be of reputed brand. CHURCHILL, Borosil or equivalent.</p>	8	pc
6	A6	Main Course plate (12 inches)	 <p>Size (L x W x H) : 267mm x 267mm x 26mm Similar or close to size. Material: Porcelain and should be dish washer safe, lead-free, non-toxic ceramic, microwave, freezer, and dishwasher safe, stain resistant. Colour: Ivory white</p>	30	Pc



Appendix B

Revised Section 6 for Package-0144

			<p>The overall appearance of the product shall be as per photograph. The product should be of reputed brand.</p> <p>CHURCHILL, Borosil, or Equivalent.</p>		
7	A7	Salad plate (8 inches)	 <p>Dimension: 8 inches Dia Thickness: 4 mm minimum Material: Porcelain and should be dish washer safe, lead-free, non-toxic ceramic, microwave, freezer, and dishwasher safe, stain resistant. Colour: Ivory white</p> <p>The overall appearance of the product shall be as per photograph. The product should be of reputed. CHURCHILL, Borosil, or Equivalent.</p>	30	Pc
8	A8	Side plate (6 inches)	 <p>Dimension: 6 inches Dia. Thickness: 4mm minimum Similar or close to size. Material: Porcelain, dish washer safe, lead-free, non-toxic ceramic, microwave, freezer, and dishwasher safe, stain resistant. Colour: Ivory white</p>	30	Pc



Appendix B

Revised Section 6 for Package-0144

			<p>The overall appearance of the product shall be as per photograph. The product should be of reputed brand. As per hotel standard.</p> <p>CHURCHILL, Borosil or Equivalent</p>		
9	A9	Soup bowl	 <p>Non-of the crockery catalogue provide the thickness of Bowl. L 123 x W 106 x H59mm. Volume 270ml</p> <p>Dimension: Depth 4 inch, Thickness:4 mm minimum Capacity: 280 ml minimum Similar or close to size. Material: Porcelain, dish washer safe, lead-free, non-toxic ceramic, microwave, freezer, and dishwasher safe, stain resistant. Colour: white</p> <p>The overall appearance of the product shall be as per photograph. The product should be of reputed brand. As per hotel standard. CHURCHILL, Borosil or Equivalent</p>	30	Pc
10	A10	Packet sugar holder	 <p>Tea Coffee & Sugar Container:</p> <p>Size: 9X6.5X4.5Cm</p> <p>Capacity: 200 ml minimum (White) Thickness: 4mm minimum Similar or close to size.</p>	8	Pc

Appendix B

Revised Section 6 for Package-0144

			<p>Material: Ceramic, dish washer safe, lead-free, non-toxic ceramic, microwave, freezer, and dishwasher safe, stain resistant.</p> <p>The overall appearance of the product shall be as per photograph. The product should be of reputed brand. As per hotel standard.</p> <p>CHURCHILL, Borosil or Equivalent</p>						
11	A11	Demi-tasse set	<div style="text-align: center;">  </div> <p>ESPRESSO CUP and Saucer: Each set contains: One cup and one saucer (Should fit the cup).</p> <p>Dimensions:</p> <table border="1" style="width: 100%; border-collapse: collapse;"> <tr> <td style="padding: 2px;">↳ Cup</td> <td style="padding: 2px;">Length 8.5cm, Width 6.5cm, Height 5.5cm</td> </tr> <tr> <td style="padding: 2px;">↳ Saucer</td> <td style="padding: 2px;">Diameter 11.5cm, Height 2cm</td> </tr> </table> <p>Colour: White Capacity: Cup: 70 ml Similar or close to size. Material: Porcelain, dish washer safe, lead-free, non-toxic ceramic, microwave, freezer, and dishwasher safe, stain resistant.</p> <p>The overall appearance of the product shall be as per photograph. The product should be of reputed brand. As per hotel standard.</p> <p>CHURCHILL, Borosil or equivalent.</p>	↳ Cup	Length 8.5cm, Width 6.5cm, Height 5.5cm	↳ Saucer	Diameter 11.5cm, Height 2cm	5	Set
↳ Cup	Length 8.5cm, Width 6.5cm, Height 5.5cm								
↳ Saucer	Diameter 11.5cm, Height 2cm								
12	A12	Creamer jug	<div style="text-align: center;">  </div>	8	Pc				



Appendix B

Revised Section 6 for Package-0144

			<p>Height: 12 cm (4 ¾ ") Volume: 39 cl (13 oz)</p> <p>Dimension: 39 cl (13 oz) Thickness: 4mm minimum Similar or close to size. Material: Ceramic, dish washer safe, lead-free, non-toxic ceramic, microwave, freezer, and dishwasher safe, stain resistant. Humanized Design: Drip-free spout; Comfort-grip handle for easy pouring and cleanliness. The overall appearance of the product shall be as per photograph. The product should be of reputed brand. As per hotel standard. CHURCHILL, Borosil or equivalent.</p>		
13	A13	Platter service equipment	<p style="text-align: center;">STAINLESS STEEL</p>  <p>Different sizes: as shown in the picture. All material should be: 304 Stainless steel, food grade, non-toxic, anti-rust, dish washer safe. The overall appearance of the product shall be as per photograph. The product should be of reputed brand. As per hotel standard.</p>	4	Set



Appendix B

Revised Section 6 for Package-0144

			SS SAFICO, Borosil, Shri & Sam or Equivalent		
14	A14	Wine decanter	 <p>Dimension: Height: 22.4cm Minimum Diameter: 22.4cm Minimum Capacity: 1000 ml (Suitable for 1 regular size wine bottle)</p> <p>Similar or close to size. Material: Glass (sturdy) The overall appearance of the product shall be as per photograph. The product should be of reputed brand. As per hotel standard. CHURCHILL, Borosil or equivalent.</p>	2	Pc
15	A15	Classical wine glasses	 <p>MD 98mm / H 224mm</p> <p>Capacity: 230ml Similar or close to size. Material: Glass, transparent. The overall appearance of the product shall be as per photograph. The product should be of reputed brand. As per hotel standard Ocean, Borosil or equivalent.</p>	30	Pc



Appendix B

Revised Section 6 for Package-0144

16	A16	High ball juices glasses	 <p>Tumbler Hi Ball: Dimension: Ø 60 x H 165 mm Capacity: 320ml Similar or close to size Material: Glass, transparent, dish washer safe. The overall appearance of the product shall be as per photograph. The product should be of reputed brand. As per hotel standard Ocean, Borosil or equivalent.</p>	40	Pc
17	A17	Rock glasses	 <p>Glass Rock: Dimension: 30cl Ø7.5 x H 9 cm Similar or close to size Material: Glass, transparent, dish washer safe. The overall appearance of the product shall be as per photograph. The product should be of reputed brand. As per hotel standard Ocean, Borosil or equivalent.</p>	20	Pc
18	A18	Martini glasses		6	Pc



Appendix B

Revised Section 6 for Package-0144

			<p>DIMENSIONS</p> <p>Width 11.2 cm Depth 11.2 cm Height 18.3 cm Capacity 21 cl</p> <p>Similar or close to size Material: Glass, transparent, dish washer safe. The overall appearance of the product shall be as per photograph. The product should be of reputed brand. As per hotel standard Ocean, Borosil or equivalent.</p>		
19	A19	Sherry/ port	 <p>Sherry & Port Glass Perception 122ml</p> <p>Capacity: 122 ml or close to that Similar or close to size Material: Glass, transparent, dish washer safe. The overall appearance of the product shall be as per photograph. The product should be of reputed brand. As per hotel standard Ocean, Borosil or equivalent.</p>	6	Pc
20	A20	Multi-purpose wine glass		30	Pc



Appendix B

Revised Section 6 for Package-0144

			<ul style="list-style-type: none"> • Dimensions: 8.1 x H16.7cm • Capacity: 13oz <p>Similar or close to size Material: Glass, transparent, dish washer safe. The overall appearance of the product shall be as per photograph. The product should be of reputed brand. As per hotel standard Ocean, Borosil or equivalent.</p>		
21	A21	Champagne glasses	 <p>Capacity: 210 ml Similar or close to size Material: Glass, transparent, dish washer safe. The overall appearance of the product shall be as per photograph. The product should be of reputed brand. As per hotel standard. Ocean, Borosil or equivalent.</p>	30	Pc
22	A22	Shooter glasses	 <p>Capacity: 50ml Similar or close to size</p>	12	Pc

Appendix B

Revised Section 6 for Package-0144

			<p>Material: Glass, transparent, dish washer safe. The overall appearance of the product shall be as per photograph. The product should be of reputed brand. As per hotel standard. Ocean, Borosil or equivalent.</p>		
23	A23	Margarita coupe	 <p>Capacity: 330ml Similar or close to size Material: Glass, transparent, dish washer safe. The overall appearance of the product shall be as per photograph. The product should be of reputed brand. As per hotel standard. Ocean, Borosil or equivalent.</p>	6	Pc
24	A24	Water pitcher	 <p>Capacity: 1.9 L Similar or close to size. Design: With half cover with steel handle. Material should be: 304 Stainless steel or cromargan, food grade, non-toxic, anti-rust, dish washer safe.</p> <p>The overall appearance of the product shall be as per photograph. The product should be of reputed brand. As per hotel standard.</p>	4	Pc

Appendix B

Revised Section 6 for Package-0144

			SS SAFICO, Shri & Sam or Equivalent		
25	A25	Wine bottle floor corker	 <p>The Wine Bottle Floor Corker makes bottling wine easy. Procedure should be: simply add a cork, push the lever. The spring-loaded lever instantly gives a perfectly corked bottle. Each of the 3 corker legs include holes for mounting or securing to the floor (installation hardware not included). The floor corker is super lightweight but constructed of rolled steel and hard plastic materials. There are no flimsy joints or rivets, even when exerting pressure while corking. All standard 750mL bottles can be used with a variety of cork sizes including #7, #8, and #9. Since the plunger depth is adjustable, it also works with the Belgian beer bottle corks, champagne bottles with wine corks, and synthetic plastic corks.</p> <p>Easy to Use: like when a cork added to this Wine Bottle Floor Corker, push down on the lever, and the cork goes into the bottle with ease. Durable: Rolled steel construction with plastic handle Comfortable Grip: Fit-moulded plastic red handle for a firm grip Versatile: Works with all straight #7, #8, and #9 size corks; includes adjustable plunger depth Material: Metal with colour coat (Portuguese-Red)</p> <p>Similar or close to size (Standard size)</p> <p>The overall appearance of the product shall be as per photograph. Product should be of reputed brand. As per hotel standard.</p>	2	Set



Appendix B

Revised Section 6 for Package-0144

26	A26	Bartender set	 <p>Each set contains: 14-Pieces minimum:</p> <p>Cocktail rustproof Shaker SS with Mixing Glass 24oz. 30/60ml Stainless Steel Cocktail Jigger and 15/30ml Stainless steel jigger (2 x Double-sided Jigger) Strainer SS (Hawthorne strainer) Mixer Spoon SS Tongs SS Pourer SS (2 x Liquor Pourers) Muddler (Mojito Muddler) Double lever corkscrew Stoppers (2 x Stoppers) Bottle Opener With an Acrylic wood stand or equivalent Material: 304 Stainless Steel Use: Bar, Hotel, Family</p> <p>This shaker set should made up of food-grade 304 stainless steel and is completely safe to use. Heavy-duty and high-grade martini shaker cocktail set. This entire bar accessories kit should made up of stainless-steel alloy SS304. It must be all dishwasher compatible.</p> <p>The overall appearance of the product shall be as per photograph. The products should be of reputed brand. As per hotel standard.</p>	8	Set
----	-----	---------------	---	---	-----



Appendix B

Revised Section 6 for Package-0144

27	A27	Bar knife and zester set	 <p>Each set contains: 2 different pieces in one set (Refer picture): Dimensions: knife length: 8.7" (22 cm) zester length: 6.7" (17 cm) Material: 304 stainless steel blade, wood and brass handle Similar or close to size. Material: High carbon 304 stainless steel blade with durable triple-rivet wooden handle. Dishwasher safe, food grade and non-toxic, anti-rust. Colour: Steel blade and wooden handle.</p> <p>The overall appearance of the product shall be as per photograph. Product should be of reputed brand. As per hotel standard.</p>	4	Set
28	A28	Bar cutting Board 6"x10"	 <p>Acrylic Cutting Chopping Board: Dimension: L 15 inches x W 10 inches, similar or close to size. Material: Acrylic, food grade and non-toxic, dishwasher safe Colour: White</p> <p>The overall appearance of the product shall be as per photograph. Product should be of reputed brand. As per hotel standard.</p>	4	Pc

Appendix B

Revised Section 6 for Package-0144

29	A29	Bar garnish compartment (6 compartment unit)	 <p>6 Compartment Garnish Condiment Tray: Each set contains: 6 removable compartments and a box with transparent lid. Dimension: Box: L 19.5 inches x W 6 inches x H 3.5 inches Compartment: L 5.5 inches x W 2.9 inches x H 2.7 inches. Similar or close to size. Material: Food grade plastic, non-toxic, transparent cover box With six removable compartments made up of food grade durable plastic. Dish washer safe. Colour: Black box, transparent lid with white compartments or equivalent. The overall appearance of the product shall be as per photograph. The products should be of reputed brand. As per hotel standard.</p>	2	Set
30	A30	Wine opener	 <p>Wine bottle opener. Dimension: The size of this wine corkscrew after folding is 4.69 inches * 1.1 inches. Similar or close to size. Material: Sturdy Stainless Steel with wooden handle. Finish Type: Steel polished. Item Weight: 90 Grams approx. Materials: The wine opener is made of food-grade stainless steel with a handle inlaid with natural wood. Product include: The bottle opener fold up is an all-in-one type, includes multiple functions. It can open wine corks, beer lids, and can also be used to cut foil.</p>	20	Pc



Appendix B

Revised Section 6 for Package-0144

			The overall appearance of the product shall be as per photograph. The products should be of reputed brand. As per hotel standard.		
31	A31	Restaurant wood side table (3 tier)	 <p>Dimension: D 16" x W 32" x H 33" Similar or closer to the size. Shape: Rectangular Handle at both sides, for easy movement from all sides. Side encloses, at least 3 inches and frame with powder coated cast iron or equivalent material. 3 horizontal shelves, at equal division, adjustable, carbon coloured, 4 swivel castors, 4 smooth running wheels (picture shows wheels with brass caps, Swivel wheel/caster, noise free with lock system). Material: 304 stainless steel, 3 shelves made of acid-resistant laminate, anti-scratch, moisture proof, stain-resistant and dust resistant, termite proof, water-resistant, and rustproof. with solid wood frame. Use: Hotel Trolley, Commercial Furniture. Can carry 150 kg weight minimum.</p> <p>The overall appearance of the product shall be as per photograph. Product should be of reputed brand. As per hotel standard.</p>	2	Pc



Appendix B

Revised Section 6 for Package-0144

32	A32	Wine bucket with stand	<div style="display: flex; align-items: flex-start;"> <div style="flex: 1;"> <p>WINE BUCKET, 9-3/8" L, 8" W., 8-3/8" H., HAMMERED, STAINLESS STEEL</p> <p>WINE BUCKET STAND, 24" H., STAINLESS STEEL</p> <p>WINE BUCKET STAND, 24" H., BLACK WROUGHT IRON</p> </div> <div style="flex: 2; text-align: center;">  </div> </div> <p>Bucket: Dimension: Opening Diameter : 20 x 20 Centimetres, Height : 22 Centimetres. Similar or close to size. Material: Hammered 304 stainless steel, food grade, non-toxic, anti-rust, dish washer safe. Colour: Steel finish. Bucket must have comfortable holder at both sides, of same material.</p> <p>Bucket stand: Foldable: Dimension: Overall Height: 70 Centimeters / 27.50 Inches (Approx). Similar or close to size. Material: 304 Stainless steel, food grade, non-toxic, anti-rust, dish washer safe. Colour: Steel finish. Must be stable when bucket is placed on it with 20 kg weight minimum. The overall appearance of the product shall be as per photograph. Product should be of reputed brand. As per-hotel standard.</p>	2	Set
33	A33	Bar service flexi-mat	<div style="text-align: center;">  </div> <p>Pic- 1</p>	10	Set



Appendix B

Revised Section 6 for Package-0144

			 <p>Pic-2</p> <p>Each set contains: 2 Sizes - 1 Pcs each size: First picture - Mat Service BI W 12 x L18 inches. Thickness: 1.5 cm 2nd picture - Mat Bar BI L 60 x W 8 cm Thickness: 1.8 cm Similar or close to size. Material: Rubber Colour: Black The overall appearance of the product shall be as per photograph. The products should be of reputed brand. As per-hotel standard.</p>		
34	A34	Ice scoop	 <p>Polished Stainless Steel Ice Scoop: Dimensions – W 80mm x L 220mm x H 55mm Capacity – 12oz Similar or close to size. Material: 304 Stainless steel, food grade, non-toxic, anti-rust, dish washer safe. With steel handle.</p> <p>The overall appearance of the product shall be as per photograph. The products should be of reputed brand. As per hotel standard. SS SAFICO, Shri & Sam, or Equivalent IS</p>	4	Pc



Appendix B

Revised Section 6 for Package-0144

35	A35	Ice Cooler Box (60 Litre)	 <p>Capacity 60 L Similar or close to size. Colour: White or any pestle colour. With well fit cap, with handle, vent lid, tap & wheels. Double insulated The overall appearance of the product shall be as per photograph. The products should be of reputed brand. As per hotel standard.</p>	2	Pc
36	A36	Waiter tray	 <p>Tray Round Brown: Dimension: 14" Dia Similar or close to size. Material: Food grade durable hard wearing melamine, ensuring a durable finish to resist wear and tear, unbreakable, non-toxic, dish washer safe. Nonslip tray. Colour: Dark brown/ Black</p> <p>The overall appearance of the product shall be as per photograph. Product should be of reputed brand. As per hotel standard.</p>	20	Pc

Appendix B

Revised Section 6 for Package-0144

37	A37	Salad Services Gear	 <p>Dimension: 11 inches. Similar or close to size. Material: 304 Stainless steel, food grade, non-toxic, anti-rust, dish washer safe. With steel handle. With clip clamp single tooth.</p> <p>The overall appearance of the product shall be as per photograph. The products should be of reputed brand. As per hotel standard. SS SAFICO, Shri & Sam, or Equivalent IS</p>	4	Pc
38	A38	Chafing Dish Set		4	Set

Appendix B

Revised Section 6 for Package-0144



HAPES STAINLESS STEEL RECTANGULAR FULL GLASS LID CHAFFING DISH: With drain outlet and drain cap.
The chaffing dish also has handles to ensure that the product can be moved with ease.

Specifications:

Overall Dimensions: L 23.6 x W 14.6 x H 11.4"

Frame Height: 7.9"

Alcohol Furnace Height: 2.4"

Similar or close to size.

Material: Food Grade 304 Stainless Steel and glass (durable), food grade, non toxic, anti rust, dish washer safe.

Volume: 9 L / 8 Quart

Colour: Silver

Shape: Rectangle

Can Serve: at Least 8 People (Single)

Package Includes (for Single Buffet Stove):

1 x Folding Frame. (The frame must include a bottom tray which supports 2 fuel holders to store fuels for heating food)

1 x Cover

1 x Cover Handle

1 x Water Pans

1 x 1/2 + 2 x 1/4 Food pans (Only half+1/4 Size). – 2 sets

2 x 1/2 size pans (Only half size pans). – 2 sets

Highlighted in the picture above.

2 x Fuel Holders

Appendix B

Revised Section 6 for Package-0144

			Capacity: 8 Quarts (Similar or close to capacity). The overall appearance of the product shall be as per photograph. Product should be of reputed brand. As per hotel standard.		
39	A39	Coffee Cloths for Espresso Machine	 <p>Dimension: L 12" x W 12", Similar or close to size. Material - Microfiber cloth, cotton. Colour: Various Colours. The overall appearance of the product shall be as per photograph. Product should be of reputed brand. As per hotel standard.</p>	20	Pc
40	A40	Electric kettle	<p>Thick see through borosilicate glass body.</p> <p>concealed heating element for easy cleaning automatically turns off when water finishes boiling. dry boil protection - the kettle cannot be switched on when there is no water inside. double protection controller high quality thermostat for quick and safe boiling spout with filter. lid release button. led light indicator. easy to open, fill and close hinge lid. 360 rotating bases for ease of use cord winder for easy storage. overheat safety protection in cool touch electric kettle. longer power cord with 360 cord swivels 100 % copper wire conductor in power cord 1 year warranty on borosil electric glass kettle, 1.8l Must contents:</p> <p>1 appliance set. 1 user manual electric glass kettle, 1.8l</p>	2	Pc



Appendix B

Revised Section 6 for Package-0144

			<p>Similar or close to size</p> <p>capacity: 1.8l (6 cups) net weight: 990g power: 1500w voltage: 230v ac / 50 hz power cord: 1.2 m long, 3 pin 3 cores. product dimensions: 22.5cm x 16cm x 24cm Similar or close to dimension</p> <p>Steel finish Electric Glass Kettle 1500 W Capacity: 1.8 litter The overall appearance of the product shall be as per photograph. Product should be of reputed brand. As per hotel standard.</p>		
41	A41	Coffee Bean Storing Tins	 <p>Capacity: Minimum 1.8 litres Similar or close to capacity. Material: 304 stainless steels with a glass window, airtight container. Food grade, non-toxic, anti-rust, dish washer safe. Colour: Steel Gray</p> <p>The overall appearance of the product shall be as per photograph. Product should be of reputed brand. As per hotel standard.</p>	4	Pc

Appendix B

Revised Section 6 for Package-0144

42	A42	Room Service Tray	 <p>Large Serving Tray, Tray with Cutout Handles:</p> <p>Dimensions: L 40 x W 27 x H 5 Centimetres Similar or close to size. Shape: Rectangular Material: Wood Colour: Brown</p> <p>The overall appearance of the product shall be as per photograph. Product should be of reputed brand. As per hotel standard.</p>	10	Pc
43	A43	Coffee Machines (Manual)	 <p>LCC- PID controlled temperature. This machine must have a Stainless-Steel body & comes with a commercial 58 mm group.</p> <p>Watertank: 2,5 l Coffee/water/steam pump:15 bar Dimensions LxDxH:22,5x27x38 cm Boiler heating element:1200W Voltage:230V 50Hz – 120V 60Hz Weight:9,2 kg approx.</p> <p>Accessories delivered with LELIT58 2-ways filter holder with design handle and coffee slide spout LELIT58 1 dose filter (7-9 g)</p>	6	Set

Appendix B

Revised Section 6 for Package-0144

		<p>LELIT58 2 doses filter (14-18 g) IMS / LELIT58 blind filter Spoon for coffee powder 35l water softener filter.</p> <p>LCC PID controls with Hi-res OLED Display</p> <p>Precision IMS Baskets</p> <p>Programmable Pre-Infusion, standby & Washing cycle.</p> <p>Wide Cup warmer.</p> <p>Stainless steel water tray grate</p> <p>Espresso cup rack</p> <p>Backlit Stainless-Steel switches.</p> <p>Multidirectional Steam / Hot Water wand.</p> <p>Backlit Manometer to measure the coffee pressure.</p> <p>Brushed Stainless steel appliance body.</p> <p>Graphical Display for lack of water</p> <p>3-way solenoid valve to dry up the coffee powder</p> <p>300 ml brass coffee boiler- single boiler dual use</p>		
--	--	--	--	--



Appendix B

Revised Section 6 for Package-0144

			<p>Commercial 58 mm group.</p> <p>58 mm filter holder with ergonomical handle and exclusive coffee slide.</p> <p>delivered with 1 cup & 2 cup filters & blind filters (all Precision IMS) & 35 litre Water Softener</p> <p>Similar or close to size.</p> <p>The overall appearance of the product shall be as per photograph. Product should be of reputed brand. As per hotel standard.</p>		
44	A44	Coffee Bean Grinder	 <p>Coffee grinder: Dimensions (wxdxh) (mm): 210 x 384 x 559 Electrical power (W): 550 W Grinding capacity (G/S): 3 Compartment capacity (G): 1100 Grinding disc diameter (mm): 64 Blade material: Titanium-coated stainless steel (4 times more durable than standard blenders) Touch screen. Weight (kg): 13 Technology that automatically makes any necessary grinding and dosing corrections to ensure precise and consistent dispensing without any direct intervention from the counter. It should come with all accessories.</p>	3	Set

Appendix B

Revised Section 6 for Package-0144

			<p>Precision grinding so the coffee must grind straight into the filter holder, leaving no stray particles. The dispensing process should be accompanied by an illuminating light, ensuring a well-lit and clear working area.</p> <p>With adjust preferences each time or set them once and for all. Few simple taps on the intuitive display, one can easily configure the grind size and time.</p> <p>The overall appearance of the product shall be as per photograph. Product should be of reputed brand. As per hotel standard.</p>		
45	A45	Milk Frothing Pitcher (600ml)	 <p>Milk Pitcher: Capacity: 600 Milliliters Similar or close to capacity. Material: Stainless Steel Colour: silver All material should be: Stainless steel, food grade, non toxic, anti rust, dish washer safe.</p> <p>The overall appearance of the product shall be as per photograph. Product should be of reputed brand. As per hotel standard. SS SAFICO, Borocil, Shri & Sam or Equivalent</p>	12	Pc
46	A46	Milk thermometer	 <p>... -10+100°C, 0+220°F</p>	6	Pc

Appendix B

Revised Section 6 for Package-0144

			Thermometer Milk Compact Designer.		
47	A47	White linen square tablecloth	 <p>Measurement: L 68" x W 68" Similar or close to size. Material: Linen 100%, Side stitched, machine washable, reusable. The overall appearance of the product shall be as per photograph. Product should be of reputed brand. As per hotel standard.</p>	12	Pc
48	A48	White linen napkin 20"x20"	 <p>20"x20" Similar or close to size. Material: Linen 100%, Side stitched, machine washable, reusable. The overall appearance of the product shall be as per photograph. Product should be of reputed brand. As per hotel standard.</p>	48	Pc
49	A49	Apron with Pocket	 <p>Dimension: Standard size Material: Cotton 100% Colour: Navy Blue</p>	22	Pc

Appendix B

Revised Section 6 for Package-0144

			The overall appearance of the product shall be as per photograph. Product should be of reputed brand. As per hotel standard.		
50	B2	LED TVs (50")	<p>1.25 m QN90C Neo QLED 4K Smart TV Neo QLED 4K HDR+ with 60W Sound* (In Sizes 55 or above) (QN90C) 50"</p> <p>Similar or close to size.</p> <p>The overall appearance of the product shall be as per photograph. Product should be of reputed brand. As per hotel standard.</p>	2	Sets
51	B4	Refrigerator door) (2	 <p>Key Features: Dimension: D 77 x W 79 x H 185.5 Centimeters Similar or close to size. Capacity: 530 litres Configuration: Freezer-on-Top Capacity - 530 Litres Defrosting Technology: Frost Free Refrigerator Type - Double Door Colour: Silver Refrigerator Fresh Food Capacity: 404 litres Freezer Capacity: 126 Litres Installation Type: Freestanding Form Factor: Convertible Special Features: Inverter Compressor Colour: Real Stainless Voltage: 220 Volts Wattage: 50 Watts Number of Racks: 3</p>	1	Set

Appendix B

Revised Section 6 for Package-0144

			<p>Number of Drawers: 2 Defrost System: Frost Free Door Orientation: Left Door Material: Stainless Steel Shelf Type: Toughened Glass Number of Shelves: 3 Included Components: 1 Refrigerator Unit, 1 User Manual, Warranty Card.</p> <p>The overall appearance of the product shall be as per photograph. Product should be of reputed brand. As per hotel standard. Samsung, LG, Whirlpool or equivalent</p>		
52	B5	Chair	 <p>Material: Upholstered Fabric with Wooden Legs. Colour: Will be finalize at the time of purchase by the purchaser. Good quality wood stand with good quality cushion</p> <p>Capacity: Must be able carry weight of 200 kg minimum.</p> <p>The overall appearance of the product shall be as per photograph. Product should be of reputed brand. As per hotel standard.</p> <p>Provide catalogue to the purchaser.</p>	24	Pc

Appendix B

Revised Section 6 for Package-0144

53	B6	Table	 <p>Dimension: H 76 cm x D 80 cm x L 80cm Similar or closer to the size. Material: Medium density composite (engineered wood) woods boards. laminated top and back. Frame made of 1.2 mm thick M.S. cold rolled close annealed tube duly powder coated/ chrome plated or equivalent material. Fitted with 25mm Pre-laminated Board top. All edges covered with PVC edge beading.</p> <p>It should be anti-scratch, moisture proof, stain-resistant and dust resistant, termite proof, water-resistant, and rustproof. Closed back with a high-quality wood laminated material.</p> <p>Colour: Ivory or equivalent</p> <p>Metal base stand All steel components are epoxy powder coated after seven tanks anti corrosion treatment of surface.</p> <p>Light Weight easily moved.</p> <p>Capacity: Must be able carry weight of 200 kg minimum.</p> <p>The overall appearance of the product shall be as per photograph. Product should be of reputed brand. As per hotel standard.</p>	6	Pc
54	A1	Computer system complete with application software	<p>Computer system All in One Core i7 (16 GB DDR4/1 TB SSD/Windows 11 Pro 64 bit/23.8 Inch Screen) System Features Cache Memory: 12 MB Processor Name: Core i7</p>	2	Set

Appendix B

Revised Section 6 for Package-0144

			<p>Processor Brand: Intel Operating System: Windows 11 Pro Processor Model: Intel® Core i7 Memory Expandable Memory: 32 GB Memory Slots: 2 System Memory: 16 GB DDR4 Memory Detail: 16GB DDR4 Display Touchscreen Support: No Display Size: 27 inch Full HD: Yes 3D Support: No Display Resolution: 1920 x 1080 Display Type 27-inch FHD (1920 x 1080)</p> <p>Other Display features</p> <p>Integrated Graphic Processor Intel® Iris® Xe Graphics/Intel HG Webcam 1080p with microphone Built-in Webcam</p> <p>Storage SSD Capacity: 1 TB Audio: Built-in Microphone Speaker Output: Yes Connectivity: Memory Stick Slot 1 SD-card slot: VGA</p>		
--	--	--	---	--	--

Appendix B

Revised Section 6 for Package-0144

			<p>USB: 1 USB 3.1 Gen 1 port with Power on/Wake-up support, 2 USB 3.1 Gen 1 ports, 1 USB 3.1 Gen 2 port with PowerShare, 1 USB 3.2 Type-C Gen 2 port</p> <p>Bluetooth: Bluetooth 5.2</p> <p>Headphone Jack: 3.5mm</p> <p>HDMI: Yes</p> <p>Memory Card Reader: yes</p> <p>Microphone Jack: Yes</p> <p>Network: Wireless: Wi-Fi 6E AC/AX</p> <p>Input Devices</p> <p>Mouse: Wired Mouse US English</p> <p>Keyboard: Wired Keyboard</p> <p>- 3-year warranty</p> <p>- With security cable lock</p>		
55	A2	4-in-1 Laser Printer with duplex unit (with network capability)	<p>4-in-1 multifunction colour laser printer - A4, A3</p> <ul style="list-style-type: none"> - Copy, print, scan resolution: 600 x 600 dpi or higher - Memory: 128MB minimum or better - Parallel or USB connectivity - Compatible with Windows - Duplex printing - Wi Fi Enable <p>Print technology laser</p> <p>Duplex scanning, Glass platen</p> <p>Ethernet connectivity</p> <p>Multipurpose tray A3 & A4</p> <p>Full set</p>	2	Pc

Appendix B

Revised Section 6 for Package-0144

56	A3	Property Management System	<p>Hospitality OPERA Cloud Property Management – for Education training</p> <p>With 100 mock up rooms on the training system. Must have 4-6 schemas for training. Or equivalent.</p> <p>Functions:</p> <p>A property management system (PMS) is a core part of a hotel's technology stack that automates administrative tasks, including reservations, guest profiles, billing, and room statuses. A hotel PMS should include the following features:</p> <p>Front-desk operations</p> <p>Check in, check out.</p> <p>Hotel reservations</p> <p>Cashring</p> <p>Back-office management</p> <p>Housekeeping</p> <p>Centralized booking system</p> <p>Subscription based: Cloud based SaaS</p>	1	System
57	B2	High Chairs	 <p>Dimension: D 42 x W 42 x H 84 Centimeters</p>	3	Pc

Appendix B

Revised Section 6 for Package-0144

			<p>Colour: BLACK Frame Material: Metal Furniture Finish: Black Seat Height: 32 Inches Seat Width: 13 Inches Optimal comfort: Covered with high-quality soft PU, durable and comfortable; ergonomic seat and circular footrest. Adjustable & swivel: Rotatable cylinder with height adjustment allows to adjust the stool from counter to bar height (22. 4" - 32. 3"); this bar stool features 360° swivel design. Floor protection: Silicon anti-slip pads on the bottom prevent the bar stool from slippery while protecting your floor from scratches. Product Size: Seat size- (L - 14.5" Inches) x (W - 13" Inches), Seating Height- Adjustable From 22" to 32" Inches, Overall Height at Full 36" Inches. Product Care: Wipe with damp cloth Recommend adjustable high chair for front desk. Similar or close to size. The overall appearance of the product shall be as per photograph. Product should be of reputed brand.</p>		
58	A1	Computer system	<p>PC Workstation (All-in-One)</p> <ul style="list-style-type: none"> • Processor Make 12th Generation Intel Core i5 processor or Higher • Processor Description Intel Core i5-1235U (1.0 GHz to 4.4 GHz with Intel Turbo Boost Technology, 12 MB L3 Cache, 10 Cores, 12 threads) or Higher • Operating System & Software Pre - loaded Windows 11 Professional • Memory & Storage 16GB DDR4-3200 MHz RAM (1 x 16 GB) SSD 512 GB Expansion Slots: 2 M.2 (1 for SSD, 1 for WLAN) 16 GB DDR4- Memory expandability up to 32 GB with 2 DIMM Slots or Higher • Graphics & Networking Intel Graphics/Integrated Gigabit 10/100/1000 Ethernet Controller Intel Graphics / Integrated (802.11aX) 2x2 Wi-Fi & Bluetooth 5.0 	82	Nos.



Appendix B

Revised Section 6 for Package-0144

			<ul style="list-style-type: none"> • Graphics Integrated Intel UHD Graphics • Webcam Integrated 5 MP Privacy Camera with Dual array microphone or higher • Audio Features Dual 2 W speakers or higher • Ports and Connectors Video: 1 HDMI, USB: 4 (2 USB 3.1 Gen 1, 2 USB 2.0), 2 M.2 PCIe for WLAN & Storage, 1 port, 1 Internal Bay, 1 Headphone / microphone combo, 1RJ 45 • Hardware Security lock slot Standard security lock slot • Power Supply 65-90 W with 88% average efficiency or better • Windows Certification Microsoft Windows FCC, CE, RoHS, UL, EPEAT, ISO 9001, 14001, 20001, 27001 Certificates • Manageability Integrated utility to enables hardware level testing outside the operating system & Drivers should be available on OEM Website for download. • Energy Efficiency Compliance EPEAT registered. • Wired Keyboard Keyboard; Wired Optical Mouse • Monitor 23.8" IPS, antiglare with Minimum resolution of 1920x1080, 16:9 aspect ratio, 1000:1 Contrast ration, 250 nits brightness, viewing angle of 178/178 or Higher 3 Years of Onsite Warranty 		
59	A4	Projected Screen, wall mounted	<p>Motorised Projection Screen - wall mounted with remote control. Dimension: W 8 feet X H 8 feet (Minimum)</p> <ul style="list-style-type: none"> • Equipped with an Economical Motor with Heat Protection System • Infrared Remote Control and Wall Switch Control (UP / STOP / DOWN) 	3	Pc

Appendix B

Revised Section 6 for Package-0144

			<ul style="list-style-type: none"> • High-Quality Matte-White Fabric - Offers clear and vivid pictures. • Deluxe Streamline Metal Case - Advanced technic, Easy to Install • Smooth Coating - Octagonal Steel case   <p>Motorized projector screen with remote control</p> <p>The overall appearance of the product shall be as per photograph. Product should be of reputed brand.</p>		
60	A5	Multimedia projector	<p>Smart Interactive Projector / Digital Teaching Device with</p> <ul style="list-style-type: none"> • CPU - Intel Core i7 • RAM (GB) - 8 • SSD – 512 GB • OS Compatibility - Windows 10 / 11 Pro • VGA Port - Yes • HDMI Port - YES • No. of USB 2.0 Ports (Nos) - 4 • No. of USB 3.0 Ports (Nos) - 2 • Keyboard & Mouse - YES • Central Controller - Available • Board Aspect Ratio - 16 : 9 • Power Switch: Yes Physical • Touch interface - pen driven • Touch Technology - Infrared • Ability to integrate cameras in future • In built Speakers - Yes 	3	Pc

Appendix B

Revised Section 6 for Package-0144

			<ul style="list-style-type: none"> • Bluetooth connectivity - Yes • Wi-Fi connectivity - Yes • LAN Connectivity - Yes • Power Supply V(AC) - 100-240 • Projector with Arm - Available • Type - Short Throw • Technology - DLP • Brightness (Lumens) - 3000 & above • Projection Lamp - UHP • Life of projection Lamp (In normal Mode) - 5000 Hours • Cabinet - Wall Mounted lockable enclosure • Air Mouse with Laser Pointer - Available • Warranty - 5 Years • BID specific OEM authorization • BIS certification of the product • Enclosure for all the accessories to be provided (Specification: Size H- 34 Inch L- 25.5 Inch W- 11 Inch, MS Cabinet with Lockable facility, a separate lockable tray for Keyboard mouse, Floor stand) • Native Resolution: 1280mm x 800mm • Graphic Mode: WXGA  <p>The overall appearance of the product shall be as per photograph. Product should be of reputed brand.</p>		
--	--	--	--	--	--

Appendix B

Revised Section 6 for Package-0144

61	C11	Table for Students	<p>Computer Table with cable management (for Double sitting) Laminate tabletop. Colour – black. Finish- powder coated. Frame metal - Steel. Dimension: 1800 mm(W) X800 mm (D) X 750 mm (H) approx. Similar or closet o size. Power supply provision on table (2 Switch with twin gang 230V, 6/16 A socket outlet)</p> <p>With modesty panel</p> <p>The overall appearance of the product shall be as per photograph. Product should be of reputed brand.</p>	40	No
62	C12	Lecturer’s console	<p>Computer Table with cable management Laminate tabletop. Colour – black. Finish- powder coated. Frame metal - Steel. Dimension: W 1800 mm X D 800 mm X H 750 mm Similar or closet to size. Power supply provision on table (2 Switch with twin gang 230V, 6/16 A socket outlet)</p> <p>With modesty panel</p> <p>The overall appearance of the product shall be as per photograph. Product should be of reputed brand.</p>	2	No



Appendix B

Revised Section 6 for Package-0144

63	C13	Swivel Chair for Students	 <p style="font-size: small; margin-top: 5px;">Training Chair with writing tablet, foldable</p> <p>Pic 1 Dimension: W 580 X D 510 X H 830 MM Similar or closer to the size. MATERIAL: MESH & WITH MESH CUSHION, 5-Prong nylon base for stability. Twin Wheel heavy-duty swivel. Castor for easy mobility under load. Seat Hot pressed plywood with steel T-Nuts for rigid fastening with PP cover. Back is moulded Bright Bar with stitched Mesh Cloth. Quality tapestry. High density Moulded PU cushion.</p> <p>Design same as pic but without writing shelves.</p> <p>Colour: Will be confirmed at time of purchase. (Provide catalogue)</p> <p>The overall appearance of the product shall be as per photograph. Product should be of reputed brand.</p>	80	No
----	-----	---------------------------	---	----	----

Appendix B

Revised Section 6 for Package-0144

64	C14	Swivel Chair for Lecturer	 <p>Mesh Butterfly Low Back Chair. Mesh Low Back Chair- Specification-Size-H: 1000-1100mm, Seat ht: 460-560mm, D-600mm, W-590 mm. 5-Prong nylon base for stability. Twin Wheel heavy Duty Castor for easy mobility under load. Seat Hot pressed plywood with steel T-Nuts for rigid fastening with mesh cover. Back is moulded Bright Bar with stitched Mesh Cloth. Sturdy steel column gas lift for centre support and seat height adjustment. Telescopic ABS cover over steel column. Lockable synchrony tilt mechanism and with Single piece Die castes PP arm rest adjustable with PP pad. Quality tapestry. High density Moulded PU cushion.</p> <p>Similar or closet to size.</p> <p>The overall appearance of the product shall be as per photograph. Product should be of reputed brand.</p>	3	No						
65	C15	Half-height metal swing door cabinet	 <table border="1" data-bbox="633 1241 965 1383"> <thead> <tr> <th>Description</th> <th>Dimension (W X D X H) Mm</th> </tr> </thead> <tbody> <tr> <td>Without Locking Bar</td> <td>915 X 457 X 915</td> </tr> <tr> <td>Locking Bar</td> <td>915 X 457 X 915</td> </tr> </tbody> </table>	Description	Dimension (W X D X H) Mm	Without Locking Bar	915 X 457 X 915	Locking Bar	915 X 457 X 915	12	No
Description	Dimension (W X D X H) Mm										
Without Locking Bar	915 X 457 X 915										
Locking Bar	915 X 457 X 915										

Appendix B

Revised Section 6 for Package-0144

			<p>Similar or close to size. Material: metal (Steel), anti-rust. Thickness: 0.5--1.2mm Colour: Light Steel gray matte finish. Shelves with adjustable (height), foldable, convertible, extendable. With lock system, steel handel (anti-rust)</p> <p>The overall appearance of the product shall be as per photograph. Product should be of reputed brand.</p>		
66	C16	Printer Table	 <p>Dimensions: L 3ft x W 2.2ft x H 1.7 ft Similar or close to size. Material: Material: Medium density composite (engineered wood) woods boards (1.5 inches thick minimum). All edges covered with PVC edge beading. It should be anti-scratch, moisture proof, stain-resistant and dust resistant, termite proof, water-resistant, and rustproof. Closed back with a high-quality wood laminated material. With castor/wheel and wheel lock system. With cup board system (Two door open system), with one shelve adjustable height.</p> <p>The overall appearance of the product shall be as per photograph. Product should be of reputed brand.</p>	2	No
67	C18	Whiteboard (wall mounted)	<p>Wall – mounted Magnetic Whiteboard (W 2440mm X H 1220 mm)</p> <p>Similar or close to size.</p>	3	No

Appendix B

Revised Section 6 for Package-0144

			<p>Features</p> <ul style="list-style-type: none"> • Magnetic Whiteboard: Attach messages, reminders, to-do lists, photos, etc. • Durable & Stain-Resistant Surface: Easy write on and wipe off without stain. • Aluminium Frame: Durable, rust-proof and lightweight. • Rounded PP Caps: Ensures safety and prevent bumps and scratches. • Handy Pen Tray: Perfect for storing marker and keep them close at hand.  <p>The overall appearance of the product shall be as per photograph. Product should be of reputed brand.</p>														
68	C19	Clock	<table style="width: 100%; border: none;"> <tr> <td style="width: 50%;">Colour</td> <td>SILVER</td> </tr> <tr> <td>Display Type</td> <td>Analog</td> </tr> <tr> <td>Style</td> <td>Classic</td> </tr> <tr> <td>Special Feature</td> <td>Alarm</td> </tr> <tr> <td>Product Dimensions</td> <td>26W x 26H Centimeters Similar or close to size.</td> </tr> <tr> <td>Power Source</td> <td>Battery Powered</td> </tr> </table>	Colour	SILVER	Display Type	Analog	Style	Classic	Special Feature	Alarm	Product Dimensions	26W x 26H Centimeters Similar or close to size.	Power Source	Battery Powered	3	No
Colour	SILVER																
Display Type	Analog																
Style	Classic																
Special Feature	Alarm																
Product Dimensions	26W x 26H Centimeters Similar or close to size.																
Power Source	Battery Powered																

Appendix B

Revised Section 6 for Package-0144

			<p>Room Type Office, Shop, Living Room, Bedroom</p> <p>Shape Round</p> <ul style="list-style-type: none"> • Material of the Frame : Plastic • Ideal for offices • Durable and Long Lasting : Made Wood, Special and Elegant Design for Home Decor Items. • Wall clock with large numerals designed on white face, easy to read quickly. • Beautiful and Elegant Design : This Wall Watch modern captures the trend and adds elegance to your Modular Home and wall decoration. <div style="text-align: center;">  </div> <p>The overall appearance of the product shall be as per photograph. Product should be of reputed brand.</p>		
--	--	--	--	--	--



Appendix B

Revised Section 6 for Package-0144

69	B3	Chair for Students	 <p>Dimension: W 580 X D 510 X H 830 MM Similar or closer to the size. MATERIAL: MESH & WITH MESH CUSHION, 5-Prong nylon base for stability. Twin Wheel heavy-duty swivel. Castor for easy mobility under load. Seat Hot pressed plywood with steel T-Nuts for rigid fastening with PP cover. Back is moulded. Bright Bar with stitched Mesh Cloth. Quality tapestry. High density Moulded PU cushion. Colour: Will be confirmed at time of purchase. (Provide catalogue) Foldable writing shelve/board: 1 cm thick plywood, anti-Termite, waterproof, stain proof, anti-dust, strong material.</p> <p>Overall appearance of product as shown in picture. The product must be from a reputed Brand.</p>	40	No
----	----	--------------------	--	----	----



Appendix B

Revised Section 6 for Package-0144

70	B4	Lecturer's console	 <p>Table 1200L x 4500D x 750mmH Similar or close to size. Material: Material: Material: Medium density composite (engineered wood) woods boards (1.8 inches thick minimum). All edges covered with PVC edge beading. laminated wood tabletop with modesty panel. Metal legs as in picture with wheel and wheel locking system.</p> <p>The overall appearance of the product shall be as per photograph. Product should be of reputed brand.</p>	1	No
71	A3	Luggage Rack	 <p>Dimension: 20 in Ht, 26 in Wd Material: Good quality wood (teak) with plastic wide belts. Capacity: Must be to carry 100 kg minimum. Design: As per picture. Two rectangular frames cross each other and fixed by rust proof sloid knots.</p> <p>Overall appearance of product as shown in picture. The product must be from a reputed brand. As per hotel standard.</p>	4	Pc

Appendix B

Revised Section 6 for Package-0144

72	A5	Safe Deposit Box	 <p>Digital safe locker with keypad, fingerprint sensor, and key lock Spacious interior with 51L capacity Suitable for both home and office use Colour: Silver, White or Grey With advance system</p> <p>Overall appearance of product as shown in picture. The product must be from a reputed brand. As per hotel standard. JVD, Godrej or equivalent.</p> <p>Provide catalogue to the purchaser.</p>	2	Pc
73	A6	Mini-Bar (Fridge)	 <div style="border: 1px solid black; padding: 5px; margin-top: 10px;"> <p style="text-align: center; margin: 0;">- SPECIFICATIONS</p> <ul style="list-style-type: none"> • Rack material : VERRE • Gas used : R600A • Material : Steel • Colour : Black • Volume (L) : 30,000p • Warranty (in years) : 2 • Energy efficiency class : F • Number of racks : 2 • Door reversible : Yes • Door type : Glass Door • Power consumption (kwh/24h) : 0.2400 • Cooling type : Thermo-absorption • Automatic defrost : Yes • Inside light : Yes • Lighting type : LED • Rated Power (W) : 65 • Voltage : 220-240V • Frequency (Hz) : 50-60 • Sound level (dB) (1m in front of the appliance) : No • Height (mm) : 480, Width (mm) : 380, Depth (mm) : 440, Height (mm) : 360, Width (mm) : 295, Depth (mm) : 270 </div> <p>Overall appearance of product as shown in picture. The product must be from a reputed brand. As per hotel standard.</p> <p>JVD Brand, Godrej or equivalent</p>	2	Pc



Appendix B

Revised Section 6 for Package-0144

74	A8	King Size mattress	 <p style="text-align: center;">King Size</p> <p style="text-align: center;">190cm</p> <p style="text-align: center;">182cm</p> <p>Dimension: L 190 cm x W 182 cm x H 30 cm</p> <p>Similar or close to size.</p> <p>Material: Spring mattress,</p> <p>Mattress Material: SmartGRID Technology</p> <p>Carbon Tempered Steel Pocked Coils: High Resilient Support Form</p> <p>Cover Material: Premium Engineered Structured Fabric With Anti-Skid Base</p> <p>Mattress Feel: Soft</p> <p>Overall appearance of product as shown in picture. The product must be from a reputed brand.</p> <p>Provide catalogue to the purchaser.</p>	7	Pc
----	----	--------------------	--	---	----

Appendix B

Revised Section 6 for Package-0144

75	A9	Divan	 <p>Dimension: King size, given in the picture.</p> <p>Material: Steel base. Fabric.</p> <p>The product must be from a reputed brand.</p> <p>Provide catalogue to the purchaser.</p>	7	Pc
76	A10	Bedding set with sheets, Duvet	 <p>Duvet 182cm</p> <p>End product of bedding set.</p> <p>Each set contains: One duvet, 2 bed sheets, 4 nos. of pillows, 4 nos. of pillow cover, 4 numbers of pillow protectors and 1 mattress protector (King size).</p> <p>Duvet: For king size bed. Material: Cotton (500 thread count) maximum, Duvet: Down feather with a cover cotton (500 thread count)</p>	8	Set

Appendix B

Revised Section 6 for Package-0144

		<p>Colour: White</p> <p>Bed sheet:</p> <p>Cotton (500 thread count) maximum</p> <p>Dimension: 108 x 108 inches</p> <p>Similar or close to size.</p> <p>Pillow 4 nos.:</p> <p>Dimension: W 50 x L 75 cm</p> <p>Similar or close to size.</p> <p>Material: Casing: 100% fine cotton</p> <p>Filling: 70% feather, 30% down</p> <p>Height: Medium</p> <p>Colour: White</p> <p>Softness: Medium</p> <p>Medium Support: 1300g for that balance of softness and resilience.</p> <p>Pillow protector:</p> <p>For pillow size W 50 x L 75 cm</p> <p>Similar or close to size.</p> <p>White colour.</p> <p>Pillow cover 4 nos:</p>		



Appendix B

Revised Section 6 for Package-0144

			<p>Pillow cover dimensión: 18 x 27 inches</p> <p>Colour: White</p> <p>Pillow protectors:</p> <p>For pillow size W 50 x L 75 cm</p> <p>White colour.</p> <p>Mattress protector:</p> <p>For King size mattress L 190 cm x W 182 cm x H 30 cm</p> <p>Colour: White</p> <p>Overall appearance of product as shown in picture. The product must be from a reputed brand.</p>		
77	A11	Bed-side lamps	 <p>Exact this type or similar type.</p> <p>Overall appearance of product as shown in picture. The product must be from a reputed brand.</p> <p>Provide catalogue to the purchaser.</p>	4	Pc



Appendix B

Revised Section 6 for Package-0144

78	A13	Bed headboard	 <p>Size: Should fit the bed. Adjustable & Foldable: headboards height can be adjusted to better match the bed with different height mattress, Foldable headboard is easier to carry and storage. Comfortable: Thick cushion padded for comfortable and relaxed resting on it Durable: Wood construction inner and with the metal legs which make the headboard durable Assemble tools should be included. Cushion cover must be suede, or leather (easy wash) Colour: Should match the bed and linen.</p> <p>Overall appearance of product as shown in picture. The product must be from a reputed brand.</p> <p>Provide catalogue to the purchaser.</p>	1	Pc
79	A14	Standing Lamp	 <p>Material: Aluminum Pack Content: 1 Floor Lamp with Holder, Shade Ring and On-off Foot Switch - 1 Lampshade</p>	2	Pc



Appendix B

Revised Section 6 for Package-0144

			<p>Overall appearance of product as shown in picture. The product must be from a reputed brand.</p> <p>Provide catalogue to the purchaser.</p>		
80	A15	Alarm Clock	 <p>Snooze option Colour: Black colour Provision: To schedule for a week. Overall appearance of product as shown in picture. The product must be from a reputed brand.</p>	2	Pc
81	A16	Telephone	 <p>Connectivity Type: Wired Telephone Line Support: 1 Mountable: Desktop, Wall Mountable Product Description Must include Telephone Instrument as well. Not only basic but it also has advanced features like speaker phone, caller id, back lit display, memory for incoming and outgoing calls, digital answering machine, desktop and wall mounting type, sip based voice phones and digital key phones. Colour: Black Overall appearance of product as shown in picture. The product must be from a reputed brand.</p>	2	Pc

Appendix B

Revised Section 6 for Package-0144

			Beetel, Panasonic or equivalent		
82	A17	Throw cushions	<p>INNER Cushion pad, 50x50 cm (20x20 ")</p>  <p>Dimension: Length: 50 cm (20 "), Width: 50 cm (20 ") Similar or close to size. The hidden zipper for the cover easy to remove. Material: Cotton easy-care natural material that you can machine wash. With down feather filled. Colour: White. Overall appearance of product as shown in picture. The product must be from a reputed brand.</p>	8	Pc
83	A18	Stationary Set	<p>Pen, pencil, writing paper, compendium (Leather)</p> <p>Each set contains: Writing pad, ball point pen, pencil, compendium (Leather) A4 size.</p> <p>The product must be from a reputed brand.</p>	2	Set
84	A20	Sofa and coffee table	 <p>Sofa: Design: Like picture. Material: Leather or equivalent. Cover (Colour like picture or equivalent).</p>	2	Set



Appendix B

Revised Section 6 for Package-0144

		<p>2 seater sofa (with spring) Good quality spring with Good quality foam.</p> <p>Overall appearance of product as shown in picture. The product must be from a reputed brand.</p> <p>Provide catalogue to the purchaser.</p> <p>Coffee Table:</p>  <p>Design: Similar like picture Material: Laminated Wood Dimention: L 3 ft x W 3 ft and H 1.5-1.7 approx.</p> <p>Overall appearance of product as shown in picture. The product must be from a reputed Brand.</p> <p>Provide catalogue to the purchaser.</p>			
85	A21	Television set (50")	<p>1.25 m QN90C Neo QLED 4K Smart TV Neo QLED 4K HDR+ with 60W Sound* (In Sizes 55 or above) (QN90C) 50"</p> <p>Overall appearance of product as shown in picture. The product must be from a reputed Brand. Samsung, LG or equivalent.</p>	2	Set

Appendix B

Revised Section 6 for Package-0144

86	A23	Picture with Frame	 <p>Frame material: Wood with canvas picture. Sizes: A3 Overall appearance of product as shown in picture. The product must be from a reputed Brand. Provide catalogue to the purchaser.</p>	4	Pc
87	A24	Writing desk lamp	 <p>Metal body This type of design to match hotel As per picture. Overall appearance of product as shown in picture. The product must be from a reputed Brand. Provide catalogue to the purchaser.</p>	2	Pc
88	A27	Bathroom amenities	<p>Depends on WSC design and reequipments. Body Shampoo, Hair Shampoo, Hair conditional, Body lotion. Toothbrush set, Shaving set, Comb, Luffa, Sewing kit, Hand soap, Vanity kit, Shower Cap, Shoe Shine cloth, Slipper, Sanity Bag, Weighting scale, Tissue Box (to hold tissue) Amenities tray/box.</p>	2	Set



Appendix B

Revised Section 6 for Package-0144

			<p>The product must be from a reputed Brand.</p> <p>Provide hotel size ítems.</p>										
89	A28	Bathroom robes, towels, rugs, mat, etc	 <table border="1" style="width: 100%; border-collapse: collapse;"> <tr> <td style="padding: 5px;">Face Towel</td> <td style="padding: 5px;">30*30cm/50g</td> </tr> <tr> <td style="padding: 5px;">Hand Towel</td> <td style="padding: 5px;">35*75cm/150g</td> </tr> <tr> <td style="padding: 5px;">Bath Towel</td> <td style="padding: 5px;">70*140cm/500g</td> </tr> <tr> <td style="padding: 5px;">Floor Towel</td> <td style="padding: 5px;">50*80cm/350g</td> </tr> </table> <p>Colour: White</p> <p>Material: Cotton</p> <p>Overall appearance of product as shown in picture. The product must be from a reputed Brand.</p> <p>Provide the catalogue to the purchaser.</p>	Face Towel	30*30cm/50g	Hand Towel	35*75cm/150g	Bath Towel	70*140cm/500g	Floor Towel	50*80cm/350g	4	Sets
Face Towel	30*30cm/50g												
Hand Towel	35*75cm/150g												
Bath Towel	70*140cm/500g												
Floor Towel	50*80cm/350g												
90	A29	Hair dryer	<p>HP8100/46 Compact Hair Dryer 2 Flexible heat setting Thermo Protect prevents overheating 1000 Watts.</p>	2	Set								

Appendix B

Revised Section 6 for Package-0144

			<p>Colour: Black</p> <p>The product must be from a reputed Brand.</p> <p>Philips, JVD or equivalent</p>		
91	A8	Twin Size mattress	 <p>1 set: Super single 2 nos. mattress</p> <p>W 107 cm x L 190 cm x H 30 cm approx.</p> <p>Matrerial: Same as Deluxe room King size.</p>	1	Set
92	A9	Divan	<p>Super single for twin.</p> <p>Dimension: W 108 cm x L 202 cm x H (Foot Board) 28.5 cm inclusive of wooden leg 12.7cm</p> <p>Material: Steel base. Fabric.</p> <p>The product must be from a reputed brand.</p> <p>Provide catalogue to the purchaser.</p>	2	Pc
93	A10	Bedding set with sheets, comforter	 	2	Set

Appendix B

Revised Section 6 for Package-0144

			<p>Duvet 182cm End product of bedding set. Each set contains: 2 duvet, 4 bed sheets, 4 nos of pillows, 4 nos of pillow covers, 4 numbers of pillow protectors and 2 mattress protector (Super twin size).</p> <p>Duvet: Material: Cotton (500 thread count) maximum, Duvet: Down feather with a cover cotton (500 thread count) Colour: White</p> <p>For super twin size.</p> <p>Bed sheet: Cotton (500 thread count) maximum</p> <p>Dimension: For super twin size</p> <p>Pillow 4 nos: Dimension: W 50 x L 75 cm</p> <p>Similar or close to size.</p> <p>Material: Casing: 100% fine cotton Filling: 70% feather, 30% down</p> <p>Height: Medium Colour: White Softness: Medium Medium Support: 1300g for that balance of softness and resilience.</p>		
--	--	--	---	--	--

Appendix B

Revised Section 6 for Package-0144

			<p>pillow cover 4 nos:</p> <p>Pillow cover dimensión: 18 x 27 inches</p> <p>Colour: White</p> <p>Pillow protectors:</p> <p>For pillow size W 50 x L 75 cm</p> <p>White colour.</p> <p>Mattress protector:</p> <p>For Super twin size mattress.</p> <p>Colour: White</p> <p>Overall appearance of product as shown in picture. The product must be from a reputed brand.</p>		
94	A13	Bed headboard	<p>For Super twin bed (For super twin size bed)</p> <p>Dimension: For super twin size bed.</p> <p>Material: Description same as deluxe room (King)</p> <p>Provide catalog to the Purchaser for Super Twin bed.</p>	2	Pc
95	A1	Wet Vacuum		1	Pc

Appendix B

Revised Section 6 for Package-0144

			<p>1200W 25L Stainless Steel & ABS Wet & Dry Vacuum Cleaner Vacuum Cleaner Type Canister Material Stainless Steel & ABS 18kPa suction power. With accessories Colour: Silver or light colour Heavy duty Easy clean Two in one: Wet and Dry</p> <p>With bottom wheels.</p> <p>Similar or close to size.</p> <p>Overall appearance of product as shown in picture. The product must be from a reputed Brand.</p> <p>Karcher, Eureka Forbes or equivalent.</p>																																
96	A2	Dry Vacuum (upright)	<div style="display: flex; align-items: center;">  <table border="1" style="border-collapse: collapse; width: 100%;"> <thead> <tr> <th style="text-align: left;">Description</th> <th style="text-align: left;">Specifications</th> </tr> </thead> <tbody> <tr> <td>Working width (mm)</td> <td>300</td> </tr> <tr> <td>Air flow (l/s)</td> <td>48</td> </tr> <tr> <td>Vacuum (mbar/kPa)</td> <td>207/20.7</td> </tr> <tr> <td>Container Capacity (l)</td> <td>5.5</td> </tr> <tr> <td>Max. Rated Input Power (W)</td> <td>Max 1150</td> </tr> <tr> <td>Standard Nominal width</td> <td>35</td> </tr> <tr> <td>Cable Length(m)</td> <td>12</td> </tr> <tr> <td>Sound pressure level (dB(A))</td> <td>67</td> </tr> <tr> <td>Sound Power level (dB(A))</td> <td>80</td> </tr> <tr> <td>Number of motors</td> <td>1</td> </tr> <tr> <td>Brush motor Power (W)</td> <td>-</td> </tr> <tr> <td>Weight(kg)</td> <td>8.4</td> </tr> <tr> <td>Dimension (L & Times; W & Times; H) (mm)</td> <td>320x310x1220</td> </tr> <tr> <td>Energy efficiency class</td> <td>D</td> </tr> </tbody> </table> </div> <p>Similar or close to size.</p>	Description	Specifications	Working width (mm)	300	Air flow (l/s)	48	Vacuum (mbar/kPa)	207/20.7	Container Capacity (l)	5.5	Max. Rated Input Power (W)	Max 1150	Standard Nominal width	35	Cable Length(m)	12	Sound pressure level (dB(A))	67	Sound Power level (dB(A))	80	Number of motors	1	Brush motor Power (W)	-	Weight(kg)	8.4	Dimension (L & Times; W & Times; H) (mm)	320x310x1220	Energy efficiency class	D	2	Pc
Description	Specifications																																		
Working width (mm)	300																																		
Air flow (l/s)	48																																		
Vacuum (mbar/kPa)	207/20.7																																		
Container Capacity (l)	5.5																																		
Max. Rated Input Power (W)	Max 1150																																		
Standard Nominal width	35																																		
Cable Length(m)	12																																		
Sound pressure level (dB(A))	67																																		
Sound Power level (dB(A))	80																																		
Number of motors	1																																		
Brush motor Power (W)	-																																		
Weight(kg)	8.4																																		
Dimension (L & Times; W & Times; H) (mm)	320x310x1220																																		
Energy efficiency class	D																																		

Appendix B

Revised Section 6 for Package-0144

			<p>Overall appearance of product as shown in picture. The product must be from a reputed Brand.</p> <p>Karcher, Ereka Forbes or equivalent.</p>		
97	A3	Washing Machine	<p>Capacity : 11 Kgs Dry Weight. Heating : Electric Heated.</p> <p>Features :</p> <ul style="list-style-type: none"> ❖ Front loading machine, open pocket. ❖ Forward and reverse basket rotation. ❖ Heavy duty high spin. Single motor frequency drive. ❖ 3 compartment automatic soap dispenser through PLC. ❖ Electric operated water inlet valves and drain valve. ❖ Suspension with shock absorber & springs. ❖ Color display with touch screen PLC controlled. ❖ Heavy duty door electric interlock and emergency stop for safety & trouble-free operation. <p>1. Basket Size : Dia. 580 x 416 mm depth.</p> <p>2. Basket Volume : 110 Ltrs.</p> <p>3. Final extraction : 1040 rpm.</p> <p>4. Washing Speed : 30 – 40 rpm (Adjustable).</p> <p>5. G – Force : 350 at final extract.</p> <p>6. Drive Motor : 1.5 Hp (1.1 kW) Motor, 3 Ph. VFD Controlled, HEM / Equivalent make Single motor with variable frequency inverter drive for various speed for wash, Distribution, Low, Medium, High Spin extract.</p> <p>7. Inverter : 2 HP, 3 Phase. Fuji / Equivalent make</p> <p>8. Heater : 6 kW.</p> <p>9. Type of Control : Fully Programmable Logic Controller (PLC) with minimum 20 programs storage capacity with minimum 4 steps in each program, to customize the wash programs according to the type of the linen.</p> <p>10. Display : 4.3" Touch screen color display to visualize the step by step working process, easy to understand and program.</p> <p>11. Safety : Electric interlock with Door limit switch, unbalancing switch and emergency stop for safety & trouble-free operation.</p> <p>12. Door Lock : Machine should have both manual and auto door lock. This makes the door not to open at time of operation.</p> <p>13. Inner Basket : Made of high grade Stainless Steel sheet of SS 304 grade. CNC Perforated basket.</p> <p>14. Outer Drum : Made of high grade stain less steel of SS 304 grade. Outer shell is reinforced by a steel plate.</p> <p>15. Main Body / Outer Cabinet : Made of Stainless Steel front and both sides cover, Die pressed SS Door. Back cover made of MS powder coated.</p> <p>16. Wedges/Lifters : Provided 3 no's of wedges/lifter with perforation.</p> <p>17. Bearing Housing : SKF Heavy duty taper roller bearings, fabricated and sealed in a Cast iron housing.</p> <p>18. Door Opening : Large door design for easy loading and unloading of the linen. Door size: Dia. 400 mm.</p> <p>19. Soap Dispenser : Three chemical compartments for liquid / solid washing agents.</p> <p>20. Water Inlet : Cold water inlet dia. 3/4" (dia. 20 mm), Hot water inlet dia. 3/4" (dia. 20mm), At 2 – 4 bar pressure.</p> <p>21. Drain : Dia. 2" (dia. 50 mm), Electrically operated Valve.</p> <p>22. Electric Supply : 415V, 50Hz, 3ph+N+E.</p> <p>23. Overall Dimension : 850 W x 950 D x 1210 H in mm.</p> <p>24. Machine Weight : 260 Kgs.</p> <p>Similar or close to size.</p> <p>Overall appearance of product as shown in picture. The product must be from a reputed Brand.</p> <p>Preferably IFB, LG or equivalent.</p>	1	Pc

Appendix B

Revised Section 6 for Package-0144

98	A4	Dryer	<p>Capacity : 11 Kg Dry weight.</p> <p>Heating : Electric Heated.</p> <p>Special Features :</p> <ul style="list-style-type: none"> ❖ Industrial Tumbler drier. ❖ Front loading, open pocket. ❖ Forward and reverse basket rotation. ❖ Automatic with cool down feature. ❖ Fully Programmable Controller. ❖ Door Limit switch and Emergency stop for safety & trouble-free operation. ❖ SS fine mesh for collect lint. <p>1. Basket Size : Dia. 681 x 582 mm depth.</p> <p>2. Basket Volume : 212 Ltrs.</p> <p>3. Basket speed : 35 ± 2 rpm.</p> <p>4. Drive Motor : Drive motor of 0.5 hp. HEM / equivalent make.</p> <p>5. Blower Motor : Blower motor of 0.5 hp. HEM / equivalent make.</p> <p>6. Electric Radiator : 9 kW Radiator.</p> <p>7. Type of Control : Fully Programmable Controller with time and temperature and is equipped with the ability to store 5 programs. To customize the programs according to the type of the cloth.</p> <p>8. Display : Digital display with soft buttons.</p> <p>9. Main Body : Made of MS powder coated and cubical welded construction with glass wool insulation.</p> <p>10. Inner Basket : Made of Stainless Steel sheet densely perforated on automatic machines with circles periphery of 1.2mm thick.</p> <p>11. Wedges/Lifters : Provided 3 no's of wedges/lifter.</p> <p>12. Clear Door Opening : Dia. 465mm.</p> <p>13. Hot Air Exhaust : Size: Dia.100mm.</p> <p>14. Lint Screen : Made of Stainless Steel self-collecting lint screen, easily accessible front side.</p> <p>15. Electric Supply : 415V, 50Hz, 3ph+N+E.</p> <p>16. Overall Dimension : 790W x 1100D x 1250H in mm.</p> <p>17. Machine Weight : 290 Kgs.</p> <p>Similar or close to size.</p> <p>Overall appearance of product as shown in picture. The product must be from a reputed Brand.</p> <p>Preferably IFB, LG or equivalent.</p>	1	Pc
----	----	-------	--	---	----



Appendix B

Revised Section 6 for Package-0144

99	A5	Floor scrubbing / polisher	 <p> Motor Power: 1000 Watt Brush Diameter: 17 inch Brush Speed: 180 RPM Motor Rating: 1.5 HP Application: for Floor Cleaning Current Type: 220-240 V 50 Hz Motor Phase: Single Phase Model Number: BDS 43/150 C Classic Noise Level: 75 dB Maximum. Dimension: 590 x 430 x 1180mm Working width of Brushes (mm): 430mm Rated input power (W): 1500W Power Source: Electricity Similar or close to the size. Single disc machines must be used for cleaning and treating floors. Via the movement of the brush or pad, single disc machines can scrub, smooth and polish floors. Single disc scrubbers should be the most versatile, multipurpose and general machines for maintenance and cleaning of all types of floors and carpets. It must use a single rotating disc which works on the floor to clean it. Overall appearance of product as shown in picture. The product must be from a reputed Brand. Preferably Karcher, Eureka forbes or equivalent. </p>	1	Pc
----	----	----------------------------	---	---	----



Appendix B

Revised Section 6 for Package-0144

100	A6	Housekeeping Trolley	 <p>Cleaners trolley on an empty floor of hotel Sections as per pictures or equivalent Dimension: Height (mm) 1150 Width (mm) 1410 Depth (mm) 500 Weight (kg) 42.000 Similar or close to size. Colour: Grey PRODUCT ADVANTAGES With top organizer load capacity up to 100kg. Housekeeping Cart, metal, top organizer, 3 fixed shelves, 1 full & 1x 3/4 zipper grey bags, 8" pneumatic wheels, metal bag cover, H1150/L1410/D485mm, anthracite grey. Wheel with lock system</p> <p>The overall appearance of the product shall be as per photograph. Product should be of reputed brand.</p>	2	Pc
101	B10	Notice Board	 <p>60" x 48" Cork/Dry Erase Combo Board, Magnetic Presentation Whiteboard/Bulletin Combination Board.</p> <p>Board Size: L 5 x W 4 Feet</p>	1	Pc

Appendix B

Revised Section 6 for Package-0144

			<p>Similar or close to size. Colour: Silver Material: Aluminium Alloy Steel Mounting Type: Wall Mount Frame Material: Aluminium</p> <p>Overall appearance of product as shown in picture. The product must be from a reputed Brand.</p>		
102	B11	Key Box with Cover wall mount	 <p>Metal Key Box: DIMENSION:558X280X52mm SPECIFICATION: 50keys COLOR: Light Grey MEAS:580X400X310mm Weight: 3Kg Similar or close to size.</p> <p>Overall appearance of product as shown in picture. The product must be from a reputed Brand.</p>	1	set
103	B12	Movable White board	 <p>Mobile Magnetic Whiteboard (2440mm X 1220 mm) with Rolling wheels Similar or close to size.</p> <ul style="list-style-type: none"> • Magnetic Whiteboard: Attach messages, reminders, to-do lists, photos, etc. • Durable & Stain-Resistant Surface: Easy write on and wipe off without stain. • Aluminium Frame: Durable, rust-proof and lightweight. • Rounded PP Caps: Ensures safety and prevent bumps and scratches. • Handy Pen Tray: Perfect for storing marker and keep them close at hand. <p>Swivel Wheel with lock system.</p>	4	set

Appendix B

Revised Section 6 for Package-0144

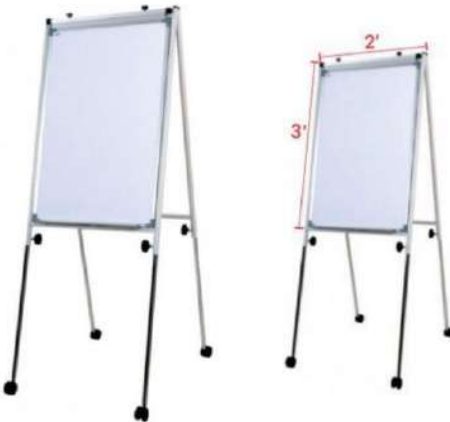
			Overall appearance of product as shown in picture. The product must be from a reputed Brand.		
104	B13	First aid box	 <ul style="list-style-type: none"> • Compliance with MOM Guidelines • Individually Wrapped Sterile Adhesive Dressing x 20 • Handicrepe Bandage 5cm x 1 • Handicrepe Bandage 10cm x 1 • Absorbent Gauze 10'S x 5 • Hypoallergenic Tape x 1 • Triangular Bandage x 4 • Scissors x 1 • Safety Pin 10'S x 1 • Disposable Glove Pair (Latex) x 2 • Eye Shield x 2 • Eye Pad x 2 • Disposable CPR Kit x 1 • Torch Light x 1 • Water for Injection 5x20ml x 1 <p>Similar or close to the item.</p> <p>Overall appearance of product as shown in picture. The product must be from a reputed Brand.</p>	4	set
105	B14	Flip chart board	 <p>Conference Flipchart</p> <ul style="list-style-type: none"> • 2' x 3' • With Roller & Magnet • Extra strong twist clamp system suitable for all flipchart papers • Magnetic whiteboard surface • Full length pen-tray for easy access to markers erasers • Telescopic leg for height adjustment • Lockable nylon castors for extra stability & mobility • Easy storage <p>Flip Chart/Conference Flipchart/With Magnetic & Roller size: 2' x 3' / 3' x 4' Similar or close to size.</p> <ul style="list-style-type: none"> • With Roller & Magnet 	6	Set



Appendix B

Revised Section 6 for Package-0144

			<ul style="list-style-type: none"> • Extra strong twist clamp system suitable for all flipchart papers • Magnetic whiteboard surface • Special Note: Use Flip charts Paper Pad <p>Detachable board (Can be kept horizontally, if required)</p> <p>Overall appearance of product as shown in picture. The product must be from a reputed Brand.</p>		
106	B15	Iron – cordless	 <p>Safe on all ironable fabrics: Even delicate like silk. Power: 1250 w or more Soleplate gliding performance: 4 stars. Soleplate: Steam glide Water tank capacity: 1300 ml Hose length: 1.6 m. Integrated power plug Power cord length: 1.65 m Precision steam tip Ready to use: Light indicator, Sound indicator. Refill any time during use. Soleplate scratch resistance: 4 stars For all ironable fabrics No burns No temperature settings are needed. ProVelocity steam engine Cordless iron with charger stand. Weight of iron: 1,3 kg approx. Weight of iron + base: 2,72 kg approx. Calc clean container</p>	2	Pcs

Appendix B

Revised Section 6 for Package-0144

108	B17	Tamper		4	Pcs
109		Rattleware	 <p>Rattleware. Rattleware Knock Box (6"x5.5"x4")</p> <p>Box Knock Basic 6" x 5.5" x 4"</p>	4	Pcs
110		Mat Tamping Corner CAFELAT	 <p>Dimensions: L19.5 cm X W14.8cm. A perfect size for portafilter and tamper placement. Weight: 215 gm.</p>	4	Pcs

APPENDIX – C

PKG 0145: Training Equipment, Tools & Furniture for setting up of Digital Animation Facility at WSC

AS PER EXISTING BID DOCUMENT						REVISED SPECIFICATION /QUANTITY			
SL. NO	ITEM NO.	ITEM	SPECIFICATION	QUANTITY	UNIT	ITEM	SPECIFICATION	QUANTITY	UNIT
1	A1	Multimedia Projector	Smart Interactive LCD Projector / Digital Teaching Device with • Hard Disk Capacity (GB) - 1000	2	No.		Smart Interactive Projector / Digital Teaching Device with • SSD (GB) - 1000 (Other Specification related to this item will remain same as per original bid document)	8	No.
2	A2	Projection Screen - wall mounted		2	No.		Same as per Bid document	8	No.
3	E1	Student and Staff Chair		42	No.		THIS ITEM IS CANCELED		
4	E2	Drawing Table (Sits 4)		11	No.		Add following- Wheels attached to drawing table must have wheel locking system		
5	E3	Metal cabinets with doors		2	No.		Same as per Bid document	8	No.
6	E4	Locked Metal Cubby Bag Cabinet	Bag Compartment Shelves	4	No.	Bag Compartment Shelves	Locked Metal Cubby Bag Cabinet (Other Specification related to this item will remain same as per original bid document)	16	No.
7	E5	Whiteboard (2440mm X 1220mm)		1	No.			7	No.
8	E6	Notice Board		1	No.			4	No.
9	E7	Key Box		1	No.			4	No.

APPENDIX – C

PKG 0145: Training Equipment, Tools & Furniture for setting up of Digital Animation Facility at WSC

AS PER EXISTING BID DOCUMENT						REVISED SPECIFICATION /QUANTITY			
SL. NO	ITEM NO.	ITEM	SPECIFICATION	QUANTITY	UNIT	ITEM	SPECIFICATION	QUANTITY	UNIT
10	A1	PC Workstations	<p>Graphics Card- NVIDIA RTX A4000 16GB . System should support up to NVidia RTX 5000 32GB CARD in future ready. Certified drivers for CAD applications to be supplied.</p> <p>Form Factor with Tool free design- Convertible Mini Tower with tool-less entry and maintenance. System should feature Active Acoustic Reduction, with low noise level. System should be rack-mountable</p>	41	No.		<p>Add following –</p> <ol style="list-style-type: none"> 1. Monitor Size- 28 Inch, 1080P(Minimum) 2. Graphics Card- NVIDIA RTX A4000 20GB GDDR6 . System should support up to NVidia RTX 5000 32GB CARD in future ready. 3. Form Factor with Tool free design- Convertible Mini Tower/Tower with tool-less entry and maintenance. System should feature Active Acoustic Reduction, with low noise level. 4. CPU stand with with wheel lock <p>(Other Specification related to this item will remain same as per original bid document)</p>	123	No.
11	A2	Colour Scanner	<p>Minimum configuration: USB and parallel port connectivity</p>	1	No.		<p>Minimum configuration: Connectivity - 10/100/1000 Ethernet; 1 Hi-Speed USB Host (rear); 1 Hi-Speed USB Host (walk-up) (Other Specification related to this item will remain same as per original bid document)</p>	3	No.

APPENDIX – C
PKG 0145: Training Equipment, Tools & Furniture for setting up of Digital Animation Facility at WSC

AS PER EXISTING BID DOCUMENT						REVISED SPECIFICATION /QUANTITY			
SL. NO	ITEM NO.	ITEM	SPECIFICATION	QUANTITY	UNIT	ITEM	SPECIFICATION	QUANTITY	UNIT
12	A3	Projection Screen - wall mounted		2	No.		THIS ITEM IS CANCELED		
13	A4	Multimedia Projector	Smart Interactive LCD Projector / Digital Teaching Device with • Hard Disk Capacity (GB) - 1000	2	No.		THIS ITEM IS CANCELED		
14	A5	Digitizing Tablet		41	No.		Same as per Bid document	123	No.
15	B3	3D Sculpting Software	3D Sculpting Software	41	No.		Zbrush with 1 year Subscription	123	No.
16	B4	Substance Painter Software	Substance Painter Software	1	Lot	Adobe Substance 3D Collection	Adobe Substance 3D Collection with 1 year Subscription (1 Lot Contains Minimum 41 No.)	3	Lot
17	B7	Adobe cloud creative suite	Adobe cloud creative suite	41	No.		Adobe cloud creative suite which minimally includes Acrobat Photoshop, illustrator, Animate and After Effects, Premiere Pro, Firefly, Animate.	123	No.
18	E1	Computer Table with cable management as shown	Finish- power coated	22	No.		Finish- powder coated. Add following: - 1. Power supply provision on table 2 sets of - 2 Switch with twin gang 230V,16/6 A socket outlet.	66	No.

APPENDIX – C

PKG 0145: Training Equipment, Tools & Furniture for setting up of Digital Animation Facility at WSC

AS PER EXISTING BID DOCUMENT						REVISED SPECIFICATION /QUANTITY			
SL. NO	ITEM NO.	ITEM	SPECIFICATION	QUANTITY	UNIT	ITEM	SPECIFICATION	QUANTITY	UNIT
		(for Double sitting)					2.Provision for 2 CPUs, 2 Key Board Trays With modesty panel.		
19	E2	Student Chair		40	No.		Same as per bid document	160	No.
20	E3	Teachers' Chair		2	No.		Same as per bid document	8	No.
21	E4	Metal cabinets with doors		2	No.		THIS ITEM IS CANCELED		
22	E5	Metal Locked Metal Cubby Bag Cabinet		4	No.		THIS ITEM IS CANCELED		
23	E6	Whiteboard (2440mm X 1220mm)		2	No.		THIS ITEM IS CANCELED		
24	E7	Notice Board		1	No.		THIS ITEM IS CANCELED		
25	E8	Key Box		1	No.		THIS ITEM IS CANCELED		
26	A1	PC Workstations	same as per bid document	41	No.		THIS ITEM IS CANCELED		
27	A2	Colour Scanner		1	No.		THIS ITEM IS CANCELED		
28	A3	Projection Screen - wall mounted		2	No.		THIS ITEM IS CANCELED		

APPENDIX – C

PKG 0145: Training Equipment, Tools & Furniture for setting up of Digital Animation Facility at WSC

AS PER EXISTING BID DOCUMENT						REVISED SPECIFICATION /QUANTITY			
SL. NO	ITEM NO.	ITEM	SPECIFICATION	QUANTITY	UNIT	ITEM	SPECIFICATION	QUANTITY	UNIT
29	A4	Multimedia Projector	Smart Interactive LCD Projector / Digital Teaching Device with • Hard Disk Capacity (GB) - 1000	2	No.		THIS ITEM IS CANCELED		
30	A5	Digitizing Tablet		41	No.				
31	B3	3D Sculpting Software	3D Sculpting Software	41	No.		THIS ITEM IS CANCELED		
32	B4	Substance Painter Software	Substance Painter Software	1	Lot		THIS ITEM IS CANCELED		
33	B7	Adobe cloud creative suite	Adobe cloud creative suite	41	No.		THIS ITEM IS CANCELED		
34	E1	Computer Table with cable management as shown (for Double sitting)	same as per bid document	22	No.		THIS ITEM IS CANCELED		
35	E2	Student Chair		40	No		THIS ITEM IS CANCELED		
36	E3	Teachers' Chair		2	No		THIS ITEM IS CANCELED		

APPENDIX – C
PKG 0145: Training Equipment, Tools & Furniture for setting up of Digital Animation Facility at WSC

AS PER EXISTING BID DOCUMENT						REVISED SPECIFICATION /QUANTITY			
SL. NO	ITEM NO.	ITEM	SPECIFICATION	QUANTITY	UNIT	ITEM	SPECIFICATION	QUANTITY	UNIT
37	E4	Metal cabinets with doors		2	No.		THIS ITEM IS CANCELED		
38	E5	Locked Metal Cubby Bag Cabinet	Bag Compartment Shelves	4	No.		THIS ITEM IS CANCELED		
39	E6	Whiteboard (2440mm X 1220mm)		2	No.		THIS ITEM IS CANCELED		
40	E7	Notice Board		1	No.		THIS ITEM IS CANCELED		
41	E8	Key Box		1	No.		THIS ITEM IS CANCELED		
42	A1	PC Workstations	same as per bid document	41	No.		THIS ITEM IS CANCELED		
43	A21	Colour Scanner		1	No.		THIS ITEM IS CANCELED		
44	A3	Projection Screen - wall mounted		2	No.		THIS ITEM IS CANCELED		
45	A4	Multimedia Projector	Smart Interactive LCD Projector / Digital Teaching Device with • Hard Disk Capacity (GB) - 1000	2	No.		THIS ITEM IS CANCELED		
46	A5	Digitizing Tablet		41	No.		THIS ITEM IS CANCELED		

APPENDIX – C

PKG 0145: Training Equipment, Tools & Furniture for setting up of Digital Animation Facility at WSC

AS PER EXISTING BID DOCUMENT						REVISED SPECIFICATION /QUANTITY			
SL. NO	ITEM NO.	ITEM	SPECIFICATION	QUANTITY	UNIT	ITEM	SPECIFICATION	QUANTITY	UNIT
47	B3	3D Sculpting Software	3D Sculpting Software	41	No.		THIS ITEM IS CANCELED		
48	B4	Substance Painter Software	Substance Painter Software	1	Lot		THIS ITEM IS CANCELED		
49	B7	Adobe cloud creative suite	Adobe cloud creative suite	41	No.		THIS ITEM IS CANCELED		
50	E1	Computer Table with cable management as shown (for Double sitting)	same as per bid document	22	No.		THIS ITEM IS CANCELED		
51	E2	Student Chair		40	No		THIS ITEM IS CANCELED		
52	E3	Teachers' Chair		2	No		THIS ITEM IS CANCELED		
53	E4	Metal cabinets with doors		2	No.		THIS ITEM IS CANCELED		
54	E5	Locked Metal Cubby Bag Cabinet	Bag Compartment Shelves	4	No.		THIS ITEM IS CANCELED		
55	E6	Whiteboard (2440mm X 1220mm)		2	No.		THIS ITEM IS CANCELED		

APPENDIX – C

PKG 0145: Training Equipment, Tools & Furniture for setting up of Digital Animation Facility at WSC

AS PER EXISTING BID DOCUMENT						REVISED SPECIFICATION /QUANTITY			
SL. NO	ITEM NO.	ITEM	SPECIFICATION	QUANTITY	UNIT	ITEM	SPECIFICATION	QUANTITY	UNIT
56	E7	Notice Board		1	No.		THIS ITEM IS CANCELED		
57	E8	Key Box		1	No.		THIS ITEM IS CANCELED		

APPENDIX - D

REVISED SECTION-6 FOR PACKAGE 0146

SERIAL NO	ITEM	PICTURE	SPECIFICATION	QUANTITY	UNIT
1	Nurse Call Bell System with installation for whole ward 1 & 2 (sample model)		<p>Product dimension-15 x 12 x 10 cm; 250 Grams, Item weight-250gm.</p> <p>Nurse Call systems are used in many environments, including but not limited to:</p> <ul style="list-style-type: none"> a. Hospital Wards b. Nursing Homes c. Day Clinics d. Private Patient Rooms e. High Dependency Unit f. Consulting Rooms g. Disabled Toilets h. X-ray Departments i. Temporary Buildings j. Specification-Specification- Example- 	4	Nos
			<p>Digital Projection: Short throw, DLP with LED Source, HD resolution quality projection with 3D & interactivity enabled Optical Source: High intensity RGB 4 LED, Auto Focus, Optical Module 1500 ANSI Lumens brightness through Overlapping Technology Minimum 30,000 hrs. Lamp Life since it is LED technology Native Resolution: HD [1920 x 1080] Image Size :up to 120 inches (Diagonally) Throw Ratio 0.8 Contrast Ratio 800:1 Aspect Ratio 16:9 Computing Unit Intel i5 10th Generation RAM 16 GB Operating System Windows 10 Storage 1TB SSD Storage Camera for Video Interactivity Dual Cameras, 8 Megapixel camera with wide angle vision each</p> <p>Audio Capabilities 20 w Integrated Speakers - Wide-band frequency response speaker design. Channel Microphone - Integrated 4 Channel Mic (2 Hand Mic & 2 Lapel Mic) Microphone - High-sensitivity piezoelectric MEMS microphone that captures sound from distance of up to 10 meters Interfaces and Connectivity Bluetooth 5.1 & Wi-Fi enabled Ethernet Port 4 USB 3.0 Ports 3 HDMI Ports (2IN and 1OUT) 4G LTE Sim support Interactive IR based Remote Controller Built-in Sensors Temperature Monitor, Gyroscope, etc. Keystone 4 Corner Keystone Correction Portability Light weight (weighing less than 4 kgs) and easy to carry (in a backpack). Power consumption Power Consumption less than 150 W Power Supply AC input 110–240V, 50/60 Hz Warranty:1 Year</p> <p>Sessions (Conference) Interactive video forum; share documents and files, stream media, chat, use the whiteboard, and share screen. Web Casting Virtual meeting room with media streaming and active participation through (ask a question) chat, audio, video, and content sharing.</p> <p>Live Streaming Stream your events, programs or any important moments lively with large audiences. Chat One to one and group chat with emoticons and file transfer</p>		





APPENDIX - D

REVISED SECTION-6 FOR PACKAGE 0146

SERIAL NO	ITEM	PICTURE	SPECIFICATION	QUANTITY	UNIT
2	Projector and motorized screen or whiteboard		<p>Whiteboard Collaborative whiteboard with multiple tools enables the session live and effective.</p> <p>Screen Sharing Share screens and applications during sessions.</p> <p>Video/Audio Calls High-quality video/audio calling to individuals or group discussions.</p> <p>Session Scheduler Schedule instant, future, or repeating sessions with integrated and flexible real time email and SMS messaging.</p> <p>Session Recorder Audio and video recording of sessions including screens and share with the participants who have attended the session. The recordings to be saved in WEBM formats.</p> <p>Media Content Streaming Share the media content (Audio and video) during the sessions.</p> <p>Calendar Provide a comprehensive view of all scheduled activity that can be integrated with external calendars.</p> <p>Realtime Notifications Real time email and SMS notifications</p> <p>Storage Integrated smart cloud storage with automatic tagging & store all files shared in sessions.</p> <p>Search Keyword search across Contacts, Sessions, Chat, Subscribers, Storage, meetings</p> <p>File Sharing File sharing with automatic backup to storage and integration with sessions and Chat.</p> <p>Department Profile Departmental details with team workflow management and an Excel bulk upload feature to ease the process.</p> <p>Directory Management Manage departmental and personal contacts, integration with sessions, classes, and courses.</p> <p>Dashboard, Reports & Analytics Department Dashboard for analytics, and reports.</p> <p>Participants Able to connect at least 25 participants in interactive AV sessions, at least 200 participants in a webcasting session, and 1000 participants in a one way live streaming session.</p> <p>Security Data at transfer and Data on rest to be encrypted with appropriate technology and the portal to work only in HTTPS protocol.</p> <p>Simultaneous Sessions Capability to handle multiple sessions simultaneously</p> <p>File Size Should be able to share files of size up to 50 MB through chat sessions.</p> <p>High Quality Recording Record full HD video and audio in MP4 format</p> <p>Session Management Create, Edit and Delete/cancel Instant and Scheduled Capture sessions.</p> <p>Crop or Trim the Video Trim or crop the recording before sharing.</p> <p>Tagging Automatically generate and attach tags to the captured video or manually tag using subject, topic etc.</p> <p>Playback Playback locally stored recordings through library.</p> <p>Sync and Archive Recording to be stored locally and synced to storage automatically.</p> <p>Video Library Overview of all captures with title, date and time, and other tags.</p> <p>Calendar View and filter sessions based on Title, Date and Time, Tags, and Description.</p> <p>Notifications Automatic notifications through email and SMS.</p> <p>Reports Provide summary and detailed reports on viewing and recording activity and enable view and download reports based on Date and Status.</p> <p>Device Check Check and configure hardware before session recordings.</p>	4	Nos









APPENDIX - D

REVISED SECTION-6 FOR PACKAGE 0146

SERIAL NO	ITEM	PICTURE	SPECIFICATION	QUANTITY	UNIT
			<p>Configure Configure storage folder, microphone & camera etc.</p> <p>File Types The recorded files to be stored in either MP4 or WEBM formats</p> <p>File Size Use appropriate compression technology to minimize the recorded file size and have option to record in multiple resolutions</p>		
4	Electronic Height & Weight Scale (sample model)		<p>Specification-Item weight-700gm, Productdetails-20 x 20 x 15 cm; 700 Grams, Itemheight-15 Centimeters, Itemweight-20 Centimeters ,it should be digital one.</p>	4	Nos
5	Medicine Trolley (sample model)		<ul style="list-style-type: none"> · Dimensions: 80cm x 45cm x 85cm · Drawer dimensions: 50cm x 40cm x 12cm · Weight capacity: 50kg · Casters: 4 smooth-rolling casters, 2 with brakes · Specification- · Size: 850*520*990mm · Drawer: 5 drawers · Structure: mainly made of aluminum, steel and ABS plastic · Standard Accessories: defibrillator shelf, sliding side shelf, IV stand, two trash cans, flexible material storage, needle disposal holder, hand soap holder 	2	Nos
6	Emergency Trolley (Crash Cart) (sample model)		<p>KY40 QR Emergency crash cart with Defibrillator shelf</p> <ul style="list-style-type: none"> * CPR board with storage * Adjustable IV pole * Oxygen cylinder holder * Disposable serial seal management system * Ergonomic Handle * Push style sub-table * Drawer system * Drawer divider for medicine storage * 125 mm caster with diagonal locking mechanism * Fully locking key mechanism * Body made up of powder coated steel * Cover of ABS plastic *Model: Crash Cart KY40 QR Series. 	2	Nos
7	Surgical/ Medical Equipment				
A	Scissors (sample model)		<p>Colour-Steel</p> <p>Material-Stainless,Stainless Steel,Steel</p>	10	Nos
B	Dressing - sharp/sharp straight 11.5cm (sample model)		Dressing - sharp/sharp straight 11.5cm	10	Nos



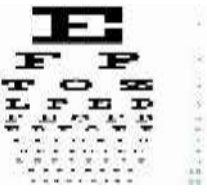

APPENDIX - D

REVISED SECTION-6 FOR PACKAGE 0146

SERIAL NO	ITEM	PICTURE	SPECIFICATION	QUANTITY	UNIT
C	Sharp/blunt straight 11.5cm (sample model)		Sharp/blunt straight 11.5cm Premium Quality Dressing Surgical Scissor Sharp+Sharp 5" Straight	10	Nos
B	Forceps				
A	Dissecting Forceps - toothed 13cm (sample model)		Dissecting Forceps - toothed 13cm	10	No
B	Dissecting Forceps - non-toothed 13cm (sample model)		Dissecting Forceps - non-toothed 13cm	10	No
C	Dressing Forceps (sample model)		Dressing Forceps	10	No
D	Sponge Holding Forceps (sample model)		Sponge Holding Forceps	5	No
E	Needle Holder (Mayo Hegar, 18cm) (sample model)		Needle Holder (Mayo Hegar, 18cm)	2	No
C	ENT&EYE				
A	Snellen Chart (sample model)		Easily can be hanged everywhere with strong holder will not be brake. Distance Vision chart measures 11? wide by 24? high. Eye Distance Vision Chart With Regular 20' distance. Letters are written clearly and Proper indicated. 1 English Vision Test Chart	2	Nos
D	RESPIRATORY				
A	Airway (Lateral) of various sizes (Gudels Airway) (sample model)		Guedel Pattern Airway, Bite Blocks are colour coded for size identification. Guedel Airways is used to maintain an unobstructed oro-pharyngeal airway. Bite blocks are fitted in the Airway to avoid airway occlusion and biting of tongue. Smooth Airway Path For Easy Cleaning.	8	set
			Perfect for Elder and Kids This machine is easy to use and more suitable for elder and kids. It is perfect for home use, providing dependable efficient nebulization treatments		

APPENDIX - D

REVISED SECTION-6 FOR PACKAGE 0146

SERIAL NO	ITEM	PICTURE	SPECIFICATION	QUANTITY	UNIT
B	Nebulizer air compressor (sample model)		<ul style="list-style-type: none"> Effective For Cough, Wheezing, Asthma, Cold, Bronchitis and other conditions requiring nebulization. Suits for personal and professional use at home and hospital on daily basis for adult and child Product is Compatible with doctor prescribed medicine or can be used only with saline water and comes with 2 Year warranty Bio-Compatibility tested mask kit is approved by the testing lab of GOL Helps Treatment of Respiratory Conditions: Effective for cough, wheezing, Asthma, COPD, Bronchitis and other conditions requiring nebulization. The product is compatible with doctor prescribed medicine or can be used only with saline water. Comes with 2 year warranty 	2	Nos
C	Peak Flow Meter (sample model)		<ul style="list-style-type: none"> Accuracy and repeatability Suitable for use with disposable mouthpiece Measurement range 60-800 L/min ,atleast pack of 50pcs 	5	Nos
D	Spirometer (sample model)		<p>Digital Spirometer Compact device - Best quality break-resistant plastic, 3-ball incentive breathing exerciser for Home Use Breathing Exerciser – has 3 chambers for differing inhalation rates - from 600 cc/sec to 1200 cc/ sec Helpful to those who recover from surgery, cough, lung discomfort, colds, and sub-par respiratory issues Helps achieve optimum lung capacity and restoring disrupted breathing patterns The pipe has good bending resistance doesn't affect the patient posture. Can be dismantled for cleaning .</p>	2	No
E	Portable Motor Suction (sample model)		<p>It's the commonly applied medical device for use in the emergency room, operation room, and for nursing in sickroom and home healthcare. Removing respiratory secretions excess saliva, mucus, and cough when the patient is unable to. Clearing the airway of blood. Assisting a patient who is vomiting while seizing or unconscious. Large Flux and Low-Noise Design: Diligently designed to produce high flux for smooth removal of fluids such as secretion and mucus from body cavities. The high-quality engineering and premium material allows for a silent suction. process to keep the patients comfortable and relaxed</p>	1	No
E	RECTAL & URINARY				



APPENDIX - D

REVISED SECTION-6 FOR PACKAGE 0146

SERIAL NO	ITEM	PICTURE	SPECIFICATION	QUANTITY	UNIT
A	Bedpan – S/S (sample model)		Bedpan – S/S	5	No
B	Bedpan – plastic (sample model)		Bedpan – plastic	20	No
C	Commode, steel c/w adjustable arm (sample model)		Commode, steel c/w adjustable arm	8	No
D	Protoscope, sterile disposable (25/box), small or large (sample model)		Protoscope, sterile disposable (25/box), Large size (each box contain 25pcs)	2	No
E	Urinal – S/S (sample model)		Urinal – S/S-stainless steel need	5	No
F	Urinal – plastic with cover autoclavable (sample model)		Urinal – plastic with cover autoclavable	20	No
G	Bedpan (disposal) (sample model)		Bedpan (disposal sheet)	10	No
H	Urine bag holders – hooks (sample model)		hooks	20	No
F	RECEPTACLES				

APPENDIX - D

REVISED SECTION-6 FOR PACKAGE 0146

SERIAL NO	ITEM	PICTURE	SPECIFICATION	QUANTITY	UNIT
A	Trays (S/S) 12"x8"x2" with cover (sample model)		Trays (S/S) 12"x8"x2" (l*w*h) with cover	10	No
B	Trays (Plastic) 18"x5"x2" (sample model)		Trays (Plastic) 18"x5"x2" (l*w*h)	20	No
C	Trays (Thermoplastic, 4 compartments)		Trays (Thermoplastic, 4 compartments)	10	No
D	Trays (meal)		Trays (4 compartments is use for wound dressing or medical/clinical procedures)	10	No
E	Round bowl (Plastic) 0.45 L		Round bowl (Plastic) 0.45 L	20	No
F	Round bowl (Plastic) 1.1 L		Round bowl (Plastic) 1.1 L	20	No
G	Round bowl (Plastic) 1.6 L		Round bowl (Plastic) 1.6 L	20	No
H	Basin (Plastic) 240x110mm		Basin (Plastic) 240x110mm	20	No
I	Basin (Plastic) 290x125mm		Basin (Plastic) 290x125mm	20	No
J	Basin (Plastic) 345x125mm		Basin (Plastic) 345x125mm	20	No
K	Basin (S/S) 345x125mm		Basin (S/S) 345x125mm	10	No
L	Kidney dish (Plastic) 10 " (sample model)		Kidney dish (Plastic) 10"	20	No





APPENDIX - D

REVISED SECTION-6 FOR PACKAGE 0146

SERIAL NO	ITEM	PICTURE	SPECIFICATION	QUANTITY	UNIT
M	Kidney dish (Plastic) 12" (sample model)		Kidney dish (Plastic) 12"	20	No
N	Kidney dish (S/S) 12" (sample model)		Kidney dish (S/S) 12"	5	No
O	Gallipot (Plastic) 6 Oz (sample model)		Gallipot (Plastic) 6 Oz	20	No
P	Gallipot (S/S) 6 Oz (sample model)		Gallipot (S/S) 6 Oz	5	Nos
Q	Jug (Plastic), measuring - 0.5L (sample model)		Jug (Plastic), measuring - 0.5L	10	Nos
R	Jug (Plastic), measuring - 1L (sample model)		Jug (Plastic), measuring - 1L	10	Nos
S	Jug (Plastic), measuring - 2L (sample model)		Jug (Plastic), measuring - 2L	10	Nos
T	Jug (S/S), measuring – 4L (sample model)		Jug (S/S), measuring – 4L	5	Nos
U	Sputum Mug (Plastic) (sample model)		Sputum Mug (Plastic)	10	Nos
V	Pail (Plastic) – 5L (Bucket) (sample model)		Pail (Plastic) – 5L (Bucket)	5	Nos
G	MEDICATION / IV				
A	Drip stand – portable Movable with wheel caster (sample model)		Drip stand – portable Movable with wheel caster	6	Nos
B	Infusion pump (sample model)		Infusion pump	4	Nos
C	Syringe pump (sample model)		Syringe pump	2	Nos



APPENDIX - D

REVISED SECTION-6 FOR PACKAGE 0146

SERIAL NO	ITEM	PICTURE	SPECIFICATION	QUANTITY	UNIT
D	Tourniquet (elcro) (sample model)		Tourniquet (elcro)	5	Nos
E	IV solutions (sample model)		IV solutions ,500ml Sodium Chloride, Dextorse Saline, Dextrose 5% NS-500ML,DNS-500ML,RL500ML,NS-100ML	20	Nos
8	MONITORING EQUIPMENT				
A	Weighing scale – adult (waist high, electrical) (sample model)		Specification- Item weight-700gm, Productdetails-20 x 20 x 15 cm; 700 Grams, Itemheight-15 Centimeters, Itemweight-20 Centimeters	2	Nos
B	Digital thermometer (Terumo) (sample model)		<ul style="list-style-type: none"> · Accuracy: Fast accurate readings within 90 seconds Accuracy is +0.1degrees celcius · Efficiency: Easy to read digital display Water, alcohol and antiseptic solution resistant Durable, mercury-free design · Economic: Long battery life (lithium) Approximately 10,000 measurements per thermometer. Automatic ON/OFF switch when the thermometer is removed or returned to case 	10	Nos
C	Digital thermometer (Thermoscan) (sample model)		<ul style="list-style-type: none"> · Non Contact and Accurate Readings : Non-contact infrared measurement. Measuring distance is under 1-2inch, while avoiding cross infection. The forehead thermometer medical has been clinically tested, and has a very small error margin. It is actually more accurate and healthier than standard mercury thermometers. · Sound Alarm : High-accuracy infrared measurement, when the temperature is over, audible alert will trigger. The HD LED screen displays clear and crisp numbers that are easy to read. · Multi-Purposes : The Forehead thermometer is designed for all ages: adults, infants and elders. It support to take human temperature. · Memory Feature : It can store up to 32 temperature readings and recall them at any time. This comes in handy for keeping a record, and makes it convenient for babies, children, adults. Also it has auto shutdown feature for power saving. 	20	Nos



APPENDIX - D

REVISED SECTION-6 FOR PACKAGE 0146

SERIAL NO	ITEM	PICTURE	SPECIFICATION	QUANTITY	UNIT
			<ul style="list-style-type: none"> For warranty or service issues kindly contact brand support 		
D	Electro-cardiogram (ECG) Machine (sample model)		<p>12 Channel ECG Machine with display, High resolution backlit LCD screen, detailed 12lead ECG measurement and interpretation software, Multiple print formats from integrated 12channel thermal printer on A4size thermal paper, 12lead rhythm printout on single A4 Page, Alpha-numeric key board with direct function keys for routine operation, on board memory to store 40ECG recordings, mains and battery operated, battery capacity up to 300ECG printouts or 4hrs of normal use.It includes ECG leads/pad</p>	2	Nos
E	Sphygmomanometer, mercury free type desk model – portable (sample model)		<ul style="list-style-type: none"> MERCURY FREE - The BP monitor has an LED backlit mercury-free LCD Display digital scale . The panel allows for automatic and semi-automatic measurement of systolic & diastolic BP and pulse rate. DUAL MODE - AUTO & MANUAL MODE: Provides dual-mode measurement with or without a stethoscope. Switch on the BP using the 'Auto' button for Automatic mode measurement - without a stethoscope. Simply inflate manually & wait for automatic deflation. Manual mode measurement can be taken with a stethoscop (like a conventional BP Monitor) by switching on the BP using the manual button. ACCURACY & WARRANTY - High-quality LCD with LED backlight and high-quality semiconductor sensors ensure accuracy. Manual inflation and automatic deflation.This device comes with a 1-Year warranty. PORTABLE METAL BOX & POWER SOURCE - Silver metallic powder-coated metal body. The devic ecan be powered with the provided electric adapter or 3 x AAA batteries. LICENSED MANUFACTURERS- LifeLine Medical Devices are ISO 13485 certified & CDSCO licensed manufacurers of medical devices estd. in 1986. The BP instrument is manufactured using first-grade quality components assuring reliable, accurate, and calibrated readings. 	20	Nos
F	Teaching stethoscope (sample model)		<p>Teaching stethoscope is good for traning and teaching Purpose .It can simultaneously use two person This stethoscope is use for educational traning ., There are two binaural, a Y connector, two pieces of Y-tubing and an extension tube which come in a single set of teaching.Extra 40" length and two headsets for simultaneous auscultation Two sided chest piece Comfortable fit Optimal sound transmission Durable</p>	20	No

APPENDIX - D

REVISED SECTION-6 FOR PACKAGE 0146

SERIAL NO	ITEM	PICTURE	SPECIFICATION	QUANTITY	UNIT
G	Stethoscope (Basic) (sample model)		Machined stainless steel chest piece, Diaphragm Diameter 4.5 cm (1.75 Inch approx) & Bell Diameter 3.2 cm (1.25 Inch approx), Spare diaphragm & soft ear tips provided absolutely free of cost, Reliable & High Acoustic Sensitivity offer an advantage to Health Care Professionals when listening to Heart, Lung and Blood Pressure Sounds	20	No
H	Pen Torch (sample model)		<ul style="list-style-type: none"> · Easy to carry · Comes with White light · Equipped with LED technology 	10	Nos
I	Hypocount set (glucometer) (sample model)		<ul style="list-style-type: none"> · MONITOR & CONTROL DIABETES : BeatO Curv Glucometer is more than a mobile blood sugar testing machine. It is designed to help you monitor, manage & control your sugar levels with ease under the guidance of doctors & experts. · USB CONNECTED, NEEDS NO BATTERIES : BeatO Smartphone Connected glucometer connects to your USB charging port and needs no batteries or charging. Test your sugar level with the BeatO Curv glucometer using BeatO Curv sugar testing strips and get accurate results with insights within seconds. · AUTOMATICALLY SAVE READINGS : No more writing down your sugar levels! BeatO Curv auto saves all your sugar readings on the BeatO App and cloud. You can always have a record handy on your smartphone. · SMALL & EASY TO USE : Diabetes management made easy! BeatO Curv Glucometer, your all-in-one sugar test machine is super easy to use. It's coin-sized and can be carried anywhere, helping you monitor easily at any time. · SHARE READINGS WITH YOUR DOCTOR : Easily share your blood glucose reading record from the BeatO App with your doctor or loved ones and keep them informed. The doctors can analyse your readings and suggest the right diabetes medicine for you. · ACCURATE & ISO CERTIFIED: Made In India, ISO CERTIFIED · WORKS WITH FEATURE RICH BEATO APP : BeatO Curv works seamlessly with the BeatO App which provides advanced features for comprehensive diabetes management. This includes adding notes, personalized insights, graph based trends & ability to share readings. 	5	Nos



APPENDIX - D

REVISED SECTION-6 FOR PACKAGE 0146

SERIAL NO	ITEM	PICTURE	SPECIFICATION	QUANTITY	UNIT
A	Linen push trolley (sample model)		Easily Adjustable, High, Strength, Durable, Stain, Resistance, Elegant Design, Easy To Maintain, Customized Usability.	3	Nos
B	Dressing trolley, Rectangle (sample model)		Load Capacity: 0-50 kg Cart Size: 32" L X 24"W X 36"H Max Height: 3 Feet Condition: New No. Of Shelves: 2	10	Nos
C	Square trolley, 2 shelves (sample model)		Framework Made of 18 Gauge Of Stainless Steel Tubes Mounted On 7.5 cms Castors. Two Platform S.S. Shelves Made Up Of 18 Gauge Stainless Steel Sheet With Three Side Railing SS Railing On Both Shelf. Available With Two Shelves. Heavy Duty Instrument Trolley Use For Hospital & Workstation Silent Castors With The Availability Of Two Brake In The Castors. All SS Rectangular Frame Mounted Below The Platform Sheets To Give The High Load-Bearing Capacity And Finish. Complete Non Sharpening Edge In The Trolley. It Is Used By Prestigious Hospitals Chains In India. Warranty One Year Dimension (LxDxH) Is 24 (Length) x 18 (Depth) x 36 Inch (Height)	10	Nos
D	Sponging trolley (sample model)		Framework Made of 18 Gauge Of Stainless Steel Tubes Mounted On 7.5 cms Castors. Two Platform S.S. Shelves Made Up Of 18 Gauge Stainless . It Is Used By Prestigious Hospitals Chains In India. Warranty One Year Dimension (LxDxH) Is 24 (Length) x 18 (Depth) x 36 Inch (Height)	8	Nos
E	Round linen trolley (sample model)		Easily Adjustable, High, Strength, Durable, Stain, Resistance, Elegant Design, Easy To Maintain, Customized Usability	6	Nos





APPENDIX - D

REVISED SECTION-6 FOR PACKAGE 0146

SERIAL NO	ITEM	PICTURE	SPECIFICATION	QUANTITY	UNIT
F	3-Tier Multi-Purpose Trolley (sample model)		<p>Framework Made of 18 Gauge Of Stainless Steel Tubes Mounted On 7.5 cms Castors.</p> <p>Three Platform S.S. Shelves Made Up Of 18 Gauge Stainless .</p> <p>It Is Used By Prestigious Hospitals Chains In India.</p> <p>Warranty One Year</p> <p>Dimension (LxDxH) Is 24 (Length) x 18 (Depth) x 36 Inch (Height)</p>	10	Nos
10	WALKING / TRANSPORTATION AID				
A	Wheelchair, S/S, detachable (sample model)		<p>WheelEasy is the perfect wheelchair for all mobility needs. The sturdy frame and EVA wheels make it the perfect option for those in need. It is foldable, with rexine upholstery which makes it easy to transport and clean it. Equipped with seatbelt and rear-wheel locks offering the highest degree of safety. A reliable everyday transit wheelchair with best-in-class quality.</p> <p>Seatbelt for Safety</p> <p>Weight capacity- Upto 125 Kgs</p> <p>3 year warranty</p> <p>Durable Frame</p> <p>Seat Width-19"inch</p> <p>Rear-wheel locks</p>	4	No
B	Geriatric chair (sample model)		<p>is a padded, supportive reclining chair designed for home or in-hospital use. It is designed to allow elderly patients or individuals recovering from surgery or illness to sit comfortably in their room or while being transported. Geri chairs are an excellent alternative to sitting in bed.</p>	4	Nos
C1	Crutches, Axilla, youth		<p>Crutches, Axilla, Youth :</p> <p>Axilla Crutch (Pair) is a designed to facilitate mobility during recovery, post-operative care, disability, fracture or injury to the lower extremities. According to the severity of injury it is can be used for permanent or temporary period of time in non-weight bearing conditions.</p>	5	Nos
C2	Crutches, Axilla, adult		<p>Axilla Crutch (Pair) is a designed to facilitate mobility during recovery, post-operative care, disability, fracture or injury to the lower extremities. According to the severity of injury it is can be used for permanent or temporary period of time in non-weight bearing conditions.</p>	5	Nos







APPENDIX - D

REVISED SECTION-6 FOR PACKAGE 0146

SERIAL NO	ITEM	PICTURE	SPECIFICATION	QUANTITY	UNIT
D	Patslide (sample model)		<p>Size: H1525mm x L635mm x W10mm Weight: 4.8 kg ,Patient Safety and Comfort: The PATSLIDE® is designed to enhance patient safety and comfort during transfers. Its smooth upper surface provides low resistance, allowing for easy movement. Bridges Gaps: It spans the gaps that occur between beds, trolleys, and tables, creating a smooth bridge for patients during transfers. Flexibility: The PATSLIDE® flexes to facilitate patient movement, making it easier for both patients and healthcare staff. No Sharp Edges: The slide has no sharp edges or protrusions, ensuring safety during use. Easy to Clean: Made from a specially formulated thermoplastic, the PATSLIDE® is easily cleaned by washing with detergent or any other aqueous-based disinfectant. Weight Capacity: While it is not weight-bearing, the PATSLIDE® is rated to support up to 250 kg</p>	4	Nos
E	Walking stick (sample model)		<p>Walking Stick with Adjustable Height Level is designed to provide exceptional support and stability for older .Strong and heavy-duty walking cane offers a sleek and sturdy construction. The comfortable hand grip ensures a firm hold, while the ergonomic design reduces strain on your back, shoulder, and wrist.</p>	5	Nos
G	Transfer Belt (sample model)		<p>SOFT AND COMFORTABLE PADDED HANDLES - The belts transfer belts with soft handles at different angles should provide with all-round angles of grip, so it is easy to get a good grip from any side. Multiple handles support for Patient more safe, (for 33.5"-55" Waist) ANTI-SLIP & WIDEN DESIGN – Six inches wide, wrapping a larger area around the patients' waist, more comfort when walking and transferring. Soft and breathable</p>	5	Nos
H	Walking frame adjustable ad foldable (sample model)		As per health care industry standard	5	Nos
I	Standing transfer Aid (sample model)		As per health care industry standard	2	No
11	LINEN				

APPENDIX - D

REVISED SECTION-6 FOR PACKAGE 0146

SERIAL NO	ITEM	PICTURE	SPECIFICATION	QUANTITY	UNIT
A	Adult blanket (sample model)		Super Soft Single Blanket Dimensions: 60"x 90" inches. Perfect for Single bed	20	No
B	Pillow (adult)		Microfiber Pillow Filler, 16X24 Inch, White,	20	No
C	Pillow case		NonWoven Pillow Cover for Hospitals, 24x17 Inches	20	No
D	Bath towel		Cotton Face and Body Towel for Hospital, Hotel, Travelling Large Reusable and Compressed Bath Towel	40	No
E	Pajamas for females & males (S, M, L)		UNISEX PATIENT DRESS ;FRONT TIES TOP AND LOWER (DARK BLUE)	80	No
F	Sarong		PIU Hospital Patient Pure Cotton Unisex Gown	10	No
G	Orthopaedic trousers		Patient Gown For Adult, Hospital Gown, Cotton, 3 Back ties, Patient care (Blue Checks) Universal Size	10	No
H	White / green gown		Get Well Health Pure Cotton Patient Gown Women/Men/Unisex Back Open Universal Size Hospital Gown	10	No
I	Dressing towel (sample model)		White colour cotton towel	20	No
J	Face flannel (sample model)		Cotton face ,adult one colour-blue/green	10	No
K	Face flannel wash gloves in shape of pocket 16cm X 24cm (pkt of 100) (sample model)		gloves in shape of pocket 16cm X 24cm (pkt of 100) white in colour	1	No
L	Mackintosh (sample model)		Rubber one -Mackintosh	6	Nos
M	Linen carrier bag / canvas (sample model)		As per health care industry standard	5	Nos

APPENDIX - D

REVISED SECTION-6 FOR PACKAGE 0146

SERIAL NO	ITEM	PICTURE	SPECIFICATION	QUANTITY	UNIT
N	Restrainer (body, limbs, mitten) (sample model)		As per health care industry standard	20	Nos
12	CONSUMABLES				
A	Alcohol swab (in sachet)		Alcohol swab (in sachet) (1packet contain 100pcs) Minimum	10	Packets
B	Apron, disposable, plastic 100's		Apron, disposable, plastic 100's (1packet contain 100pcs)Minimum	4	Packets
C	Bag, polythene 102mm X 178mm X 0.02mm clear		polythene Bag, 178mm X 102mm X 0.02mm (length*width*thickness) minimum	2	Packets
D	Bag, polythene 203mm X 254mm X 0.02mm clear		Bag, polythene 203mm X 254mm X 0.02mm (length*width*thickness) minimum	2	Packets
E	Bag, polythene 305mm X 457mm X 0.02mm clear		Bag, polythene 305mm X 457mm X 0.02mm clear (length*width*thickness) minimum	2	Packets
F	Bag, polythene, black, size 635mm X 865mm X 0.08mm thick (pkt X 100pc)		Bag, polythene, black, size 635mm X 865mm X 0.08mm thick (pkt X 100pc) Minimum	2	Packets
G	Bag, polythene, white with double-sided self-adhesive tape (pkt X 100pc)		Bag, polythene, white with double-sided self-adhesive tape (pkt X 100pc) (length*width*thickness) minimum	2	Packets
H	Bag, polythene, yellow with double-sided self-adhesive tape (pkt X 100pcs)		Bag, polythene, yellow with double-sided self-adhesive tape (pkt X 100pcs) minimum	2	Packets
			1packet include 100pcs		
I	Bag, plastic yellow for bio-hazard waste with printing size big		Bag, plastic yellow for bio-hazard waste with printing size big	1	Packets 1packet include 500pcs
	(pkt X 500pcs)		(pkt X 500pcs) minimum		

APPENDIX - D

REVISED SECTION-6 FOR PACKAGE 0146

SERIAL NO	ITEM	PICTURE	SPECIFICATION	QUANTITY	UNIT
J	Bag, plastic yellow for bio-hazard waste with printing size small		Bag, plastic yellow for bio-hazard waste with printing size small	1	Packet
	(pkt X 500pcs)		(1pkt include 500pcs) minimum		
K	Bandage adhesive elastic 51mm width (2")		Bandage adhesive elastic 51mm (2") width (1roll) minimum length-4.0m minimum	40	Packets
L	Bandage adhesive elastic 76mm width (3")		Bandage adhesive elastic 76mm (3") width minimum	40	Packets
M	Bandage adhesive elastic 102mm width (4")		Bandage adhesive elastic 102mm (4")width minimum	40	Packets
N	Bandage cotton W.O.W 76mm width (3")		Bandage cotton W.O.W (White open weave) 76mm width (3") minimum length-5m (1roll)	20	Packets
O	Bandage cotton W.O.W 102mm width (4")		Bandage cotton W.O.W(White open weave) 102mm (4") width (Minimum)	20	Packets
P	Bandage cotton W.O.W 152mm width (6")		Bandage cotton W.O.W (White open weave) 152mm (6") width (Minimum)	20	Packets
Q	Bandage crepe BP 50mm X 4.57 mtr (2")		Bandage crepe BP((50mm (2") X 4.57 mtr) Minimum	40	Packets
R	Bandage crepe BP 76mm X 4.57 mtr (3")		Bandage crepe BP 76mm (3") X 4.57 mtr (Minimum)	40	Packets
S	Bandage crepe BP 102mm X 4.57 mtr (4")		Bandage crepe BP 102mm (4") X 4.57 mtr (Minimum)	40	Packets
T	Bandage crepe BP 152mm X 4.57 mtr (6")		Bandage crepe BP 152mm (6") X 4.57 mtr (Minimum)	40	Packets
U	Bandage P.O.P. 102mm X 2.74 mtr (4")		Bandage P.O.P (plaster of paris). 102mm X 2.74 mtr (4" width) (Minimum)	40	Packets
V	Bandage P.O.P. 152mm X 2.74 mtr (6")		Bandage P.O.P. 152mm X 2.74 mtr (6") minimum	40	Packets

APPENDIX - D

REVISED SECTION-6 FOR PACKAGE 0146

SERIAL NO	ITEM	PICTURE	SPECIFICATION	QUANTITY	UNIT
W	Bandage Triangular Calico B.P. 914mm		Bandage Triangular B.P 914mm (96cm * 135cm) (Minimum)	100	Packets
X	Blade surgical Bard Parker sterile no. 10 (Disposable)		Blade surgical Bard Parker sterile no. 10 (Disposable) (Minimum)	2	Packets
Y	Blade surgical Bard Parker sterile no. 15 (Disposable)		Blade surgical sterile no. 15 (Disposable) (1packet-50pcs) (Minimum)	2	Packets
Z	Blade surgical Bard Parker sterile no. 21 (Disposable)		Blade surgical sterile no. 21 (Disposable) (Minimum)	2	Packets
AA	Cap white/green/blue free size (100pcs/pkt)		Cap white/green/blue free size (100pcs/pkt) (Minimum)	1	Packets
AB	Cannula intravenous, size 18 G sterile, disposable		Cannula intravenous, size 18 G sterile, disposable (Minimum)	1	Packets
AC	Cannula intravenous, size 22 G sterile, disposable		Cannula intravenous, size 22 G sterile, disposable (Minimum)	1	Packets
AD	Cannula intravenous, size 24 G sterile, disposable		Cannula intravenous, size 24 G sterile, disposable (Minimum)	1	Packets
13	CATHETERS				
A	Catheter foley's 2 way sterile, disposable rubber size 10CH 10/box		Catheter foley's 2 way sterile, disposable rubber size 10CH 10/box (Minimum)	5	Box
B	Catheter foley's 2 way sterile, disposable rubber size 12FG		Catheter foley's 2 way sterile, disposable rubber size 12FG (Minimum)	5	Box
C	Catheter foley's 2 way sterile, disposable rubber size 14FG		Catheter foley's 2 way sterile, disposable rubber size 14FG (Minimum)	10	Box
D	Catheter foley's 2 way sterile, disposable rubber size 16FG		Catheter foley's 2 way sterile, disposable rubber size 16FG (Minimum)	5	Box
E	Catheter foley's 2 way sterile, disposable rubber size 18FG		Catheter foley's 2 way sterile, disposable rubber size 18FG (Minimum)	5	Box

APPENDIX - D

REVISED SECTION-6 FOR PACKAGE 0146

SERIAL NO	ITEM	PICTURE	SPECIFICATION	QUANTITY	UNIT
F	Catheter foley's 3 way sterile, disposable rubber size 18FG		Catheter foley's 3 way sterile, disposable rubber size 18FG (Minimum)	5	Box
G	Catheter foley's 3 way sterile, disposable rubber size 20FG		Catheter foley's 3 way sterile, disposable rubber size 20FG (Minimum)	5	Box
H	Catheter foley's 3 way sterile, disposable rubber size 22FG		Catheter foley's 3 way sterile, disposable rubber size 22FG (Minimum)	5	Box
I	Catheter foley's 3 way sterile, disposable rubber size 24FG		Catheter foley's 3 way sterile, disposable rubber size 24FG (Minimum)	5	Box
J	Catheter suction PVC with finger tip control sterile, disposable, 8FG		Catheter suction PVC with finger tip control sterile, disposable, 8FG (Minimum)	1	Box
K	Catheter suction PVC with finger tip control sterile, disposable, 10FG		Catheter suction PVC with finger tip control sterile, disposable, 10FG (Minimum)	1	Box
L	Catheter suction PVC with finger tip control sterile, disposable, 12FG		Catheter suction PVC with finger tip control sterile, disposable, 12FG (Minimum)	1	Box
M	Catheter suction PVC with finger tip control sterile, disposable, 14FG		Catheter suction PVC with finger tip control sterile, disposable, 14FG (Minimum)	1	Box
N	Connector for tubing straight nylon 4 mm bore		Connector for tubing straight nylon 4 mm bore (Minimum)	10	Box
O	Connector tubing 'Y' shape, polypropylene, 7 mm bore		Connector tubing 'Y' shape, polypropylene, 7 mm bore (Minimum)	10	Box
P	Container for biohazard sharp disposable		Container for biohazard sharp disposable	10	Box
Q	Cotton balls absorbent white 0.5gm sterile (10 balls per pkt)		Cotton balls absorbent white 0.5gm sterile (10 balls per pkt) (Minimum)	50	Packets
R	Cotton wool balls size 1/2GM Medium (PKT X 100)		Cotton wool balls size 1/2GM Medium (1PKT contain 100 pcs) (Minimum)	10	Packets
S	Cover for bedpan, white paper disposable 32cm X 52cm		Cover for bedpan, white paper disposable 32cm X 52cm (confirm quantity) (Minimum)	10	Packets
T	Dressing sets Disposable		BIB TIE TYPE APRON WHITE or BLUE WATERPROOF APRON MADE WITH ADVANCED TECHNICAL FABRIC	200	Nos
14	INTRAVENOUS THERAPY				
A	Drip set I.V. administration without filter, sterile, disposable, 10's		Drip set I.V. administration without filter, sterile, disposable, 10's (1packet contain10pcs)	5	Box

APPENDIX - D

REVISED SECTION-6 FOR PACKAGE 0146

SERIAL NO	ITEM	PICTURE	SPECIFICATION	QUANTITY	UNIT
B	Drip set I.V. administration infusion 15 drops, sterile, disposable, 50's		Drip set I.V. administration infusion 15 drops, sterile, disposable, 50's (1packet contain10pcs)	5	Box
C	Drip set I.V. administration infusion 60 drops, sterile, disposable		Drip set I.V. administration infusion 60 drops, sterile, disposable (1packet contain10pcs)	10	Box
D	Drip set I.V. administration paediatric (micro drip set), sterile, disposable		Drip set I.V. administration paediatric (micro drip set), sterile, disposable (1packet contain10pcs)	10	Box
E	Drip set I.V. blood administration, complete, sterile, disposable		Drip set I.V. blood administration, complete, sterile, disposable (1packet contain10pcs)	10	Box
F	Elastoplast/band aid 100's		Elastoplast/band aid 100's (1packet contain10pcs)	2	Box
G	Electrode disposable for ECG monitoring pre-gelled adult size 68mm dia		Electrode disposable for ECG monitoring pre-gelled adult size 68mm dia -Minimum (1 box contain 100pcs) Minimum	1	Box
H	Gauze swab, sterile, white, 4 ply size 75mm X 75mm (5 pcs per pkt)		Gauze swab, sterile, white, 4 ply size 75mm X 75mm (5 pcs per pkt) Minimum	50	Box
I	Gauze absorbent BPC 914mm X 5.49 mtr-non-sterile, 100pkt		Gauze absorbent BPC 914mm X 5.49 mtr-non-sterile, 100pkt Minimum	5	Box
J	Gauze BPC precut and folded 16 ply 75mm X 75mm (pkt X 100) – non-sterile		Gauze BPC precut and folded 16 ply 75mm X 75mm (pkt X 100) – non-sterile Minimum	5	Box
K	Gauze BPC precut and folded 32 ply 75mm X 75mm (pkt X 100) – non-sterile		Gauze BPC precut and folded 32 ply 75mm X 75mm (pkt X 100) – non-sterile Minimum	5	Box
L	Gloves examination, latex, non-sterile, large, 100 pcs/box		(3-4 equivalent brand names)Gloves examination, latex, non-sterile, large, 100 pcs/box (Minimum)	5	Box
M	Gloves examination, latex, non-sterile, medium, 100 pcs/box		Gloves examination, latex, non-sterile, medium, 100 pcs/box (Minimum)	5	Box

APPENDIX - D

REVISED SECTION-6 FOR PACKAGE 0146

SERIAL NO	ITEM	PICTURE	SPECIFICATION	QUANTITY	UNIT
N	Gloves examination, latex, non-sterile, small, 100 pcs/box		Gloves examination, latex, non-sterile, small, 100 pcs/box (Minimum)	5	Box
O	Gloves polythene, non-sterile, disposable, medium 100pcs/box		Gloves polythene, non-sterile, disposable, medium 100pcs/box (Minimum)	10	Box
P	Gloves polythene, non-sterile, disposable, large 100pcs/box		Gloves polythene, non-sterile, disposable, large 100pcs/box (Minimum)	10	Box
Q	Gloves polythene, sterile, disposable, medium 100pcs/box		Gloves polythene, sterile, disposable, medium 100pcs/box (Minimum) (1box contain 10pcs)	10	Box
R	Gloves surgical, latex, sterile, size 5 ½ 40/box		Gloves surgical, latex, sterile, size 5 ½ 40/box (Minimum)	10	Box
S	Gloves surgical, latex, sterile, size 6		Gloves surgical, latex, sterile, size 6 (Minimum)	10	Box
T	Gloves surgical, latex, sterile, size 6 ½		Gloves surgical, latex, sterile, size 6 ½ (Minimum)	10	Box
U	Gloves surgical, latex, sterile, size 7		Gloves surgical, latex, sterile, size 7 (Minimum)	10	Box
V	Gloves surgical, latex, sterile, size 7 ½		Gloves surgical, latex, sterile, size 7 ½ (Minimum)	10	Box
W	Gloves surgical, latex, sterile, size 8		Gloves surgical, latex, sterile, size 8 (Minimum)	5	Box
X	Gloves sterile, individual pack, size 6 & 7		Gloves sterile, individual pack, size 6 & 7 (Minimum)	20	Box
Y	Incontinent pad disposable size 440mm X 610mm 300's		Incontinent pad disposable size 440mm X 610mm 300's (Minimum)	1	Box
AA	Universal pH paper		Universal pH paper (1box contain 10pcs)	10	Box
AB	Mask disposable paper, tie-on 3 ply (Box X 100 pcs)		Mask disposable paper, tie-on 3 ply (1 box contain 100 pcs)	2	Box
AC	Mask disposable surgical, high filter 3 ply size 18cm X 9cm		Mask disposable surgical, high filter 3 ply size 18cm X 9cm minimum	10	Box
AD	Mask aerosol Non-rebreather mask, adult size		Mask aerosol Non-rebreather mask, adult size (1 box contain 25 pcs)	20	Box
AE	Mask aerosol Simple face mask, adult size		Mask aerosol Simple face mask, adult size (1 box contain 25 pcs)	20	Box
AF	Mask oxygen Nebulizer Mask, adult size		Mask oxygen Nebulizer Mask, adult size (1 box contain 25 pcs)	10	Box
AG	Mask oxygen PVC, multi-vent with selector, adult size		Mask oxygen PVC, multi-vent with selector, adult size (1 box contain 10 pcs)	10	Box
AH	Mouth piece disposal for peak flow meter adult 100's		Mouth piece disposal for peak flow meter adult 100's Minimum	1	Box

APPENDIX - D

REVISED SECTION-6 FOR PACKAGE 0146

SERIAL NO	ITEM	PICTURE	SPECIFICATION	QUANTITY	UNIT
AI	Nasal cannula (oxygen) 2-prong, adjustable, 2100mm long		Nasal cannula (oxygen) 2-prong, adjustable, 2100mm long Minimum	20	Box
15	NEEDLES				
A	Needles hypodermic, sterile, disposable size 19G X 38mm (Box X 100)		Needles hypodermic, sterile, disposable size 19G X 38mm (Box X 100) Minimum	1	Box
B	Needles hypodermic, sterile, disposable size 21G X 38mm (Box X 100)		Needles hypodermic, sterile, disposable size 21G X 38mm (Box X 100) Minimum	1	Box
C	Needles hypodermic, sterile, disposable size 23G X 38mm (Box X 100)		Needles hypodermic, sterile, disposable size 23G X 38mm (Box X 100) Minimum	1	Box
D	Needles hypodermic, sterile, disposable size 25G X 38mm (Box X 100)		Needles hypodermic, sterile, disposable size 25G X 38mm (1 box contain 100 pcs) Minimum	1	Box
E	Oral toilet set, disposable		Tooth brush, tongue cleaner, oral suction set	50	Box
F	M-Fold paper towel (pkt X 50 sheets)		M-Fold paper towel (1 pkt contain 50 sheets) Minimum	2	Box
G	Pin safety assorted size (pkt X 12 pcs)		Pin safety assorted size (1 pkt contain 12 pcs) Minimum	10	Box
H	Sheath penile, urine condom size 25mm X 78mm 100's		Sheath penile, urine condom size 25mm X 78mm 100's Minimum	1	Box
I	Sheath penile, urine condom size 30mm X 93mm		Sheath penile, urine condom size 30mm X 93mm Minimum	1	Box
J	Spigot, polypropylene size 7mm X 31mm LTH		Spigot, polypropylene size 7mm X 31mm LTH Minimum	10	Box
K	Stockinette 5cm X 20m		Stockinette 5cm X 20m Minimum	5	Box
L	Stocking – Anti-embolic, various size (12/box)		Stocking – Anti-embolic, various size (1 box contain 12 pcs)	1	Box
M	Stopcock 3 way (sample model)		As per healthccare industry standard	1	No
N	SYRINGES (routine consumables)				
O	Syringe sterile, disposable 1ml, 100's		Syringe sterile, disposable 1ml, 100's Minimum	1	Box
P	Syringe sterile, disposable 3ml, 100's		Syringe sterile, disposable 3ml, 100's Minimum	1	Box
Q	Syringe sterile, disposable 5ml, 100's		Syringe sterile, disposable 5ml, 100's Minimum	1	Box
R	Syringe sterile, disposable 10ml, 100's		Syringe sterile, disposable 10ml, 100's Minimum	1	Box
S	Syringe sterile, disposable 20ml, 40's		Syringe sterile, disposable 20ml, 40's Minimum	2	Box
T	Syringe sterile, disposable 60ml, 30's		Syringe sterile, disposable 60ml, 30's Minimum	2	Box
U	Syringe insulin, sterile, disposable 100 unit/ml, 100's		Syringe insulin, sterile, disposable 100 unit/ml, 100's Minimum	1	Box

APPENDIX - D

REVISED SECTION-6 FOR PACKAGE 0146

SERIAL NO	ITEM	PICTURE	SPECIFICATION	QUANTITY	UNIT
V	Solutions (antiseptic, sterile water & saline, plaster removal etc)		Solutions (antiseptic, sterile water & saline, plaster removal etc) -5 box from each solution Minimum	20	Box
W	Swab stick (Sodium Bicarbonate/Plain) 100pcs/box		Swab stick (Sodium Bicarbonate/Plain) 1 box contain 100pcs Minimum	1	Box
16	TAPES Red are consumables				
A	Measuring Tape		Measuring Tape (1.5meter with each centimeter) Minimum	5	No
B	Surgical microporous adhesive size 12.7mm X 9.14m ½ inch		Surgical microporous adhesive size 12.7mm X 9.14m ½ inch Minimum (1box 10pcs)	4	Box
C	Surgical microporous adhesive size 25.4mm X 9.14m 1 inch		Surgical microporous adhesive size 25.4mm X 9.14m 1 inch Minimum (1box 10pcs)	4	Box
D	Surgical microporous adhesive size 50.8mm X 9.14m 3 inch		Surgical microporous adhesive size 50.8mm X 9.14m 3 inch Minimum (1box 10pcs)	4	Box
E	Feeding/Ryles PVC sterile disp., size 10FG		Feeding/Ryles PVC sterile disp., size 10FG (1box contain 25pcs)	4	Box
F	Feeding/Ryles PVC sterile disp., size 12FG		Feeding/Ryles PVC sterile disp., size 12FG (1box contain 25pcs)	4	Box
G	Feeding/Ryles PVC sterile disp., size 14FG		Feeding/Ryles PVC sterile disp., size 14FG (1box contain 25pcs)	4	Box
H	Feeding/Ryles PVC sterile disp., size 16FG		Feeding/Ryles PVC sterile disp., size 16FG (1box contain 25pcs)	4	Box
I	Feeding/Ryles PVC sterile disp., size 18FG		Feeding/Ryles PVC sterile disp., size 18FG (1box contain 25pcs)	4	Box
J	Feeding/Ryles PVC sterile disp., size 20FG		Feeding/Ryles PVC sterile disp., size 20FG (1box contain 25pcs)	4	Box
L	Traction set, non-adhesive		Traction set, non-adhesive	5	No
M	Traction set, adhesive		Traction set, adhesive	2	No
N	Urine bag (adult)		Urine bag (adult)	20	Pcs
17	CROCKERY				
A	Crockery Meal Trays		Crockery Meal Trays -Ceramic one	2	Sets
	- meal trays (5 pcs each)		- meal trays (5 pcs each)		
	- dinner plate (5 pcs each)		- dinner plate (5 pcs each)		
	- cereal bowl (5 pcs each)		- cereal bowl (5 pcs each)		
	- teacup & saucer (5 pcs each)		- teacup & saucer (5 pcs each)		
	- side plate (5 pcs each)		- side plate (5 pcs each)		
	- different types of spoons, knives & forks (5 pcs each)		- different types of spoons, knives & forks (5 pcs each)		
	- salt & pepper shakers (5 pcs each)		-salt & pepper shakers (5 pcs each)		
18	DOMESTIC ITEMS				

APPENDIX - D

REVISED SECTION-6 FOR PACKAGE 0146

SERIAL NO	ITEM	PICTURE	SPECIFICATION	QUANTITY	UNIT
A	Bin – sack holder (Step)sample model		Bin – sack holder (Step)	6	Box
B	Bin plastic with cover capacity 45 L		Bin plastic with cover capacity 45 L Minimum	2	Box
C	Clipper nail chrome plated approximately 6cm		Clipper nail chrome plated approximately 6cm Minimum	2	Packet
D	Cloth sponge for utensils		Cloth sponge for utensils	10	Packet
E	Cloth for cleaning floor/ tables/ chairs/ beds/ windows		Cloth for cleaning floor/ tables/ chairs/ beds/ windows	50	Packet
F	Cleaning agents , Dettol)		Cleaning agents , Dettol)	10	Packet
G	Paper serviettes twin ply, white size (pkt X 50 sheets)		Paper serviettes twin ply, white size (pkt X 50 sheets)Minimum	5	Packet
H	Powder, baby talcum		Powder, baby talcum	5	Packet
I	Razor set for shaving disposable (10/pkt)		Razor set for shaving disposable (10/pkt)Minimum	5	Packet
J	Soap liquid for body wash		Soap liquid for body wash	5	Packet
K	Soap liquid, hand		Soap liquid, hand	5	Packet
L	Shampoo		Shampoo	5	Packet
M	Sponge (for cleaning crockery)		Sponge (for cleaning crockery)	10	Packet
N	Straw drinking plastic (pkt X 100 pcs)		Straw drinking plastic (pkt X 100 pcs)	2	Packet
O	Torchlight 3 cell capacity		Torchlight 3 cell capacity	2	Packet
P	Trash bags		Trash bags	20	Packet
19	MISCELLANEOUS				

APPENDIX - D





REVISED SECTION-6 FOR PACKAGE 0146

SERIAL NO	ITEM	PICTURE	SPECIFICATION	QUANTITY	UNIT
A	Wall Clock (sample model)		Wall Clocks- Battery Operated Large Wall Clock with Stereoscopic Dial Backlight, Ultra-Quiet Movement Quartz for Office ,Classroom ,School	4	No.
B	Bedfast Rinser		Patient Aid Positioning Sheet with Handles 42" X 36" Made with a Double Layer for added Strength Transfer Sheet for Turning, Repositioning & Sitting up Washable Patient Positioning Sheet for Bedridden Patient	2	No
C	Denture container		Denture container	10	No
D	Hot/cold pack		Hot/cold pack	10	No
E	Kettle		Kettle	5	No
F	Mortuary shroud		Mortuary shroud	6	No
G	Water pitcher (JUG)		Water pitcher (JUG)	5	No
H	Hypocount device		Hypocount device	8	No
I	Test strips blood glucose		Test strips blood glucose	4	Packets
J	Mask Fit Tool Kit		Mask Fit Tool Kit	2	No
K	Face Shield		Face Shield	50	No
L	Pill cutter		Pill cutter	2	No
M	Contactless dustbin		Contactless dustbin	4	No

WSC HCA / TRAINING MODELS/SIMULATORS







APPENDIX - D

REVISED SECTION-6 FOR PACKAGE 0146

SERIAL NO	ITEM	PICTURE	SPECIFICATION	QUANTITY	UNIT
20	TRAINING MODELS/SIMULATORS				
A	P10 Manikins (sample picture) (sample model)		As per health care industry standard	10	No
21	Teaching Model			1	No
A	SKELETONS AND ANATOMICAL MODELS (3B SCIENTIFIC) (sample model)		As per health care industry standard	2	No
	Fidelity & realism will be the priority				
B	Stan" standard skeleton-reinforced support, 170cm/7.58kg A10/5 (sample model)		As per health care industry standard This model is high quality and shows the skeleyons in anatomical detail	4	Nos
C	Heart, 4-part, 31x18x18cm G12 (sample model)		As per health care industry standard ,This model is high quality and shows the heart in anatomical detail	4	Nos







APPENDIX - D

REVISED SECTION-6 FOR PACKAGE 0146

SERIAL NO	ITEM	PICTURE	SPECIFICATION	QUANTITY	UNIT
D	Hypertension Model 34.5x11.5x11.5cm G35 (sample model)		As per health care industry standard This model is high quality and shows the hypertension moel in anatomical detail	2	Nos
E	Kidney with adrenal gland, 2 part 20x12x12cm K12 (sample model)		As per health care industry standard This model is high quality and shows the kidney in anatomical detail	4	Nos
F	Liver with gall bladder, pancreas and duodenum 4x20x18cm VE315 (sample model)		As per health care industry standard, This model is high quality and shows the liver in anatomical detail	4	Nos
G	Female pelvis, 2 part 41x31x20cm H10 (sample model)		As per health care industry standard This model is high quality and shows the female pelvis in anatomical detail	4	Nos
H	Male pelvis, 2 part 41x31x17cm H11 (sample model)		As per health care industry standard , This model is high quality and shows the male pelvis in anatomical detail	4	Nos
I	Unisex Torso, 11 part 92x42x25cm/4.6kg VA31 (sample model)		As per health care industry standard, This model is high quality and shows the unisex in anatomical detail	4	Nos
J	Torso 18 part (sample model)		As per health care industry standard, This model is high quality and shows the torso in anatomical detail	12	Nos



APPENDIX - D

REVISED SECTION-6 FOR PACKAGE 0146

SERIAL NO	ITEM	PICTURE	SPECIFICATION	QUANTITY	UNIT
K	Left Ear 4-part, 34x16x19cm E10 (sample model)		As per health care industry standard, This model is high quality and shows the left ear in anatomical detail	4	Nos
L	Eye 6-part, 9x9x15cm F15 (sample model)		As per health care industry standard, This model is high quality and shows the eye in anatomical detail	4	Nos
M	Brain model, 4 parts (sample model)		As per health care industry standard, This model is high quality and shows the head in anatomical detail	4	Nos
N	Intravenous Injection & Blood Sampling Arm (sample model)		As per health care industry standard, This model is high quality and shows the blood sampling arm in anatomical detail	2	Nos
O	Skin (sample model)		As per health care industry standard, This model is high quality and shows the skin in anatomical detail	4	Nos
P	BSE - Breast Self-Examination Model, 38x28x10cm/2.7kg W43005 (sample model)		1. Focus on learning on Clinical Breasts Examination and self-Breast examination. It should have an Identification of anatomical landmarks. It should be supplied with 1-wearable breast. Wearable breasts (includes left and right side of breast) should be of polyvinyl or silicone rubber, free from any hazardous materials for live wearable training. It should facilitate training on the examination of different breast pathologies including carcinomas (2cm, 3cm, 5 cm), cysts, fibrocystic diseases, and fibro adenoma. The material of manikin should withstand extremes of temperature (up to 50 degrees Celsius). BSE - Breast Self-Examination Model, 38x28x10cm/2.7kg W43005	5	Nos
Q	Catheterization model (these 2 model can be combined) (sample model)		1. The Catheterization and enema trainer should be a life-size, pelvis with upper thighs and interchangeable genitalia. 2. It should have realistic articulation that enables proper positioning while performing procedures. 3. Genitalia should be interchangeable with connectors and a urinary reservoir. It should facilitate both male and female urinary catheterization procedure. As per health care industry standard	20	Nos







APPENDIX - D

REVISED SECTION-6 FOR PACKAGE 0146

SERIAL NO	ITEM	PICTURE	SPECIFICATION	QUANTITY	UNIT
R	Ostomy Care model (sample model)		As per health care industry standard, This model is high quality and shows the ostomy care in anatomical detail	5	Nos
S	Chester Chest model (sample model)		As per health care industry standard, This model is high quality and shows the chest in anatomical detail	10	Nos
22	FURNITURE				
1	Patient Unit				
A	Motorized & Manually operated adult bed with attached drip-stand (sample pictures)		<p>Motor with integrated control panel</p> <hr/> <p>Fully Motorised 4 Motor with Bi-lateral integrated control for nurse and patient.</p> <hr/> <p>Function: Back Raise, Knee Raise, Hi-Lo, Trendelenburg/Reverse Trendelenburg</p> <hr/> <p>Single Button Cardiac Chair, Emergency Electric and Manual CPR.</p> <hr/> <p>Caster: Four 125 mm non-rusting TENTE roller castors with central locking.</p> <hr/> <p>Side rail: 2 Pairs of HDPE safety side rails complies with IEC 1-2-52 Full length with handgrip for enhanced Patient safety/comfort.</p> <hr/> <p>Patient safety and comfort: Battery back-up with built in battery charger, Low bed</p> <hr/> <p>height of 350 mm (without mattress), Stress saver raise feature for patient comfort.</p> <hr/> <p>Accessories: High quality Anti Microbial, Fire Retardant, Water Proof 100 mm Mattress,</p> <hr/> <p>IV Pole - High Grade stainless steel. PF 1202A Bed side cabinet with drawer and facility to lock.</p> <hr/> <p>Model: Bed Side cabinet</p> <hr/> <p>Hospital Bedside Table, Size: 15 Inch X 36 Inch, height 36</p>	20	No





APPENDIX - D

REVISED SECTION-6 FOR PACKAGE 0146

SERIAL NO	ITEM	PICTURE	SPECIFICATION	QUANTITY	UNIT
B	Overhead table (sample picture)		Drive Medical Non-Tilt Top over bedside table can be easily raised and lowered into the desired position between 28"-45" which makes it perfect for users when reading, writing, or eating. This table has a premium walnut, wood-grain, and melamine laminate. Product Dimensions - 30" X 30" X 16" and Package Dimensions-33" X 22" X 6", Weight- 11kg, Plywood Color: White, H style base with 2" swivel casters, spring-loaded, locking handle to easy re-position and secure tabletop.	20 (as per bed number)	No
C	Bed side locker (sample picture)		As per health care industry standard	20	No
D	Wall panel above each bed complete with: (sample model)		As per health care industry standard	20	Set/Feet
-	Oxygen Outlet				
-	Vacuum Suction Outlet (dummy unit) or else gas supply has to be there.				
E	Connection of pipe (for 10 beds X 2 WSC HCA Wards)		As per health care industry standard	2	Set
F	Connection of vacuum suction (for 10 beds X 2 WSC HCA Wards)		As per health care industry standard	2	Set
			As per health care industry standard,196.8"L x 0.9"W MaterialPolyvinyl Chloride Mounting TypeCeiling Mounted		





APPENDIX - D

REVISED SECTION-6 FOR PACKAGE 0146

SERIAL NO	ITEM	PICTURE	SPECIFICATION	QUANTITY	UNIT
G	Cubicle curtain track with curtain and installation (sample model)		Maximum Weight 33 Pounds Blue in colour curtain Material Polyester Product Dimensions 96"L x 144"W , You only need to machine wash or hand wash it with water temperature below 80 °F. 【Application】 Widely used in nursing homes, clinics, medical rooms, , and can also be used as room partition curtains.	20	Set
H	Tablet Chairs (sample model)		Similar or closer to the size. MATERIAL: MESH & WITH MESH CUSHION, 5-Prong nylon base for stability. Twin Wheel heavy-duty swivel Castor for easy mobility under load. Twin Wheel heavy-duty swivel Castor for easy mobility under load. Seat Hot pressed ply wood with steel T-Nuts for rigid fastening with PP cover. Back is moulded Bright Bar with stitched Mesh Cloth. Quality tapestry. High density Moulded PU cushion. Colour: Will be confirmed at time of purchase. (Provide catalogue) Foldable writing shelf/board: 1 cm thick ply Wood, anti Termite,, wáter proof, stain proof, anti dust, strong material.	82 Class room for the batch size	No
A	Wash basin including installation complete with: Paper towel dispenser		Best for the hospital industry	2	Set
B	Customized cupboards for storage		Best for the hospital industry	2	Set
C	4-Tier Multi-purpose trolley (sample model)		As per health care industry standard	2	No
WSC HCA / Handwashing Training Bay (Ward 1 & 2)					
A	Stainless steel washbasin (below shows 3) (sample model)		As per health care industry standard	3 (one in each area	No
B	Swan neck tap with long lever (see above) (sample model)		As per health care industry standard	5 (each small group of 5 trainee)	No



APPENDIX - D

REVISED SECTION-6 FOR PACKAGE 0146

SERIAL NO	ITEM	PICTURE	SPECIFICATION	QUANTITY	UNIT
C	Stainless paper towel dispenser Available paper dispenser steel/ plastic/ equivalent (sample model)		As per health care industry standard	4	No
1.WSC HCA / Assisted Shower Area					
B	Customized linen cupboard		Earlier mentioned	2	Set
C	Shower Mixer		As per health care industry standard	4	Nos
D	Foldable shower seat		As per health care industry standard	4	Nos
E	Grab rail (for elderly / handicapped) (sample model)		As per health care industry standard	4	Nos
F	Wash basin complete with mirror (sample model)		As per health care industry standard	4	Set
G	Toilet Bowl (sample model)		As per health care industry standard	4	No
1.WSC HCA / CPR Awareness					
	Air viva (sample model)		As per health care industry standard	16	Nos
A	Bowl- large, plastic		Bowl- large, plastic	16	No
B	Disposable airway (Adult) (24/box) Pocket mask – 20 no		Disposable airway (Adult) (24/box) Pocket mask – 20 no	10	Box
C	Antiseptic Handrub (500 ml) (Routine consumable) (sample model)		Antiseptic Handrub (500 ml) (Routine consumable)	10	No

APPENDIX - D

REVISED SECTION-6 FOR PACKAGE 0146

SERIAL NO	ITEM	PICTURE	SPECIFICATION	QUANTITY	UNIT
D	Sodium hydrochloride tablets (0.5g) (Presept) (600/tub) (sample model)		Sodium hydrochloride tablets (0.5g) (Presept) (600/tub)	5	Tub
E	Disposal alcohol wipes (consumables available locally) (sample model)		Disposal alcohol wipes (consumables available locally) (1 packet contain 100pcs)	4	Packets
F	Plastic pail for soaking manikin parts (sample model)		Plastic one, with 5litre capacity	8	No
27	BCLS Training Models / Simulators				
A	Half Torso Resusci Manikin		1.Mannequin should be robust, life adult torso with realistic anatomy and response using simulated boluses. 2.The mannequin should allow for training to perform Heimlich Abdominal Thrust man oeuvre with simulated food boluses. The adult make torso should be supplied with simulated food boluses (2), talcum powder (1 bottle), tank top (1), carry case (1) and a use manual.	8	No
	AED TRAINERS – 8 NO				
	Heimlich Abdominal Thrust Maneuver Model/ Chocking - 2				
B	Teaching models			1	Lot
1.WSC HCA / WSC HCA Simulation and Isolation Room					
1	TV, 65inch (outside sim/iso room) (sample model)		<ul style="list-style-type: none"> - Resolution : 4K Ultra HD (3840 x 2160) Refresh Rate : 50 Hertz;Connectivity : 3 HDMI ports to connect set top box or gaming console 1 USB ports to connect hard drives or other USB devices Ethernet Wi-fi Bluetooth; Sound: 20W Output-2CH Powerful Speakers OTS Lite Adaptive Sound Dual Audio Support (Bluetooth) Buds Auto Switch - Smart TV Features : Supported apps: YouTube, etc. Screen mirroring Universal Guide Media Home Tap View Mobile Camera Support AI Speaker Easy Setup App Casting Wireless DeX SmartThings Smart Hub IoT Sensor Web Browser - Display : 4K Ultra HD Smart Panel Crystal Processor 4K Pur Color HDR 10+ Mega Contrast UHD Dimming 3-Side Bezel-less Motion Xcelerator Contrast Enhancer Filmmaker Mode 	2	No

APPENDIX - D

REVISED SECTION-6 FOR PACKAGE 0146

SERIAL NO	ITEM	PICTURE	SPECIFICATION	QUANTITY	UNIT
			<ul style="list-style-type: none"> · Warranty Information : 3 year comprehensive warranty on product · Water Resistance Level: Water Resistant; Connector Type: Hdmi bluetooth; Memory Storage Capacity: 8.0GB; Response Time: 6.0ms 		
2	Vital signs Monitor, Touch Screen (With portable stand) (sample model)		LCD with 5-wire resistive touchscreen, Battery operating time (new, fully charged), When patient conditions require close attention, switch from spot check to automatic (programmable) interval monitoring of critical vital signs. Monitor noninvasive blood pressure, SpO ₂ , pulse, CO ₂ and respiration rate	2	No
29	TRAINING MODELS/SIMULATORS				
1	Medium fidelity Simulators One is needed to teach life threatening situations		It should be a realistic manikin for training a wide range of nursing care, cardiac life support skills in prehospital traumatic emergencies with wireless instructor control and patient monitor.-Realistic life-size intubation trainer with a flexible tongue, arytenoid cartilage, epiglottis, vallecula, vocal cords, trachea, esophagus, and simulated lungs .-Head has neck opening and replaceable skin for practicing cricothyrotomy techniques.-Should be able to show different clinical conditions of pupils (normal, constricted, blown).-The following airway skills can be practiced: Endotracheal intubation, Nasotracheal intubation, Digital intubation, Oropharyngeal airway insertion ,Nasopharyngeal airway insertion, Bag Valve Mask Ventilation, Retrograde intubation, Lightwand intubation, Laryngeal Mask Airway insertion, Combitube insertion, Surgical cricothyrotomy, Needle cricothyrotomy, Suctioning techniques	1	No
31	AV system consists of			2	Nos
			<ol style="list-style-type: none"> 1. The system should be able to Automate, track and report on every aspect of activities 2. The system should be user-friendly and reliable. 3. The system should be able to reduce the workload of center's activities 4. It should capture and stream multiple angles of synced video. 5. It should capture patient data and real medical devices. 6. It should allow to Annotate, debrief, and assess. 7. It should be secure with cloud-based storage and playback. Allow control access by role, department, and organizations. 8. It should allow scheduling, self-enrollment, and center sign-in 9. It Should allow seamlessly integrated checklist and large-scale and automated OSCE (objective structured clinical examination) workflows; In-depth and customizable reporting; Flexible design and installation option; Synchronized capture of multiple camera angles; Simulator data capture and visualization; Medical device capture; Learner and faculty tracking and portfolios; Center should sign-in directs and tracks users; Video annotation and session self-reflection. 10. It should allow for debrief from anywhere using just a browser. 		

APPENDIX - D

REVISED SECTION-6 FOR PACKAGE 0146

SERIAL NO	ITEM	PICTURE	SPECIFICATION	QUANTITY	UNIT
1	<p>AUDIO VISUAL SYSTEM for SIMULATION ROOM. One unit of center management & debriefing system for WSC will facilitate recording, data capturing, small team training & creation of future course. The debriefing system contains the undermentioned equipment,AV System consists of-</p>		<p>11. It should provide learner, faculty and facility usage reports, it should allow for customizable scenarios, roles and permissions.</p> <p>12. The system should be flexible and scalable - one room or many.</p> <p>13. It should be secured, mobile-friendly and cloud-based.</p> <p>14. It should allow for courses and curriculum tracking.</p> <p>15. It should allow for resources and inventory management</p> <p>16. .It should allow automated OSCE exam flow with extensive reports.</p> <p>17. It should allow OSCE module for large-scale exams.</p> <p>18. It should allow Instructors to annotate sessions, leverage event and trend data, and administer learner self-reflection evaluations for a true 360-degree view during debriefing and when providing additional feedback to learners.</p> <p>19. The System should automatically track valuable information about program utilization such as total sessions, learner contact hours and recording hours.</p> <p>20. Reports can be filtered by scenario, organization, and locations.</p> <p>21. They can also be exported to Excel to share with other educators or administrators.</p> <p>Tenderer must submit a blueprint to design a solution and system to allow flexible switching and scalability for future expansion without massive integration and major hardware upgrading within 1 month from date of award.</p> <p>The solution of the AV System allows flexibility of display regardless of display resolutions with built-in Scaler that's automatically scales the in-coming Video signal to match the resolution of the particular display The system must come with the following items:</p> <ul style="list-style-type: none"> • Recorders X 2 nos. • Digital audio processor X 2 nos. • Wireless Microphone X 4 nos. • Power Amplifier X 2 nos. • Speaker system X 8 nos. • Encoders X 2 nos. and Decoders X 2 nos. • Managed network PoE switch X 3 no. • Patch terminal X 2 nos. • System controller X 2 sets • Wireless router X 2 nos. • System rack X 2 <p>All items must come with minimum 3 years on-site warranty .</p>		
2	Wireless cameras (sample model)		<p>CCTV: 2 Megapixel,30m View Distance,Ethernet Connectivity,NVR:16 Channel,Support for 16 Channel Camera Input support,H264 Video format,Resolution 1080p,HDD: 4TB,3.5 inch SATA,6 Gb/s,5400 RPM,256 MB Cache,Cabling:Cabling with all Accessories, Clipping, tagging, RJ heads with all material Required for installation</p>	2	nos
			<p>Each unit must come with at least:</p> <ul style="list-style-type: none"> • hardware based media signal recorder • the ability to live stream via RTSP & RTMP protocol • the feature to capture & records 2 X HDMI sources with audio in MP4 format 		

APPENDIX - D

REVISED SECTION-6 FOR PACKAGE 0146

SERIAL NO	ITEM	PICTURE	SPECIFICATION	QUANTITY	UNIT
3	Recorder (sample model)		<ul style="list-style-type: none"> • PIP/POP single & side by side view feature • login authentication • 1 TB SSD storage & support external storage • built-in OSD (ON SCREEN DISPLAY) 10 inch capacitive touch screen • web-based control • video codec : H.264 • bit rate : selectable 1-30Mbps • Input & Output : <ul style="list-style-type: none"> - HDMI input X 2 & HDMI output X 1 - RJ45 LAN/USB 3.0 X 1 each 	2	No
4	Digital Sound Processor		<ul style="list-style-type: none"> • Each unit must have: <ul style="list-style-type: none"> • 6 x mono mic / line input with phantom power & 4 x mono line output • digital sound processing 32/64 bits • built-in digital sound processing (DSP) tools • 1 processor per input and output • 1 anti-feedback processor per mic/line input 	2	No
5	Wireless Microphone		<p>Each unit must have:-</p> <ul style="list-style-type: none"> • IDA approve frequencies (470-698MHZ) • operating range of 30-100m • receiver dimension of within 190(W) x 40(H) x 130(D)mm <p>belt-pack with head-worn microphone or lavaier (clip-on mic) x 1</p>	2	No
6	Power Amplifier		<p>Each unit must:-</p> <ul style="list-style-type: none"> • have 2 X 100 watts @4 or 8ohms • be Energy star qualified • have class D Ripple Suppression • convection cooled, fan less operation • ultra low in-rush current, allows amplifier to power up immediately without overloading and surging • have power consumption of 14 watts to 45 watts • weight not more than 1.5KG Speaker system <p>Each unit must have:</p> <ul style="list-style-type: none"> • 6.5 inch woofer with ¾" ferrofluid cooled dome • tweeter with 8 inch deep composite back-can • a frequency range of 65Hz to 22 KHZ 	2	No

APPENDIX - D

REVISED SECTION-6 FOR PACKAGE 0146

SERIAL NO	ITEM	PICTURE	SPECIFICATION	QUANTITY	UNIT
			<ul style="list-style-type: none"> • at least 110 degrees conical dispersion • 65watts continuous / 130watts peak • 8 ohms or 70/100V Magnetic attached grille • Enclosure Type : Plenum rated, fire-resistant 		
7	In-ceiling flushed mount speakers (sample model)		The unit must have:	2	No
			<ul style="list-style-type: none"> • 1080p & 4K display resolution, co-exist on the same platform • embedded / de-Embedded audio support • USB to support touch screen • supports to Daisy chain for flexibility • EDID EXPERT Technology • support landscape or Portrait display • integrated to any 3rd party control system • the ability to allow administrator to create user accounts such that each user can only view and manage the Encoders & Decoders that have been assigned to them • the feature to allow any user or Administrator to use a web-browser either from a Tablet (IOS/ ANDROID) or PC to manage the encoders & decoders • the feature to allow user to preview input source from Tablet or PC to perform a drag and drop of input source to any output • the ability to allow only Administrator the rights to view and manage all the encoders & decoders • the function to allow administrator to send any request to any output • the function to allow administrator to activate the switching of any input to any output without the respective user to accept the request • video of maximum Data Rate of 100-300Mbps and HDMI (4K) HDCP compatible • audio of HDMI TYPE A and Mini Stereo Jack X 1 each • RJ45 for Encoder X 1 and RJ 45 for Decoder X 2 • control system of IR mini Jack X 1 and RS-232 : 1 terminal block, 3 pole, baud rate 19200, data bits - 8 stop bits, no parity and flow control • USB for encoders X 1 & USB for decoders X 2 • housed in an environment of: <ul style="list-style-type: none"> - Operating Temperature:0-40 degrees Celsius - Storage Temperature:-20 to 60 degrees Celsius - Humidity:0 to 80% RH, non-condensing • housed in a metal housing, weight less than 1 kg and dimensions of at least 130(L) X 100(W) X 29.6(H)mm 		
			<p>The unit must have:</p> <ul style="list-style-type: none"> • 1080p & 4K display resolution, co-exist on the same platform 		



APPENDIX - D

REVISED SECTION-6 FOR PACKAGE 0146

SERIAL NO	ITEM	PICTURE	SPECIFICATION	QUANTITY	UNIT
9	4K Video over IP Decoder		<ul style="list-style-type: none"> • embedded / de-Embedded audio support • USB to support touch screen • supports to Daisy chain for flexibility • EDID EXPERT Technology • support landscape or Portrait display • integrated to any 3rd party control system • the ability to allow administrator to create user accounts such that each user can only view and manage the Encoders & Decoders that have been assigned to them • the feature to allow any user or Administrator to use a web-browser either from a Tablet (IOS/ ANDROID) or PC to manage the encoders & decoders • the feature to allow user to preview input source from Tablet or PC to perform a drag and drop of input source to any output • the ability to allow only Administrator the rights to view and manage all the encoders & decoders • the function to allow administrator to send any input source to any output and to accept from the user in each of the labs to prevent sudden interruption to on-going lessons • the function to allow administrator to activate the switching of any input to any output without the respective user to accept the request • video of maximum Data Rate of 150-500Mbps and HDMI (4K) HDCP compatible • audio of HDMI TYPE A and Mini Stereo Jack X 1 each • RJ45 for Encoder X 1 and RJ 45 for Decoder X 2 • control system of IR mini Jack X 1 and RS-232 : 1 terminal block, 3 pole, baud rate 19200, data bits - 8 stop bits, no parity and flow control • USB for encoders X 1 & USB for decoders X 2 • housed in an environment of: <ul style="list-style-type: none"> - Operating Temperature:0-40 degrees Celsius - Storage Temperature:-20 to 60 degrees Celsius - Humidity:0 to 80% RH, non-condensing • housed in a metal housing, weight less than 1 kg and dimensions of at least 130(L) X 100(W) X 29.6(H)mm 	2	No
10	Network switch		<p>The unit must come with:</p> <ul style="list-style-type: none"> • 24 ports managed switch X 3 • PoE Power • embedded secure sockets layers (SSL) encryption • extensive access control list (ACLs) • advanced defence mechanism including dynamic resolution protocol (ARP) inspection, IP source guard and Dynamic Host Configuration Protocol (DHCP) snooping, detect and block deliberate network attacks • secure core technology • Private VLAN • Dos Attack prevention • 3 years Onsite warranty 	2	No





APPENDIX - D

REVISED SECTION-6 FOR PACKAGE 0146

SERIAL NO	ITEM	PICTURE	SPECIFICATION	QUANTITY	UNIT
			<ul style="list-style-type: none"> • combo ports of 2 X RJ45 Gigabit / 2 X SFP 		
11	HDMI/VGA faceplate via HD Base T (sample model)		3 years Onsite warranty	2	No
12	System Control		<p>Each set must come with:</p> <ul style="list-style-type: none"> • at least 16 ports controller with PoE • 4XRS 232 / 4XIR / 4XRelay / 4XGPO-IO • Ethernet RJ 45 X 1 • mini USB for firmware update X 1 • processor speed of 1GHz • at least 512MB Ram memory / 4GB Flash • not more than 0.5kg/5V DC, 2A • LED indication for each port and function <p>wireless tablet at least 9.5 inch wi-fi only for control system and 32GB X 1 • resolution of 2048 x 1536</p>	2	No
13	Touch Tablet (sample model)		6 GB RAM 128 GB ROM Expandable Upto 1 TB,26.95 cm (10.61 inch) Full HD Display,8.0 MP Primary Camera 8 MP Front,Android 12 Battery: 7700 mAh,Processor: Qualcomm Snapdragon SDM 6803	2	No
14	Wireless Router		<p>Each unit must come with:</p> <ul style="list-style-type: none"> • dual band gigabit router • 1200Mbps 802.11ac/ax • 2.4GHz 300Mbps / 5GHz 867Mbps • minimum external Antenna X 4 • built-in 4 ports 100/1000 Mbps Gigabit switch • minimum USB 2.0 X 1 • supports DHCP Server, DDNS, DMZ and port forwarding 	2	No
15	Equipment Rack for System		<p>The unit must come with:</p> <ul style="list-style-type: none"> • 2 mounted racks of 31U and 9U • 31U - at least dimensions of 600(W) X 800(D) X 31(U)mm • 9U - at least dimensions of 600(W) X 800(D) X 9(U)mm • tempered glass & lock 	2	No





APPENDIX - D

REVISED SECTION-6 FOR PACKAGE 0146

SERIAL NO	ITEM	PICTURE	SPECIFICATION	QUANTITY	UNIT
16	CCTV System			2	No
17	Installation & Programming			2	No
2	MISC				
A	Key Box (sample model)		Metal Key Box: DIMENSION:558X280X52mm SPECIFICATION:48keys COLOR: Light Grey MEAS:580X400X310mm Weight: 3Kg	1	No
1	Noticeboard (sample model)		Notice Board Dimension : 2000 mm(W) X 1200 mm(H) - SURFACE – self-healing cork surface, made of high-quality natural cork layered with a fibreboard - FRAME – anodized grey aluminium frame with dark grey plastic corners - ASSEMBLY – simple assembly with mounting materials included - USE – ideal for attaching notes, documents, pictures, etc. with push pins	1	No
2	cabinet (sample model)		FULL HEIGHT SWING DOOR CUPBOARD WITH 6 LAYERS OF SHELVES CAPABLE OF STORING diferent items	2	Nos.
3	Whiteboard with stand (2440 X 1220mm)s (sample model)		Wall – mounted Magnetic Whiteboard (2440mm X 1220 mm) Features Magnetic Whiteboard: Attach messages, reminders, to-do lists, photos, etc. Durable & Stain-Resistant Surface: Easy write on and wipe off without stain. Aluminium Frame: Durable, rust-proof and lightweight. Rounded PP Caps: Ensures safety and prevent bumps and scratches. Handy Pen Tray: Perfect for storing marker and keep them close at hand.	4	Nos.

APPENDIX - D

REVISED SECTION-6 FOR PACKAGE 0146

SERIAL NO	ITEM	PICTURE	SPECIFICATION	QUANTITY	UNIT
4	Computer Table (sample model)		12th Gen Intel® Core™ i3-12100 (12 MB cache, 4 cores, 8 threads, 3.30 GHz to 4.30 GHz Turbo)	2	No
5	Printer		4-in-1 multifunction colour laser printer - A4, A3 - Copy, print, scan resolution: 600 x 600 dpi or higher - Memory: 128MB minimum or better - Parallel or USB connectivity - Compatible with Windows - Duplex printing - Wi Fi Enable Print technology laser Duplex scanning, Glass platen Ethernet connectivity Multipurpose tray A3 & A4	1	No
6	Computer Table (sample model)		Computer Table with cable management Laminate table top Colour – black Finish- powder coated Frame metal - Steel Dimensión: 1800 mm(W) X800 mm (D) X 750 mm (H) Power supply provision must be there with Modesty panel	1	No
7	Trainer Chair (sample model)		Fabric Office chair with arm rest ; adjustable height.	4	Nos
8	Trainer Table (sample model)		Laminate table top 20 mm plywood top, full weld steel legs and rails, Plywood modesty board, 20 mm plywood top, full weld steel legs and rails, Plywood modesty board, Size (in mm) - 1500 (W) * 650 (D) * 700 (H), Size (in mm) - 1500 (W) * 650 (D) * 700 (H), Supply, fabricate and Deliver to site, C/W 3 drawer pedestal with locking system, C/W pop up box mounted in the middle with following specifications, C/W pop up box mounted in the middle with following specifications, Hydraulic Pop Up Box/Cable Cubby with Switch 2 Universal Power Socket + 2 RJ-45 (CAT-6) + 1 VGA + 1 USB (DATA) + 1 HDMI (4K) + 1 3.5 MM AUX Port Cable Manager (MX 7002)	4	Nos

APPENDIX E

(REVISED SECTION-6 FOR PKG 0147)

SL. NO	ITEM	SPECIFICATION	QUANTITY	UNIT
1	PC Workstation	21.5 inch Monitor with HDMI/DP with FHD 60Hz or more Processor 12th Gen Intel® Core™ i7 Operating System Windows 11 Pro, English Video Card Intel® UHD Graphics/iris Memory 16 GB DDR4, 3200 MT/s Storage 512 GB, M.2, PCIe NVMe, SSD Support Services-3Y Basic Onsite Service Keyboard- Multimedia Wired Keyboard Mouse- Optical Mouse Ports 10 USB Ports Wireless Wi-Fi 6 AC/AX Bluetooth® wireless card Power Efficiency 90% Power Efficiency Certification: Epeat(India), ROHS, Energy Star, Windows, ISO9001, ISO14001, ISO 27001	45	Set
2	4-in-1 multifunction Colour laser Printer- A4,A3	4-in-1 multifunction colour laser printer - A4, A3 - Copy, print, scan resolution: 600 x 600 dpi or higher - Memory: 128MB minimum or better - Parallel or USB connectivity - Compatible with Windows - Duplex printing with ADF Scanning -Wifi enabled Ethernet connectivity Print technology: Laser Certifications: Energy Star	2	Unit



APPENDIX E

(REVISED SECTION-6 FOR PKG 0147)

SL. NO	ITEM	SPECIFICATION	QUANTITY	UNIT
3	Multimedia Projector	Smart Interactive LCD Projector / Digital Teaching Device with •CPU - Intel Core i7 •RAM (GB) - 8 •SSD – 512 GB •OS Compatibility - Windows 10 Professional •VGA Port - Yes •HDMI Port - YES •No. of USB 2.0 Ports (Nos) - 4 •No. of USB 3.0 Ports (Nos) - 2 •Keyboard & Mouse - YES •Central Controller - Available •Board Aspect Ratio - 16 : 9 •Touch interface - pen driven •Touch Technology - Infrared Smart Interactive LCD Projector / Digital Teaching Device with •CPU - Intel Core i7 •RAM (GB) - 8 •SSD – 512 GB •OS Compatibility - Windows 10 Professional •VGA Port - Yes •HDMI Port - YES •No. of USB 2.0 Ports (Nos) - 4 •No. of USB 3.0 Ports (Nos) - 2 •Keyboard & Mouse - YES •Central Controller - Available •Board Aspect Ratio - 16 : 9 •Touch interface - pen driven •Touch Technology - Infrared •Ability to integrate cameras in future •In built Speakers - Yes •Bluetooth connectivity - Yes •Wi-Fi connectivity - Yes •LAN Connectivity - Yes	3	Unit



APPENDIX E

(REVISED SECTION-6 FOR PKG 0147)

SL. NO	ITEM	SPECIFICATION	QUANTITY	UNIT
4	Complete Sound System with amplifier with console	A complete sound system should include main components :- an amplifier, Mixer console – allows you to control the different levels that are received from input devices and sent to the speakers - 4 output to the speakers and 6 inputs for wired microphones and wireless microphones and from computer; Speakers,400 W Power output detachable 8 -channel mixer ,2 two way bass reflex speakers Microphones – 1 wireless and 1 wireless clip on ,bluetooth audio streaming	1	Set
5	Bag Compartment Shelf	<p>LxWXH = 300mmX450mmx300mm per compartment for a bag. 4 layers and 5 columns per shelf Storage construction in laminated ply wood with PVC edge band. Powder coated mild steel pipe bottom frame Mounted on PVC leveller.</p> 	3	Nos
6	Display Cabinet	<p>Steel Half Height Cupboard with Sliding Glass Doors Color Option : Grey, Beige and Two Tone With Powder Coated Sliding glass doors With 1 Adjustable Shelf Loading Capacity per Shelf : 35 kg Weight of the cabinet : 27 kg Lockable and supplied with 2 Keys Includes factory installed lock</p>  <p>1915 x L915 x D457</p>	8	Nos

APPENDIX E

(REVISED SECTION-6 FOR PKG 0147)

SL. NO	ITEM	SPECIFICATION	QUANTITY	UNIT
7	Extension cords, cables	4 Sockets 6 Amp Extension Board with minimum 4 meter Cable. Reputed make. 	12	Nos
8	Key Box	Metal Key Box: DIMENSION:558X280X52mm SPECIFICATION:48keys COLOR: Light Grey MEAS:580X400X310mm Weight: 3Kg 	5	Nos
9	Notice Board	Notice Board Dimension : 2000 mm(W) X 1200 mm(H) <ul style="list-style-type: none"> • SURFACE – self-healing cork surface, made of high-quality natural cork layered with a fibreboard • FRAME – anodized grey aluminium frame with dark grey plastic corners • ASSEMBLY – simple assembly with mounting materials included • USE – ideal for attaching notes, documents, pictures, etc. with push pins 	2	Nos



APPENDIX E

(REVISED SECTION-6 FOR PKG 0147)

SL. NO	ITEM	SPECIFICATION	QUANTITY	UNIT
10	Printer table	<p>2-Tier Desktop Printer Stand with Storage Shelf & Adjustable Anti-Skid Feet, Home Office Printer Table Space Organizer for Printer, Scanner,Termite resistance strong wood material. It should accommodate a multi function printer. Approximate dimension 600mm*450mm</p> 	2	Nos
11	Projection Screen - ceiling mounted	<p>Motorised Projection Screen – ceiling-mounted with remote control Dimension: 6ft x 6ft (Minimum) · Equipped with an Economical Motor with Heat Protection System · Infrared Remote Control and Wall Switch Control (UP / STOP / DOWN) · High-Quality Matte-White Fabric - Offers clear and vivid pictures · Deluxe Streamline Metal Case - Advanced technic, Easy to Install · Smooth Coating - Octagonal Steel case \ Motorized projector screen with remote control</p>  	2	Nos



APPENDIX E

(REVISED SECTION-6 FOR PKG 0147)

SL. NO	ITEM	SPECIFICATION	QUANTITY	UNIT
12	Steel Cabinets (Half-Height) with glass door	Steel Half Height Cupboard with Sliding Glass Doors Color Option : Grey, Beige and Two Tone With Powder Coated Sliding glass doors With 1 Adjustable Shelf Loading Capacity per Shelf : 35 kg Weight of the cabinet : 27 kg Lockable and supplied with 2 Keys Includes factory installed lock  Size: H915 x L915 x D457	6	Nos
13	Steel Cabinets (Half-Height) with metal door	Surface Finish- Paint Coated/ Powder Coated Features- Rust Proof Color- White Material- Mild Steel Door Opening Typ- Sliding Size: H915 x L915 x D457 	6	Nos



APPENDIX E

(REVISED SECTION-6 FOR PKG 0147)

SL. NO	ITEM	SPECIFICATION	QUANTITY	UNIT
14	Student Chair	<p>Dimension: W 580 X D 510 X H 830 MM Similar or closer to the size. MATERIAL: MESH & WITH MESH CUSHION, 5-Prong nylon base for stability. Twin Wheel heavy-duty swivel Castor for easy mobility under load. Seat Hot pressed ply wood with steel T-Nuts for rigid fastening with PP cover. Back is moulded Bright Bar with stitched Mesh Cloth. Quality tapestry. High density Moulded PU cushion. Picture is for indicative purpose. Colour: Will be confirmed at time of purchase. (Provide catalogue)</p> 	41	Nos
15	Teacher Chair	<p>Fabric Office chair with arm rest ; adjustable height. inch Thick Foam Cushion Padded Seat for your long hour comfort .Pneumatic Hydraulic with 3 inch seat height adjustment Breathable contoured Mesh Back Fabric . Chair comes with Sturdy Metal Base for extra strength Arm-rest : Padded Arm-rest Height Suitability : 5 ft to 5.8" ft Adjustable Back Angle: 120 degrees Chair Cover Material: Fabric Mesh Dimensions: 53D x 46W x 104H Centimeters</p> 	4	Nos



APPENDIX E

(REVISED SECTION-6 FOR PKG 0147)

SL. NO	ITEM	SPECIFICATION	QUANTITY	UNIT
16	Computer table	<p>Computer Table with cable management with provision for 2 CPUs and 2 keyboard trays as shown (for Double sitting) Colour – black Finish- powder coated Frame metal - Steel Dimension: W 1800 mm X D 800 mm X H 750 mm Similar or closet to size. Power supply provision on table (2 Switch with twin gang 230V, 6/16 A socket outlet) With modesty panel(All pictures are for indicative purpose)</p> <div style="display: flex; justify-content: space-around; align-items: center;">   </div>	20	Nos



APPENDIX E

(REVISED SECTION-6 FOR PKG 0147)

SL. NO	ITEM	SPECIFICATION	QUANTITY	UNIT
17	Teacher table	<p>Specification: Laminated(Grey) 20 mm plywood top,full weld stell legs and rails,Plywood modesty board Size(in mm)- 1500 (W)*650(D)*700(H) Supply, fabricate and Deliver to site C/W 3 drawer pedestal with locking system C/W pop up box mounted in the middle with following specifications Hydraulic Pop Up Box/Cable Cubby with Switch 2 Universal Power Socket + 2 RJ-45 (CAT-6) + 1 VGA + 1 USB (DATA) + 1 HDMI (4K) +1 3.5 MM AUX Port Cable Manager(MX 7002)</p> <div style="display: flex; justify-content: space-around; align-items: center;">   </div>	4	Nos
18	Wall Mounted Clock	<p>Wall Clocks- Battery Operated Large Wall Clock with Stereoscopic Dial Backlight, Ultra-Quiet Movement Quartz for Office ,Classroom ,School Diameter-50cm</p> <div style="text-align: center;">  </div>	2	Nos

APPENDIX E

(REVISED SECTION-6 FOR PKG 0147)

SL. NO	ITEM	SPECIFICATION	QUANTITY	UNIT
19	White Board	<p>Magnetic Whiteboard (2440mm X 1220 mm – Wall mounted)</p> <ul style="list-style-type: none"> • Magnetic Whiteboard: Attach messages, reminders, to-do lists, photos, etc. • Durable & Stain-Resistant Surface: Easy write on and wipe off without stain. • Aluminium Frame: Durable, rust-proof and lightweight. • Rounded PP Caps: Ensures safety and prevent bumps and scratches. 	2	Nos
20	Pallet Jack	<p>Spring Loaded Loop Handle 27"W x 48"L Forks 3" Non Marring Load Roller Durable Powder Coat Finish Load capacity: 2500 kg Fork Length: 1150mm Fork Width: 685mm Elevation: 190mm Nylon Wheels Lowered Fork Height: 75mm</p> 	6	Nos

APPENDIX E



(REVISED SECTION-6 FOR PKG 0147)

SL. NO	ITEM	SPECIFICATION	QUANTITY	UNIT
21	Picking Trolley with side Ladder	<p>Picking trolley equipped with a fold-out ladder. Ideal for use when putting items into stock or picking them from warehouses. Fitted with 4 castor wheels (Ø125mm). Equipped with raised edges on the shelves to prevent items from rolling off.</p> <p>Load Capacity : 350Kgs. UDL</p> <p>Dimensions (mm) :</p> <p>Height :1585 min</p> <p>Width : 550 min</p> <p>Length :1460 min</p> <p>Number of shelves : 4</p> <p>Wheel diameter (mm) :125</p> <p>Wheel type : 4 Castor Wheels</p> <p>Finishing : Powder Coated</p>	1	Nos
22	Order Picking Trolley	<p>Order Picking Trolley</p> <p>Housing Material Zinc Plated Steel</p> <p>Load Capacity 150 kg</p> <p>Wheel Diameter 100 mm</p> <p>Platform Material Metal (Blue)</p> <p>Platform Size 740 x 480 mm</p> <p>Loading Surface 628 x 480 mm</p> <p>Castor Type Standard</p> <p>Castor Height 123 mm</p> <p>Floor Height 134 mm</p> <p>Overall Weight 17.5 kg</p>	2	Nos



APPENDIX E

(REVISED SECTION-6 FOR PKG 0147)

SL. NO	ITEM	SPECIFICATION	QUANTITY	UNIT
23	Electric Forklift Truck	<ul style="list-style-type: none"> • Battery-Operated Electric Counterbalance Forklift Truck • Rear wheel drive electric • Capacity 1.5 – 2.0T. • Lifting Height 3000-6000mm • AC Motor • Large forks (Length: 800 mm) • Full hydraulic power steering • Pneumatic shaped cushion tyres • 3000mm Two Stage Mast • Voltage: 36/48V • Top speed < than 16km/hr <p>Usage/Application-Warehouse Capacity-3 ton Lift Height-6m Battery operated Lifting Speed -Full Load 20 kmph" Reputed make</p> 	2	Nos
24	Electric Reach Truck	<p>"Capacity 1200 kg to 2000 kg Product Type Battery Operated Reach Truck Lift Height 3000 mm Battery Voltage 48V"</p> 	2	Nos

APPENDIX E

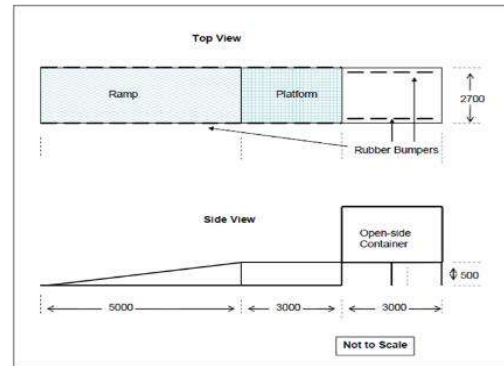

(REVISED SECTION-6 FOR PKG 0147)

SL. NO	ITEM	SPECIFICATION	QUANTITY	UNIT
25	Mock-up Steel Container & Ramp	<p>The ramp and platform must have low guard rails on both sides leading to the container (for safety precaution). Ramp material- mild steel with epoxy coated(to be certified)</p> <p>a) Ramp and platform structure consists of detachable sections covered with 6 mm thick checker plates b) Width = 2.7 m, overall length = 8.0 m and height = 0.5m. c) Each detachable section should be movable using electric forklift of 1.6 MT lifting capacity d) All the detachable components of the ramp and platform must form a single stable unit with 5 MT load capacity for forklift operations e) Safety rubber bumpers to be fitted along the lengths of the ramp and platform to prevent forklift wheels from going over the ramp and platform edges 10 Ft steel container cut-out both sides. Container diameter- 2831(L) x 2350(W)x 2390(H)- Internal 2991(L)x2438(W)x2591(H)-External</p> <p>Key note: The height of the supporting structure which container rest on and the platform can be lower than 500mm. Basically, Ramp is used for loading and unloading goods from a truck or container.</p>	1	Nos





APPENDIX E

(REVISED SECTION-6 FOR PKG 0147)

SL. NO	ITEM	SPECIFICATION	QUANTITY	UNIT
26	Warehouse Selective Racking	<p>Corrosion Protection Weight Capacity: 2000kg/layer Use: Warehouse Rack" (2 Rows ; 2 Columns; 3 Tier =24 pallet locations) Height of upright -6000mm Depth: 900 mm Beam length : 2700 mm Decking : wire mesh wheels for mobility)</p>  <p align="right">(One Row of 12 pallet locations MUST have</p>	2	Rows
27	Guard Rail	<p>Usage/Application-Industrial box pipe for way two hole each side provision to barricade in 360 degree total weight – 35-40 kg" Depth: 160 mm Material: Steel Width: 1000mm Height: 350 mm Diameter:76mm With bolts to fix.</p> 	25	Nos



APPENDIX E

(REVISED SECTION-6 FOR PKG 0147)

SL. NO	ITEM	SPECIFICATION	QUANTITY	UNIT
28	65" Interactive TV	Interactive Flat Panel Android 11.0, 4K UHD Multitouch Screen Display 4 GB RAM 32 GB ROM Display Technology-LED, Interactive white board Mounting Hardware-Power Cable, Remote, Styler Pen, Display Unit, Wall mount Kit Connector Type-Wi-Fi Audio input compatible with the item-USB, HDMI Resolution-3840 x 2680 pixel Resolution-3840x2160 Pixels 	2	Nos
29	Safety Shoes	Length-Low ankle Insole Material-PU Feature-Chemical Resistant, Heat Resistant With Lining-Yes Steel toe cap-Provided Size- 7/8/9/10/11(UK) Actual size and quantity of each size will be advised. 	55	Nos
30	Bollard	Material-Mild Steel, Shape-Cylindrical Surface -Finished (Preferably to have each bollard with Black & Yellow stripes) Height: 900mm Diameter: 90mm with a wall thickness of 2mm Base Plate: OD 200mm with a thickness of 5mm Fixing: 4 units of M12 X 80mm expansion anchor bolts (included) 	13	Nos

APPENDIX E

(REVISED SECTION-6 FOR PKG 0147)

SL. NO	ITEM	SPECIFICATION	QUANTITY	UNIT
31	Safety Helmet	ISI marked safety helmet with Ratchet type adjustment for outdoor head protection, Item Weight 300 Grams Colour-Yellow and White Quantity and colour to be advised. <div style="text-align: center;">  </div>	30	Nos
32	Safety Vest	The vest preferably breathable material in view of the hot weather. It should have multifunction pockets. <div style="text-align: center;">  </div>	30	Nos
33	Traffic Cones	PVC Construction Cones, 2 Reflective Collars Traffic Cones with Weighted Base and Hand-Held Ring Used for Traffic Control, Drive way Road Parking Dimension-28"height 13" x 13" base 6" and 4" collars Provide catalogue <div style="text-align: center;">  </div>	25	Nos

APPENDIX E

(REVISED SECTION-6 FOR PKG 0147)

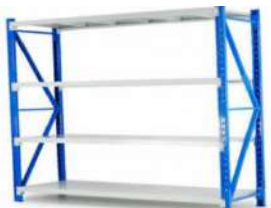

SL. NO	ITEM	SPECIFICATION	QUANTITY	UNIT
34	400-watt, portable PA system with 8-channel powered mixer, two 8" speakers	<ul style="list-style-type: none"> • 1 x 400W Wireless Rechargeable Portable Bluetooth PA System • 1 x Handheld VHF Wireless Microphone • 1 x 1/4" to Aux Audio Cable (3.5mm) and Adapter • 1 x Battery Terminal Alligator Clamp Cables • 1 x RCA Connection Cable • 1 x Power Cable • 8-channel powered mixer, two 8" speakers, 	2	Set
35	Teaching Aids (DG Charts, Atlas, Container chart)	laminated posters-(2 ft width * 3ft length) made up of synthetic material that serves as teaching aids - Dangerous Good, Hazardous Classifications; Containers sizing, Work place Safety Guidelines, Personal Protection equipment World map- (Material-vinyl, 140 cm X 100 cm, laminated) (1 Set consists of 2 Nos of each of the above items), Atlas Content will be advised.	2	Set
36	Warehouse Long Span shelves (Dim: 2500mm (H) x 500mm (D) x 1500mm)	Material- Steel Type-Adjustable shelving Racks 2500mm Length – 1500mm Depth – 500mm Finishing – Epoxy Coated Corrosion prevention Storage Capacity-500 to 800 Kgs	24	Nos



Height-

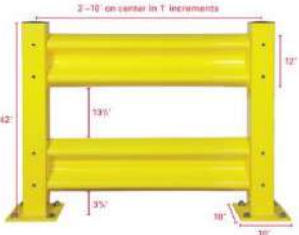

APPENDIX E

(REVISED SECTION-6 FOR PKG 0147)

SL. NO	ITEM	SPECIFICATION	QUANTITY	UNIT
37	Guard Rail(Perimeter)	<p>set – 2 pole + 2 sheet material – mild Stee Rails: 12" high x 1/8"-thick, double-ribbed rail design Posts: High Strength Steel Post, 4"x4" Tube; Steel Baseplate, 10 in. x 10 in. x 5/8 in. thick,42 inch length Color: OSHA Yellow Finish Rail length- 5ft</p> 	25	Nos
38	Carton Box (assorted)	<p>From above dimensions of a cartón; a pallet should have 24 cartons and stack height should not exceed 1600 mm.</p> 	100	Nos



APPENDIX E

(REVISED SECTION-6 FOR PKG 0147)

SL. NO	ITEM	SPECIFICATION	QUANTITY	UNIT
39	Tape holder	sealing & packing cartons, boxes etc. - 3 inch For sealing, combining, reinforcing & bundling. Versatile, use it in Office, at home or for industrial purpose etc. Highly durable for daily use, hand held dispenser 	15	Nos
40	Wooden Pallet	Wooden • Dimensions: 1200x1000mm – most commonly used across Europe and Asia 	30	Nos



APPENDIX E

(REVISED SECTION-6 FOR PKG 0147)

SL. NO	ITEM	SPECIFICATION	QUANTITY	UNIT
41	Compressed Wood Pallet	Compressed wood • Dimensions: 1200x1000mm – most commonly used across Europe and Asia 	9	Nos
42	Compressed Paper Pallet	Pallet Size 1100 x 1100 x 130mm Carry load upto 750 Kgs 	9	Nos
43	Plastic Pallet	Plastic • Dimensions: 200x1000mm – most commonly used across Europe and Asia 	20	Nos





APPENDIX E

(REVISED SECTION-6 FOR PKG 0147)

SL. NO	ITEM	SPECIFICATION	QUANTITY	UNIT
44	Metal Drum (200 L) Empty	Steel Drum ((similar like an Oil drum size) • 55 gallons (200 litres) • Dimensions: Closed Head 	16	Nos
45	Pallet Mesh	Capacity-800 KGS Dimension/Size-Dimension size-800 X 600 X 650 MM Pitch-50 X 50 mm Wire Dia-6 mm 	3	Nos
46	Electronic Counting Weighing machine	Weighing capacity -300kgs Accuracy-50g Platform material -Iron Platform size -24* 24 inch 	5	Nos



APPENDIX E

(REVISED SECTION-6 FOR PKG 0147)

SL. NO	ITEM	SPECIFICATION	QUANTITY	UNIT
47	Strapping Machine	Semi Automatic Strapping Machine, 320W Strapping Speed 1.8 sec per strap Strapping Width 6 to 15 mm 	1	Nos
48	Automatic Strapping Tool	Automatic Electric Strapping Machine <ul style="list-style-type: none"> • Suitable for Packing material PP, PET • Strap Belt width 13-16 mm • Strap Belt thickness 0.5-1.2 mm • Battery capacity : 4000 mah • Charging time 90mins  <ul style="list-style-type: none"> • Sealing mode Binding force 3200N 	1	Nos
49	Impulse Sealer	24 Inch 600 W Hand Operated Impulse Sealing Machine Body Material -Aluminium Winding material -Copper 	5	Nos
50	Strapping Hand tool	Strapping Tensioner & Sealer for 15mm Strap 	5	Nos



APPENDIX E

(REVISED SECTION-6 FOR PKG 0147)

SL. NO	ITEM	SPECIFICATION	QUANTITY	UNIT
51	Drum Gripper	<ul style="list-style-type: none"> • Width, external [mm], 710 • Depth, external [mm], 890 • Height, external [mm], 975 • Distance between fork pockets [mm], 410 • Forklift pocket W x H [mm], 140 x 55 • Overall load capacity [kg], 350 • Suitable for, 1 x 205 litres steel ribbed drum / steel • Weight [kg], 70 	1	Nos
52	Fork Extension	<p>Pallet fork Extension 60 X4.5"</p> <p>Premium grade high strength steel material</p> 	1	Nos
53	Wooden Crate	<p>Wooden Crate with pallet</p> <ul style="list-style-type: none"> • Dimensions: 48 in(L)X 40in(W)WX42(H) • 1/4" thick plywood. Outside dimensions include 5" pallet. • Meets ISPM 15 requirements 	8	Nos

APPENDIX E

(REVISED SECTION-6 FOR PKG 0147)

SL. NO	ITEM	SPECIFICATION	QUANTITY	UNIT
54	Plastic Drum	Plastic drum heavy duty material (similar like an Oil drum size) <ul style="list-style-type: none"> • 55 gallons (200 litres) • Open head 	12	Nos
55	Plastic Chain	8mm * 10 mtr Heavy-Duty Plastic chain 	50	Nos
56	Labelling Printer	High-resolution printing (up to 300 x 600 dpi) Convenient, drop-in rolls. No ink or toner needed Print labels in both red or black text Print speed- 5.8"/sec. (148 mm/sec.) 	1	Nos



APPENDIX E

(REVISED SECTION-6 FOR PKG 0147)

SL. NO	ITEM	SPECIFICATION	QUANTITY	UNIT
57	RFID / Bar code reader	<p>Connectivity Technology-Bluetooth Power Source-Battery Powered Hardware Platform-Linux, Windows, Mac Operating System-Win,linux, ios Compatible Device-LAPTOP/COMPUTER/ALL IN ONE Included Component -WIRELESS DONGLE, SCANNER, USB CABLE Handheld 2D Barcode Scanner with Digital Display and Voice Alert Technology, QR Code Scanner for Shops, Super Market, Logistics, Library, Malls.</p> 	8	Nos
58	Plastic Tote storage box (Dim: 400mm(L)X 500mm(D)X220mm(H)	<p>Plastic Tote storage box (Dim: 400mm(L)X 500mm(D)X220mm(H)</p> 	72	Nos
59	Plastics Multi-purpose Bin (Dim:150mm(L)X230mm(D)X125mm(H)	<p>Plastics Multi-purpose Bin Dim:150mm(L)X230mm(D)X125mm(H)</p> 	480	Nos

APPENDIX E

(REVISED SECTION-6 FOR PKG 0147)

SL. NO	ITEM	SPECIFICATION	QUANTITY	UNIT
60	2-door full-height steel cabinet with cross bar & lock	<p>Full height swing door cupboard h1829*w914*d457*d c/w lock bar The cabinet is manufactured with 0.6 mm thick sheet steel. The cabinet is epoxy powder coated for more durability. Comes with Solid Steel 38 mm wide x 6 mm thick Security / locking bar along with heavy duty 2 mm thick Fully Welded Brackets.</p> 	5	Nos
61	Industrial Wet & Dry Vacuum cleaner	<p>Adjustable floor tools for carpet and hard floors. Hard floor nozzle developed for in-depth cleaning of floors with crevices and gaps like tiles and floorboards.Suitable for gentle cleaning of sensitive floors like Parquet. Industrial Vacuum Cleaner 35Litre 1500W with Blower Includes High Suction Power Stainless Steel Length of the Cable : 5 Mtr</p>	1	Nos
62	Round convex mirror	<p>Mirror Size: 16 Inch with Adjustable Wall and Pole Bracket, Type of Product: Convex Mirror For “blind corners” in Logistics Training Centre especially at the entrances/exits With metal stand of 6ft</p> 	4	Set



APPENDIX E

(REVISED SECTION-6 FOR PKG 0147)

SL. NO	ITEM	SPECIFICATION	QUANTITY	UNIT
63	Fire extinguisher	Dry Chemical Powder Cartridge Type(NFPA/IS CERTIFIED) Capacity: 9 Kg. 	12	Nos
64	CCTV (5 Units) with HD recorder	High-resolution IP cameras with IR capability for day and night surveillance. Strategically placed cameras covering entry points and critical areas. Network Video Recorder (NVR) with remote access and 30-day storage. Power backup with UPS and PoE switches. Compliance with Indian regulations and data protection laws. Remote monitoring via secure connections, maintenance schedule, and signage for deterrence. Camera: 4 MP IR Range: Upto 30m	2	Set



APPENDIX E

(REVISED SECTION-6 FOR PKG 0147)

SL. NO	ITEM	SPECIFICATION	QUANTITY	UNIT
65	Low height metal cabinet	<p>Low Height Sliding Steel Cupboard with 1 adjustable shelf size : 901mm x 445mm x 940mm</p> 	4	Set
66	First Aid Box	<p>Individually wrapped sterile adhesive Dressing x20 bandage 5cm x 1 10cm x1</p> <p>Handicrepe Handicrepe bandage Absorbent gauze 10'S x 5</p> <p>hypo Traingular banda Scissors x1 Safety Pin 10's x1 Disposable Glove Pair Eye shield x2 Eyepad x 2 Disposable CPR KIT x 1 Torch light x1</p>  <p>Water for injection 5x20mlx1</p>	2	Set



APPENDIX E

(REVISED SECTION-6 FOR PKG 0147)

SL. NO	ITEM	SPECIFICATION	QUANTITY	UNIT
67	Metal shoe cabinet	Full height swing door metal cupboard with 6 layers of shelves capable of storing 21 pairs of shoes Approx 91cmW x 46cmD x 180cmH Durable metal construction with reinforced joints for stability Scratch-resistant finish for long-lasting appearance Secure locking mechanism	2	Nos
				
68	Road safety signage	Size- 24 inch * 36 inch 4 different Posters vinyl posters with snap frames for mounting Full colour printing. Content to be advised.	4	Nos
				
69	Water dispenser (hot & cold water)	Product Description: <ul style="list-style-type: none"> •Easter cooling •Eess power consumption •Eco friendly refrigerant •Stainless steel body Cooling Capacity: 40 LPH	2	Nos
				



APPENDIX E

(REVISED SECTION-6 FOR PKG 0147)

SL. NO	ITEM	SPECIFICATION	QUANTITY	UNIT
70	Mobile work station (for instructors)	<p>Tool adjustable height Two-level design enables comfortable, ergonomic placement of keyboard, mouse, and monitors Includes a set of smooth-rolling, 3" locking casters; also features a storage shelf perfect for a printer, CPU, books, and more Overall minimum dimensions are 24" W x 28.8" D x 34.1" to 46.1" H</p> 	1	Nos
71	Pick and Pack Table	<p>The table top preferable hard plastic (PU or PP) table top and foldable . This is use for their practices to pick & pack items from shelvings. Table top may be plastic or HDPE. Dimension-1500mm X640 mmX750 mm</p> 	22	Nos



APPENDIX E

(REVISED SECTION-6 FOR PKG 0147)

SL. NO	ITEM	SPECIFICATION	QUANTITY	UNIT
72	Stool for students	Frame- Steel, Epoxy/polyester powder coating 24" fixed height. Seat: 13" diameter, 5/8" thick hard-plastic. Must be stackable 	40	Nos
73	Wooden Long Bench	Material can be wooden . Each bench should be able to sit minimum 5 person Dimension-6.25 f 1ft 6 inch (H)x1 ft 3 inch(D) 	4	Nos
74	AV equipment rack	Material-Stainless Steel No. of Shelves-3 Shelves Finish Type-Polished Enclosed Dimension-17U 600W/600D 	2	Unit



APPENDIX E

(REVISED SECTION-6 FOR PKG 0147)

SL. NO	ITEM	SPECIFICATION	QUANTITY	UNIT
75	Key Box	Metal Key Box: DIMENSION: Estimate -358mmX220mmX52mm SPECIFICATION: 20 keys COLOR: Light Grey Weight: 1.5Kg 	2	Nos
76	Projection Screen – Ceiling/wall mounted	Manual Projection Screen auto lock Size: 8' x 14' 	2	No

APPENDIX E

(REVISED SECTION-6 FOR PKG 0147)

SL. NO	ITEM	SPECIFICATION	QUANTITY	UNIT
77	Student chair	<p>Dimension: W 580 X D 510 X H 830 MM Similar or closer to the size. MATERIAL: MESH & WITH MESH CUSHION, 5-Prong nylon base for stability. Twin Wheel heavy-duty swivel Castor for easy mobility under load. Seat Hot pressed ply wood with steel T-Nuts for rigid fastening with PP cover. Back is moulded Bright Bar with stitched Mesh Cloth. Quality tapestry. High density Moulded PU cushion. Colour: Will be confirmed at time of purchase. (Provide catalogue) Foldable writing shelve/board: 1 cm thick ply Wood, anti Termite,, wáter proof, stain proof, anti dust, strong material</p> 	41	Nos
78	Whiteboard (2440 X 1220mm)	<p>Mobile Magnetic Whiteboard (2440mm X 1220 mm) with Rolling Wheel.</p> 	1	No

Appendix F

Revised Section 6 for package 0148

S/N	Key Items	Specifications	Quantity	UOM
01	55-inch Digital Signage Display	 <p>PANEL</p> <ul style="list-style-type: none"> - Screen Size: 55" - Panel Technology: IPS - Backlight Type: Direct - Aspect Ratio: 16:9 - Native Resolution: 3840 x 2160 (UHD) - Refresh Rate: 60Hz - Brightness: 300 nit (Typ.) - Contrast Ratio: 1,300:1 - Viewing Angle (H x V): 178 x 178 - Color Depth: 10-bit(D), 1.07 Billion colors - Response Time: 8ms (G to G) - Surface Treatment (Haze): 3% - Operation Hours (Hours / Days): 16 / 7 - Portrait / Landscape: Yes / Yes <p>CONNECTIVITY</p> <ul style="list-style-type: none"> - Input: HDMI (3, HDCP 2.2 / 1.4), USB 2.0 Type A (2) - Output: Audio - External Control: RS232C In / Out (4 Pin Phone Jack), RJ45 (LAN) In <p>MECHANICAL SPECIFICATION</p> <ul style="list-style-type: none"> - Bezel Color: Ashed Blue - Bezel Width: <ul style="list-style-type: none"> - Off : 6.9/6.9/6.9/18.4 mm - On : 12.8/12.8/12.8/19.9 mm - Weight (Head): 14.0 Kg - Packed Weight: 18.8 Kg - Monitor Dimension (W x H x D): 1,235 x 715 x 57.5 mm - Carton Dimensions (W x H x D) (Box outer size): 1,360 x 810 x 162 - VESA™ Standard Mount 	4	SET

Appendix F

Revised Section 6 for package 0148

S/N	Key Items	Specifications	Quantity	UOM
		<p>Interface: 300 x 300</p> <p>ENVIRONMENT CONDITIONS</p> <ul style="list-style-type: none"> - Operation Temperature: 0 °C to 40 °C (Portrait Scene: 0 °C to 35 °C) - Operation Humidity: 10% to 80% <p>POWER</p> <ul style="list-style-type: none"> - Power Supply: AC 100-240V~, 50/60Hz - Power Type: Built-In Power <p>POWER CONSUMPTION</p> <ul style="list-style-type: none"> - Typical: 105 W - Max: 160 W - BTU (British Thermal Unit): 358 BTU/Hr (Typ.), 512 BTU/Hr (Max.) - Smart Energy Saving(70%): 73.5 W - DPM: 0.5 W - Power off: 0.5 W <p>SOUND</p> <ul style="list-style-type: none"> - Speaker: Yes <p>CERTIFICATION</p> <ul style="list-style-type: none"> - Safety: CB - EMC: FCC Class "A" / CE - ErP / Energy Star: Yes (Old ErP for Jordan) / No <p>SOFTWARE COMPATIBILITY</p> <ul style="list-style-type: none"> - SuperSign CMS: Yes - SuperSign WB: Yes - SuperSign Media Editor: Yes - SuperSign Control / Control+: Yes - LG Connected Care: Yes - Promota: Yes <p>ACCESSORY</p> <ul style="list-style-type: none"> - Basic: Remote Controller (include battery 2ea), Power Cord, Regulation Book, Phone to D-Sub9 Gender, Cable Holder 		
02	Interactive Panel-85-inch Displays or better		4	SET

Appendix F

Revised Section 6 for package 0148

S/N	Key Items	Specifications	Quantity	UOM
		 <p>Display</p> <ul style="list-style-type: none"> - Diagonal Size: 75" - Panel Type: VA - Resolution: 3,840 x 2,160 - Pixel Pitch (HxV): 0.2451x0.2451(mm) - Brightness (Typical): 350 (220 with glass) - Contrast Ratio: 4000:1 (without glass) - Viewing Angle (H/V): 178/178 - Response Time: 8ms - Colour Gamut: 72% - Glass Haze: 2% (without glass) - H-Scanning Frequency: 30~81kHz - Maximum Pixel Frequency: 594Mhz - V-Scanning Frequency: 48~75Hz - Dynamic Contrast Ratio: N/A <p>Connectivity</p> <ul style="list-style-type: none"> - HDMI In: 2 - DP In: 1 - DVI In: N/A - Tuner In: N/A - USB: 2 (Main/Tray), 2.0/3.0 External (Tray) - IR In: N/A - HDBaseT In: N/A - Audio In: N/A - Audio Out: Stereo Mini Jack - Video Out: Yes - Power Out: N/A - RS232 In: Yes - RS232 Out: N/A - RJ45 In: Yes - RJ45 Out: N/A - WiFi: Yes - 3G Dongle: N/A 		

Appendix F

Revised Section 6 for package 0148

S/N	Key Items	Specifications	Quantity	UOM
		<ul style="list-style-type: none"> - Bluetooth®: Yes Power - Power Supply: AC100-240V 50/60Hz - Power Consumption (Off Mode): N/A - Power Consumption (On Mode): 275W - Power Consumption (Sleep Mode): 0.5W 		
03	Apple Vision Pro	 <p>Capacity</p> <ul style="list-style-type: none"> - 1TB <p>Display</p> <ul style="list-style-type: none"> - 23 million pixels - 3D display system - Micro-OLED - 7.5-micron pixel pitch - 92% DCI-P3 - Supported refresh rates: 90Hz, 96Hz, 100Hz - Supports playback multiples of 24fps and 30fps for judder-free video - Video Mirroring: Up to 720p AirPlay for mirroring your view in Apple Vision Pro to any AirPlay-enabled device, including iPhone, iPad, Mac, Apple TV (2nd generation or later), or AirPlay-enabled smart TV <p>Chips</p> <ul style="list-style-type: none"> - Graphic image of the M2 chip - 8-core CPU with 4 performance cores and 4 efficiency cores - 10-core GPU - 16-core Neural Engine - 16GB unified memory - Graphic image of the R1 chip - 12-millisecond photon-to-photon 	5	SET

Appendix F

Revised Section 6 for package 0148

S/N	Key Items	Specifications	Quantity	UOM
		<p>latency</p> <ul style="list-style-type: none"> - 256GB/s memory bandwidth <p>Camera</p> <ul style="list-style-type: none"> - Stereoscopic 3D main camera system - Spatial photo and video capture - 18 mm, <i>f</i>/2.00 aperture - 6.5 stereo megapixels <p>Sensors</p> <ul style="list-style-type: none"> - Two high-resolution main cameras - Six world-facing tracking cameras - Four eye-tracking cameras - TrueDepth camera - LiDAR Scanner - Four inertial measurement units (IMUs) - Flicker sensor - Ambient light sensor - Optic ID: Iris-based biometric authentication - Optic ID data is encrypted and accessible only to the Secure Enclave processor - Secures personal data within apps - Make purchases from the iTunes Store and App Store <p>Audio Technology</p> <ul style="list-style-type: none"> - Spatial Audio with dynamic head tracking - Personalized Spatial Audio and audio ray tracing - Six-mic array with directional beamforming - Supports H2-to-H2 ultra-low-latency connection to AirPods Pro (2nd generation) with MagSafe Charging Case (USB-C) <p>Audio Playback</p> <ul style="list-style-type: none"> - Supported formats include AAC, MP3, Apple Lossless, FLAC, Dolby Digital, Dolby Digital Plus, and Dolby Atmos <p>Video Playback</p> <ul style="list-style-type: none"> - Supported formats include HEVC, 		

Appendix F

Revised Section 6 for package 0148

S/N	Key Items	Specifications	Quantity	UOM
		<p>MV-HEVC, H.264, HDR with Dolby Vision, HDR10, and HLG</p> <p>Battery</p> <ul style="list-style-type: none"> - Up to 2 hours of general use - Video watching up to 2.5 hours - Apple Vision Pro can be used while charging the battery <p>Connectivity and Wireless</p> <ul style="list-style-type: none"> - Wi-Fi 6 (802.11ax) - Bluetooth 5.3 <p>Operating System</p> <ul style="list-style-type: none"> - visionOS <p>Input</p> <ul style="list-style-type: none"> - Hands - Eyes - Voice - Supported Input Accessories: Keyboards, Trackpads, Game controllers <p>Interpupillary Distance (IPD)</p> <ul style="list-style-type: none"> - 51–75 mm <p>Device Weight</p> <ul style="list-style-type: none"> - 21.2–22.9 ounces (600–650 g) - Weight varies depending on Light Seal and headband configuration. Separate battery weighs 353 g. <p>Accessibility</p> <ul style="list-style-type: none"> - Accessibility features help people with disabilities get the most out of their new Apple Vision Pro. With built-in support for vision, hearing, mobility, and learning, you can create and do amazing things. <p>Features Include</p> <ul style="list-style-type: none"> - VoiceOver - Zoom - Color Filters - Hearing Device Support - Closed Captioning - Voice Control - Switch Control 		

Appendix F

Revised Section 6 for package 0148

S/N	Key Items	Specifications	Quantity	UOM
		<ul style="list-style-type: none"> - Dwell Control - Pointer Control - Support for Made for iPhone bi-directional hearing aids - Support for Made for iPhone switch controllers 		
S04	Insta360 ONE RS 1-Inch 360	<div style="text-align: center;">  </div> <p>Specs</p> <ul style="list-style-type: none"> -Aperture <ul style="list-style-type: none"> - F2.2 -35mm Equivalent Focal Length <ul style="list-style-type: none"> - 6.52mm -Photo Resolution <ul style="list-style-type: none"> - 6528x3264 (2:1) -Video Resolution <ul style="list-style-type: none"> - 5888x2944 @30fps - 6144x3072 @25/24fps - 3840x1920 @30/25/24fps - 3040x1520 @50fps -Photo Format <ul style="list-style-type: none"> - insp - RAW (dng) (RAW files require software on PC/Mac to export.) -Video Format <ul style="list-style-type: none"> - insv (can be exported via App or Studio) -Photo Modes <ul style="list-style-type: none"> - Standard, HDR, Interval, Starlapse, Burst, PureShot -Video Modes 	10	SET

Appendix F

Revised Section 6 for package 0148

S/N	Key Items	Specifications	Quantity	UOM
		<ul style="list-style-type: none"> - Standard Video, Timelapse, TimeShift, Loop Recording -Color Profiles <ul style="list-style-type: none"> - Standard, Vivid, LOG -Weight <ul style="list-style-type: none"> - 239g -Dimensions (W x H x D) <ul style="list-style-type: none"> - 53.2x129.3x49.5mm -Run Time <ul style="list-style-type: none"> - 62 minutes (*Tested in lab environment under 6K@30fps mode) -Compatible Devices <ul style="list-style-type: none"> - iOS Devices: <ul style="list-style-type: none"> - Compatible with iOS mobile devices with chips A11 or above and iOS version 11.0 or above, including iPhone SE 2, iPhone 8, iPhone 8 Plus, iPhone XR, iPhone XS, iPhone XS Max, iPhone X, iPhone 11, iPhone 11 Pro, iPhone 11 Pro Max, iPhone 12, iPhone 12 Pro, iPhone 12 Pro Max, iPhone 12 mini, iPhone 13, iPhone 13 Pro, iPhone 13 Pro Max, iPhone 13 mini, iPad Air (2020), iPad Pro, and newer iPad models. - Android Devices: <ul style="list-style-type: none"> - Compatible with Android mobile devices that meet the following capabilities, including: <ul style="list-style-type: none"> - Android devices with Kirin 980 and above chips, including Huawei Mate 20, P30, or newer models. - Android devices with Snapdragon 845 and above chips, including Samsung Galaxy S9, Xiaomi Mi 8, or newer models. - Android devices with Exynos 9810 and above chips, including Samsung Galaxy S9, S9+, Note9, and newer models. - Android devices with Tensor chips, including Google Pixel 6. - Note: <ul style="list-style-type: none"> - Devices that do not meet the above requirements may still be able to use the app and control the camera, however, performance may be sub-optimal. 		

Appendix F

Revised Section 6 for package 0148

S/N	Key Items	Specifications	Quantity	UOM
		<ul style="list-style-type: none"> - Phones equipped with Qualcomm SDM765 5G chips have poor hardware decoding capabilities and are not supported. - App installation on the mobile phone requires 64-bit systems. Phones with 32-bit systems are not supported. - The Snap Wizard feature is only compatible with iPhone 8 and above models (A11 or above chips); iPads with M1 chips; Android devices with Kirin 990 and above chips (e.g. Huawei Mate 30 and above), Snapdragon 855 and above chips (e.g. Google Pixel 4/Xiaomi Mi 9 and above), and Exynos 990 and above chips (e.g. Samsung Galaxy S20 and above). -Max Video Bitrate <ul style="list-style-type: none"> - 120Mbps -Gyroscope <ul style="list-style-type: none"> - 6-axis Gyroscope -Live Streaming <ul style="list-style-type: none"> - 360 Live, Reframe Live (streamer sets a fixed perspective) -Exposure Value <ul style="list-style-type: none"> - ±4EV -ISO Range <ul style="list-style-type: none"> - Photo: 100-3200 - Video: 100-3200 -Shutter Speed <ul style="list-style-type: none"> - Photo: 1/8000 - 120s - Video: 1/8000 - to the limit of frames per second -White Balance <ul style="list-style-type: none"> - 2000K-10000K -Audio Modes <ul style="list-style-type: none"> - Wind Reduction - Stereo -Audio Format <ul style="list-style-type: none"> - 48 kHz, AAC -Bluetooth <ul style="list-style-type: none"> - BLE5.0 -Wi-Fi <ul style="list-style-type: none"> - 5 GHz, 802.11ac (Standard range of approximately 20 meters, max transmission speed of 20MB/s) -USB <ul style="list-style-type: none"> - Type-C 		

Appendix F

Revised Section 6 for package 0148

S/N	Key Items	Specifications	Quantity	UOM
		<ul style="list-style-type: none"> - *Note: This camera only supports wired connection to Android devices (via Micro-USB or Type-C). It does not support wired connection to iOS devices. Full wireless support is available for both iOS and Android. -MicroSD Card <ul style="list-style-type: none"> - exFAT formatted microSD cards with the UHS-I bus interface and Video Speed Class V30 rating (exactly this class, neither higher or lower) with a max storage of 1TB are recommended. -Battery Capacity <ul style="list-style-type: none"> - 1350mAh -Charging Method <ul style="list-style-type: none"> - Type-C USB -Charging Time <ul style="list-style-type: none"> - 90 minutes (powered off) -Operating Temperature <ul style="list-style-type: none"> - -4°F to 104°F (-20°C to 40°C) 		
05	Oculus Meta Quest 3 – 512GB	<div style="text-align: center;">  </div> <p>Power</p> <ul style="list-style-type: none"> -Advanced hardware stack and the first headset with the Snapdragon XR2 Gen 2, delivering double the GPU processing power for faster load times and more seamless gameplay compared to Meta Quest 2. This brings enough power to support heavy applications like fast-action gaming, seamless full-color, high-resolution passthrough and so much more. 	10	SETS

Appendix F

Revised Section 6 for package 0148

S/N	Key Items	Specifications	Quantity	UOM
		<p>Storage -128GB and 512GB options. Enables continued exploration of the vast library of titles.</p> <p>Mixed reality -2 RGB cameras with 18 PPD, for 10X the resolution of Quest 2 and 3X the resolution of Quest Pro in passthrough. Delivers full-color, high-fidelity views of your surroundings while you see virtual objects appear in your physical space. Accurate depth projection and room mapping give you the freedom to move throughout your space and interact with virtual characters or objects in the room around you.</p> <p>Audio -Integrated stereo speakers with 3D spatial audio place you in your space with 40% louder audio range, bass range and optimal L/R matching capabilities. 3.5mm audio jack for headphones and sound output to external audio devices.</p> <p>DRAM -8GB. 33% more memory compared with Meta Quest 2, giving you more support to play your favorite apps with optimal performance.</p> <p>Ergonomics -Strap design: Soft adjustable strap accommodates a variety of head shapes and hairstyles; Hard strap is available and sold separately. -Depth adjustment: Easily adjust the facial interface closer or farther from your face to improve comfort and field of view. -Headset weight: 515 grams. Pancake optics create a 40% slimmer optic profile* for more comfortable wear. *As compared to Quest 2 excluding</p>		

Appendix F

Revised Section 6 for package 0148

S/N	Key Items	Specifications	Quantity	UOM
		<p>the facial interface.</p> <p>Display and optics technology -Display resolution: 2064x2208 pixels per eye enhances resolution by nearly 30% compared to Meta Quest 2 for next-level clarity and lifelike graphics. 4K+ Infinite Display with 25PPD and 1218 PPI brings the best resolution across the entire Quest line of devices. -Refresh rate: 72Hz, 80Hz, 90Hz, 120Hz. -Field of view: 110 degrees horizontal and 96 degrees vertical. This extends your peripheral vision to let you see more of virtual worlds, all at once, for the most immersive experiences yet. -Optics: Pancake lens provides a slimmer optic profile* without compromising the depth of your visual immersion. Increased sharpness by 25% in center FOV (~70% sharper in periphery), with significantly less stray or scattered light artifacts. *As compared to Quest 2 excluding the facial interface. -Lens adjustment: Accommodated IPD range: 53-75 mm, with mechanical lens spacing adjustment wheel for smooth adjustment and better visual clarity. Our innovative optical design allows for an eye box that covers a wider range of interpupillary distances than ever before.</p> <p>Meta Quest Touch Plus Controllers -Comfort: Play comfortably with a streamlined, ring-free design. Experience more natural movement and precise input as if they're a natural extension of your hands. -Haptics: TruTouch variable haptics provide tactile feedback, enabling a more holistic range of in-experience sensations so you can touch, move and react realistically within virtual</p>		

Appendix F

Revised Section 6 for package 0148

S/N	Key Items	Specifications	Quantity	UOM
		<p>environments.</p> <p>Experience -Mixed reality passthrough: 2 RGB Color cameras and depth projector for improved depth and resolution. -Direct touch hand tracking: Advanced hybrid computer vision and machine learning sensors follow your gestures, with 4 IR cameras and 2 RGB cameras to enable controller-free navigation and more intuitive control. Simply move your hands to tap, scroll, navigate and play.</p> <p>Content library -500+ titles bring a vast library of experiences. There's something for everyone to discover in more immersive ways, thanks to mixed reality and better performance enabling faster load times, seamless play and ultra-realistic graphics.</p> <p>Backwards compatibility -Full access to the entire catalog of Meta Quest apps, games and experiences. Keep playing your favorite titles, with game updates to optimize viewing and performance.</p> <p>PC support -Supported with Meta Quest Link Cable and Air Link to connect your headset to the power of your PC to unlock yet another level of gameplay (available separately).</p> <p>Charging -Battery life: Up to 2.2 hours of usage on average for gaming, social, productivity, and media. Battery life is dependent on various factors such as device settings, usage, age of battery, Bluetooth usage, and wireless conditions. -Charge time: Approximately 2.3 hours with the included 18W power</p>		

Appendix F

Revised Section 6 for package 0148

S/N	Key Items	Specifications	Quantity	UOM
		<p>adapter (headset only). -Easy charging: Built-in USB-C port for charging and connectivity. Contact pads on bottom of device simplify charging, when combined with the external dock accessory (available separately).</p> <p>Wi-Fi -Wi-Fi 6E certified (region permitting).</p> <p>Privacy -External LED: Signal notifies bystanders that the external cameras are in use. -Data protection: Advanced encryption plus customized settings include data sharing opt-in/opt-out, electronic mic/camera disconnect and password/PIN protection to let multiple users explore safely.</p>		
06	Laptop 14"	<div data-bbox="576 1137 1050 1487" data-label="Image"> </div> <p>Processor -Intel® Core™ 7 processor 150U (12MB cache, 10 cores, 12 threads, up to 5.4 GHz)</p> <p>Operating System -(Dell Technologies recommends Windows 11 Pro for business) -Windows 11 Home, English</p> <p>Video Card -Intel® Graphics</p> <p>Display -14.0-inch 16:10 FHD+ (1920 x 1200) Anti-Glare Non-Touch</p>	10	SET

Appendix F

Revised Section 6 for package 0148

S/N	Key Items	Specifications	Quantity	UOM
		<p>250nits WVA Display with ComfortView Support</p> <p>Memory -16GB, 2x8GB, DDR5, 5200 MT/s</p> <p>Storage -1 TB, M.2, PCIe NVMe, SSD</p> <p>Colour -Ice Blue Metal Cover</p> <p>Microsoft Office -None</p> <p>Security Software -McAfee+ Premium 1-year</p> <p>Support Services -2Y Premium Support with Hardware and Software 1-2 Biz Day Onsite after remote diagnosis</p> <p>Accidental Damage Protection -NONE</p> <p>Keyboard -Ice Blue English International AI Backlit Keyboard</p> <p>Ports -For computers shipped with 120U/150U processors -2 USB 3.2 Gen 1 (5 Gbps) ports -1 USB 3.2 Gen 2 (10 Gbps) Type-C® with Power Delivery and DisplayPort™ -1 headset (headphone and microphone combo) port -1 HDMI 1.4 port -1 power-adaptor port</p> <p>Note: HDMI output supports up to 1920x1080 @ 60Hz, 24bpp. No 4K/2K output supported.</p> <p>Slots -1 SD-card slot -1 Wedge-shaped lock slot</p>		

Appendix F

Revised Section 6 for package 0148

S/N	Key Items	Specifications	Quantity	UOM
		<p>Dimensions & Weight</p> <ul style="list-style-type: none"> -Aluminium -Height (Front): 15.86 mm (0.62 in.) -Height (Rear): 17.31 mm (0.68 in.) -Width: 314.00 mm (12.36 in.) -Depth: 226.15 mm (8.90 in.) -Weight (Minimum): 1.56 kg (3.44 lb) -Weight (Maximum): 1.65 kg (3.64 lb) <p>Camera</p> <ul style="list-style-type: none"> -1080p at 30 fps widescreen FHD-RGB camera, Dual-array microphones <p>Audio and Speakers</p> <ul style="list-style-type: none"> -Stereo speakers with Waves MaxxAudio® Pro and Dolby Atmos Core, 2W x 2 = 4W total <p>Chassis</p> <ul style="list-style-type: none"> -Exterior Chassis Materials: Aluminium exterior shell -Color options: Ice Blue -Touchpad: Ice Blue: Precision touchpad <p>Wireless</p> <ul style="list-style-type: none"> -Realtek Wi-Fi 6 RTL8852BE, 2x2, 802.11ax, MU-MIMO, Bluetooth® wireless card <p>Primary Battery</p> <ul style="list-style-type: none"> -4 Cell, 54 Wh, integrated <p>Power</p> <ul style="list-style-type: none"> -65W AC adapter <p>Palmrest</p> <ul style="list-style-type: none"> -Ice Blue Power Button with Fingerprint Reader <p>Dell, HP or equivalent</p>		
07	12.9-inch iPad Pro Wi-Fi		10	SET

Appendix F

Revised Section 6 for package 0148

S/N	Key Items	Specifications	Quantity	UOM
		 <p>12.9-inch iPad Pro</p> <p>Finish: Silver, Space Grey</p> <p>Capacity:</p> <ul style="list-style-type: none"> - 2TB <p>Size and Weight:</p> <p>11-inch iPad Pro:</p> <ul style="list-style-type: none"> - Width: 178.5mm - Height: 247.6mm - Depth: 5.9mm - Wi-Fi models: 466g - Wi-Fi + Cellular models: 468g <p>12.9-inch iPad Pro:</p> <ul style="list-style-type: none"> - Width: 214.9mm - Height: 280.6mm - Depth: 6.4mm - Wi-Fi models: 682g - Wi-Fi + Cellular models: 684g <p>Buttons and Connectors:</p> <ul style="list-style-type: none"> - Speaker: Three - Microphones: Three - Top Button - Camera - Microphone - Volume Up/Down - Magnetic Connector - Nano-SIM Tray - Smart Connector - Thunderbolt/USB 4 		

Appendix F

Revised Section 6 for package 0148

S/N	Key Items	Specifications	Quantity	UOM
		<p>In the Box:</p> <ul style="list-style-type: none"> - iPad Pro - USB-C Charge Cable (1 meter) - 20W USB-C Power Adapter <p>Display:</p> <p>11-inch:</p> <ul style="list-style-type: none"> - Liquid Retina Display - 11-inch (diagonal) LED-backlit Multi-Touch display with IPS technology - 2388x1668-pixel resolution at 264 pixels per inch (ppi) - ProMotion technology - Wide color display (P3) - True Tone display - Fingerprint-resistant oleophobic coating - Fully laminated display - Anti-reflective coating - 1.8% reflectivity - SDR brightness: 600 nits max - Supports Apple Pencil (2nd generation) - Supports Apple Pencil (USB-C) <p>12.9-inch:</p> <ul style="list-style-type: none"> - Liquid Retina XDR Display - 12.9-inch (diagonal) mini-LED-backlit Multi-Touch display with IPS technology - 2732x2048-pixel resolution at 264 pixels per inch (ppi) - ProMotion technology - Wide color display (P3) - True Tone display - Fingerprint-resistant oleophobic coating - Fully laminated display - Anti-reflective coating - 1.8% reflectivity - SDR brightness: 600 nits max - XDR brightness: 1,000 nits max full screen, 1,600 nits peak (HDR content only) - 1,000,000:1 contrast ratio - Supports Apple Pencil (2nd generation) - Supports Apple Pencil (USB-C) 		

Appendix F

Revised Section 6 for package 0148

S/N	Key Items	Specifications	Quantity	UOM
		<p>Chip:</p> <ul style="list-style-type: none"> - Apple M2 chip - 8-core CPU with 4 performance cores and 4 efficiency cores - 10-core GPU - 16-core Neural Engine - 100GB/s memory bandwidth - 8GB RAM on models with 128GB, 256GB, or 512GB storage - 16GB RAM on models with 1TB or 2TB storage - Media engine <p>Camera:</p> <ul style="list-style-type: none"> - Pro Camera System: Wide and Ultra Wide cameras - Wide: 12MP, <i>f</i>/1.8 aperture - Ultra Wide: 10MP, <i>f</i>/2.4 aperture and 125° field of view - 2x optical zoom out - Digital zoom up to 5x - Five-element lens (Wide and Ultra Wide) - Brighter True Tone flash - Panorama (up to 63MP) - Sapphire crystal lens cover - Autofocus with Focus Pixels (Wide) - Smart HDR 4 - Wide color capture for photos and Live Photos - Lens correction (Ultra Wide) - Advanced red-eye correction - Photo geotagging - Auto image stabilization - Burst mode - Image formats captured: HEIF and JPEG <p>Video Recording:</p> <ul style="list-style-type: none"> - 4K video recording at 24 fps, 25 fps, 30 fps, or 60 fps (Wide) - 1080p HD video recording at 25 fps, 30 fps, or 60 fps - 720p HD video recording at 30 fps - ProRes video recording up to 4K at 30 fps (1080p at 30 fps for 128GB storage) - 2x optical zoom out - Audio zoom 		

Appendix F

Revised Section 6 for package 0148

S/N	Key Items	Specifications	Quantity	UOM
		<ul style="list-style-type: none"> - Brighter True Tone flash - Slow-motion video support for 1080p at 120 fps or 240 fps - Time-lapse video with stabilization - Extended dynamic range for video up to 30 fps - Cinematic video stabilization (4K, 1080p, and 720p) - Continuous autofocus video - Playback zoom - Video formats recorded: HEVC and H.264 - Stereo recording <p>TrueDepth Camera:</p> <ul style="list-style-type: none"> - 12MP Ultra Wide camera, 122° field of view - <i>f</i>/2.4 aperture - Portrait mode with advanced bokeh and Depth Control - Portrait Lighting with six effects (Natural, Studio, Contour, Stage, Stage Mono, High-Key Mono) - Animoji and Memoji - Smart HDR 4 - 1080p HD video recording at 25 fps, 30 fps, or 60 fps - Time-lapse video with stabilization - Extended dynamic range for video up to 30 fps - Cinematic video stabilization (1080p and 720p) - Wide color capture for photos and Live Photos - Lens correction - Retina Flash - Auto image stabilization - Burst mode <p>Video Calling:</p> <ul style="list-style-type: none"> - FaceTime video - Center Stage - iPad to any FaceTime-enabled device over Wi-Fi or a mobile network <p>Audio Calling:</p> <ul style="list-style-type: none"> - FaceTime audio - iPad to any FaceTime-enabled device over Wi-Fi or a mobile 		

Appendix F

Revised Section 6 for package 0148

S/N	Key Items	Specifications	Quantity	UOM
		<p>network</p> <p>Speakers: - Four speaker audio</p> <p>Microphones: - Five studio-quality microphones for calls, video recording, and audio recording</p> <p>Mobile and Wireless: - All models: Wi-Fi 6E (802.11ax) with 2x2 MIMO; speeds up to 2.4 Gbps - Simultaneous dual band - Bluetooth 5.3 - Wi-Fi + Cellular models: 5G (sub-6 GHz) with 4x4 MIMO, Gigabit LTE with 4x4 MIMO and LAA</p> <p>Location: - All models: Digital compass, Wi-Fi, iBeacon micro-location - Wi-Fi + Cellular models: GPS/GNSS, Mobile data</p> <p>Sensors: - Face ID - LiDAR Scanner - Three-axis gyro - Accelerometer - Barometer - Ambient light sensor</p> <p>Charging and Expansion: - Thunderbolt / USB 4 port with support for charging, DisplayPort, Thunderbolt 3 (up to 40 Gbps), USB 4 (up to 40 Gbps), USB 3 (up to 10 Gbps)</p> <p>Display Support: - Supports full native resolution on the built-in display at millions of colors - Supports one external display with up to 6K resolution at 60Hz - Thunderbolt 3 digital video output</p>		

Appendix F

Revised Section 6 for package 0148

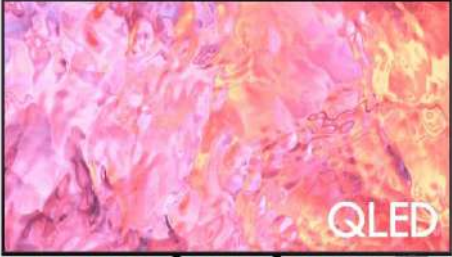
S/N	Key Items	Specifications	Quantity	UOM
		<ul style="list-style-type: none"> - Native DisplayPort output over USB-C - VGA, HDMI, DVI, and Thunderbolt 2 output supported using adapters (sold separately) - Video mirroring - Up to 4K AirPlay for mirroring, photos, and video out to Apple TV (2nd 		
08	85" QLED Smart TV	<div style="text-align: center;">  </div> <p>Product: QLED Series 6</p> <p>Display:</p> <ul style="list-style-type: none"> - Screen Size: 85" - Refresh Rate: 50Hz - Resolution: 4K (3,840 x 2,160) <p>Video:</p> <ul style="list-style-type: none"> - Picture Engine: Quantum Processor Lite 4K - One Billion Colour: Yes - HDR (High Dynamic Range): Quantum HDR - HDR 10+: Yes (ADAPTIVE) - HLG (Hybrid Log Gamma): Yes - Contrast: Dual LED - Colour: 100% Color Volume - Brightness/Colour Detection: Brightness Detection - Micro Dimming: Ultimate UHD Dimming - Contrast Enhancer: Yes - Film Mode: Yes - Motion Technology: Motion Xcelerator - Picture Clarity: Yes - Smart Calibration: Basic - Filmmaker Mode (FMM): Yes <p>Audio:</p> <ul style="list-style-type: none"> - Adaptive Sound: Adaptive Sound 	1	SET

Appendix F

Revised Section 6 for package 0148

S/N	Key Items	Specifications	Quantity	UOM
		<ul style="list-style-type: none"> - Object Tracking Sound: OTS Lite - Q-Symphony: Yes - Sound Output (RMS): 20W - Speaker Type: 2CH - Multiroom Link: Yes - Bluetooth Audio: Yes - Dual Audio Support (Bluetooth): Yes - Buds Auto Switch: Yes Smart Service (requires Samsung Account login): - Operating System: Tizen™ Smart TV - Bixby: US English, UK English, India English, Korean, French, German, Italian, Spanish, BR Portuguese (features vary by language) - Web Browser: Yes - SmartThings: Yes - Media Home: Yes Smart Feature: - Multi Device Experience: Mobile to TV, TV initiate mirroring, TV Sound to Mobile, Sound Mirroring, Wireless TV On, Tap View - Mobile Tap Mirroring: Yes - Multi-View: Up to 2 videos - Sound Wall: Yes - Mobile Camera Support: Yes - Easy Setup: Yes - App Casting: Yes - Ambient Mode: Ambient Mode - Wireless Dex: Yes - Cloud Service: Microsoft 365 - NFT: Nifty Gateway Differentiation: - Tune Station: Yes (Indonesia Only) - Analog Clean View: Yes - Triple Protection: Yes Game Feature: - Auto Game Mode (ALLM): Yes - Game Motion Plus: Yes - Super Ultra Wide Game View: Yes 		

Appendix F

Revised Section 6 for package 0148

S/N	Key Items	Specifications	Quantity	UOM
		<ul style="list-style-type: none"> - Mini Map Zoom: Yes - HGIG: Yes Tuner/Broadcasting: <ul style="list-style-type: none"> - Digital Broadcasting: DVB-T2 (*VN: DVB-T2C) - Analog Tuner: Yes - TV Key Support: Yes Connectivity: <ul style="list-style-type: none"> - HDMI: 3 - USB: 2 - Ethernet (LAN): 1 - Digital Audio Out (Optical): 1 - RF In (Terrestrial / Cable input / Satellite input): 1/1(Common Use for Terrestrial)/0 - Wi-Fi: Yes (WiFi5) - Bluetooth: Yes (BT5.2) - Anynet+ (HDMI-CEC): Yes - HDMI Audio Return Channel: eARC/ARC Design: <ul style="list-style-type: none"> - Design: AirSlim - Bezel Type: 3 Bezel-less - Slim Type: Slim look - Front Colour: BLACK - Stand Type: SIMPLE PLUS-WIDE - Stand Colour: BLACK Additional Feature: <ul style="list-style-type: none"> - Caption (Subtitle): Yes - EPG: Yes - ConnectShare™: Yes - Extended PVR: Yes - OSD Language: Local Languages - Teletext (TTX): Yes - Time Shift: Yes - MBR Support: Yes Accessibility: <ul style="list-style-type: none"> - Accessibility - Voice Guide: UK English, China Chinese, Korean, Indonesia, Vietnamese - Accessibility - Learn TV Remote / Learn Menu Screen: English, French, Spanish, Portuguese, Persian, Indonesian, Thai, Vietnamese, Arabic** Languages 		

Appendix F

Revised Section 6 for package 0148

S/N	Key Items	Specifications	Quantity	UOM
		<p>are supported if there is a language that matches the OSD language.</p> <ul style="list-style-type: none"> - Low Vision Support: Audio Description, Zoom Menu and Text, High Contrast, SeeColors, Color Inversion, Grayscale, Picture Off - Hearing Impaired Support: Closed Caption, Multi-output Audio, Sign Language Zoom - Motor Impaired Support: Slow Button Repeat <p>Power & Eco Solution:</p> <ul style="list-style-type: none"> - Eco Sensor: Yes - Power Supply: AC100-240V~50/60Hz - Power Consumption (Max): 285 W - Energy Efficiency Class: 4 - Power Consumption (Stand-by): 0.5 W - Power Consumption (Typical): 173 W - Yearly Power Consumption (EU standard): 316 kWh - Auto Power Off: Yes - Auto Power Saving: Yes <p>Dimension:</p> <ul style="list-style-type: none"> - Package Size (WxHxD): 2075 x 1247 x 220 mm - Set Size with Stand (WxHxD): 1900.9 x 1152.6 x 368.3 mm - Set Size without Stand (WxHxD): 1900.9 x 1085.7 x 26.9 mm - Stand (Basic) (WxD): 403.5 x 368.3 mm - VESA Spec: 600 x 400 mm <p>Weight:</p> <ul style="list-style-type: none"> - Package Weight: 55.9 kg - Set Weight with Stand: 43.1 kg - Set Weight without Stand: 41.5 kg <p>Accessory:</p> <ul style="list-style-type: none"> - Remote Controller Model: TM2360E - Slim Fit Wall Mount (Y22) Support: Yes - Vesa Wall Mount Support: Yes - User Manual: Yes 		

Appendix F

Revised Section 6 for package 0148

S/N	Key Items	Specifications	Quantity	UOM
		<ul style="list-style-type: none"> - Full Motion Slim Wall Mount (Y22): Yes - E-Manual: Yes - Webcam Support: Yes - Zigbee / Thread Module: Built-in - Power Cable: Yes <p>Samsung, LG or equivalent</p>		
09	LED Screen (1.5mm) (9 X 15)	 <ul style="list-style-type: none"> - Pixel pitch: 1.588 - Pixel per module: 384x216 (HxV) - Aspect ratio: 16:09 - LED lifetime: 100,000h (video - 80% brightness) - Brightness: >800 nit - Peak brightness: 1040 nit - Internal processing: 23 bit - Color depth: 16 bit (281 trillion colors) - Shaders: Yes - Control: Infinipix® Gen2 - Refresh rate: 3,840 Hz - 3D: 3D supported - Frame rate: 24 / 25 / 29.97 / 30 / 47.95 / 48 / 50 / 59.94 / 60 / 100 / 119.88 / 120 / 144 Hz - Hor. viewing angle: 160° +/-5° - Vert. viewing angle: 160° +/-5° - Brightness uniformity: >98% - Dimming: 0-100% - Contrast: >9,000:1 <p>Power consumption:</p> <ul style="list-style-type: none"> - 734 W/m² (max) - 154 W/Tile (max) - 228.3 W/m² (typ) 	1	SET

Appendix F

Revised Section 6 for package 0148

S/N	Key Items	Specifications	Quantity	UOM
		<p>- 48 W/Tile (typ)</p> <p>Heat dissipation: - 2501 BTU/h/m² (max) - 778 BTU/h/m² (typ)</p> <p>Ceiling configurations supported: Yes</p> <p>Heat dissipation front/back: 54%/46%</p> <p>Operation power voltage: - AC power: 100-240V 50/60Hz - DC power: Input: 36-55Vdc 16A (max.) Output: 36-55Vdc 10.72A/36V (max.) or 12.55A/55V (max.)</p> <p>Operational humidity: 10 -80%</p> <p>Operational temperature: -10°C to +40°C / 14°F to 104°F</p> <p>Storage temperature: -20°C to +50°C</p> <p>TAA Compliancy: Not available</p> <p>Storage humidity: 14 -85%</p> <p>IP rating: IP30</p> <p>Redundancy: - Power: Optional Standard on REM tiles - Data: Inter-tile and signal loop redundancy embedded / N + N redundancy optional</p> <p>HDR: HLG / HDR10 supported</p> <p>Concave curvature: - Up to 10° standard curved tile (3.5m radius) - Up to 5° curved modular tile (3.5m radius)</p> <p>Convex curvature: Up to 3° standard curved tile (12m radius)</p>		

Appendix F

Revised Section 6 for package 0148

S/N	Key Items	Specifications	Quantity	UOM
		<p>Dimensions (WxHxD): 609.92x343.08x71mm / 24.01"x13.5"x2.80"</p> <p>Weight: - Standard / curved tile: 8.3kg/tile (single PSU) / 8.7kg/tile (dual PSU) / 8.2kg/tile (REM PSU) - Modular curved tile: 9.1kg/tile (single PSU) 9.5kg/tile (dual PSU) / 9.0kg/tile (REM PSU)</p> <p>Serviceability: Full front & full back service Modular curved tile -Full front & full back service (PSU only back access)</p> <p>Cable management: No external cabling</p> <p>Installation: Self-leveling with surface tolerance compensation</p> <p>Module replacement: Automated parallel motorized extraction</p> <p>Module placement: Guided module placement</p> <p>Ergonomics: SteadyView™ driver algorithm to reduce eye fatigue</p> <p>Certifications: CE, UL, FCC class A, RoHS, WEEE, REACH, CCC, RCM</p> <p>TAA Compliancy: Optional</p>		
10	Media server Dell R550	 <p>Components:</p> <p>Base: - PowerEdge R550 Server</p> <p>Front Storage: - Chassis with up to 8x3.5" Drives</p>	1	SET

Appendix F

Revised Section 6 for package 0148

S/N	Key Items	Specifications	Quantity	UOM
		<p>Backplane: - SAS/SATA Backplane</p> <p>Trusted Platform Module: - Trusted Platform Module 2.0 V3</p> <p>Chassis: - 3.5" Chassis with up to 8 Hard Drives (SAS/SATA), 2 CPU</p> <p>Processor: - Intel® Xeon® Silver 4310 2.1G, 12C/24T, 10.4GT/s, 18M Cache, Turbo, HT (120W) DDR4-2666</p> <p>Additional Processor: - Intel® Xeon® Silver 4310 2.1G, 12C/24T, 10.4GT/s, 18M Cache, Turbo, HT (120W) DDR4-2666</p> <p>Processor Thermal Configuration: - Standard Heatsink for 2 CPU configuration</p> <p>Memory Configuration Type: - Performance Optimized</p> <p>Memory DIMM Type and Speed: - 3200MT/s RDIMMs</p> <p>Memory: - 16GB RDIMM, 3200MT/s, Dual Rank</p> <p>RAID: - C2, RAID 0 for HDDs or SSDs (Matching Type/Speed/Capacity)</p> <p>RAID/Internal Storage Controllers: - Front PERC H755 Front Load</p> <p>Storage: - 600GB Hard Drive SAS ISE 12Gbps 10k 512n 2.5in with 3.5in HYB CARR Hot-Plug (Qty: 2)</p> <p>PCIe Riser: - 2 CPU, 3x16 LP+ 1x8(x4 link) LP</p>		

Appendix F

Revised Section 6 for package 0148

S/N	Key Items	Specifications	Quantity	UOM
		<p>Motherboard:</p> <ul style="list-style-type: none"> - PowerEdge R550 Motherboard with Broadcom 5720 Dual Port 1Gb On-Board LOM <p>Boot Optimized Storage Cards:</p> <ul style="list-style-type: none"> - No BOSS Card <p>Quick Sync:</p> <ul style="list-style-type: none"> - Quick Sync 2 (At-the-box mgmt) <p>Password:</p> <ul style="list-style-type: none"> - iDRAC, Factory Generated Password <p>iDRAC Server Manager:</p> <ul style="list-style-type: none"> - iDRAC Service Module (ISM), NOT Installed <p>Group Manager:</p> <ul style="list-style-type: none"> - iDRAC Group Manager, Disabled <p>Virtualization:</p> <ul style="list-style-type: none"> - None <p>Internal SD Module:</p> <ul style="list-style-type: none"> - None <p>IDSDM Card Reader:</p> <ul style="list-style-type: none"> - None <p>Bezel:</p> <ul style="list-style-type: none"> - PowerEdge 2U Standard Bezel <p>OS & Software:</p> <p>Operating System:</p> <ul style="list-style-type: none"> - No Operating System <p>Secondary OS:</p> <ul style="list-style-type: none"> - None <p>OS Media Kits:</p> <ul style="list-style-type: none"> - No Media Required <p>Support Services:</p> <p>Support Services:</p> <ul style="list-style-type: none"> - Basic Next Business Day 36 Months, 36 Month(s) 		

Appendix F

Revised Section 6 for package 0148

S/N	Key Items	Specifications	Quantity	UOM
		<p>Services: Extended Service: - ProSupport and Next Business Day Onsite Service, 36 Month(s)</p> <p>Keep Your Hard Drive for Enterprise Services: - None</p> <p>Keep Your Component for Enterprise Services: - None</p> <p>Deployment Services:</p> <p>Infrastructure Deployment Svcs: - No Field Deployment Customer Install Required</p> <p>Dell Services: Deployment Services: - Infrastructure Deployment Selected</p> <p>ProDeploy Field Additional Deployment Services: - None</p> <p>Asset Report - Standard: - None</p> <p>BIOS Settings - Standard: - Power Management OS Control</p> <p>Data Migration Services: - None</p> <p>Data Sanitization or Destruction for Ent Service: - None</p> <p>Other Services:</p> <p>Infrastructure Consulting Services (ICS): - None</p> <p>Sftwr Svcs - Omnia Support: - None</p>		

Appendix F

Revised Section 6 for package 0148

S/N	Key Items	Specifications	Quantity	UOM
		<p>Custom Delivery Service: - APJ Dell White Gloves Services</p> <p>Regulatory:</p> <p>Product Safety and Environmental Datasheets: - Dell Regulatory Compliance Home Page</p>		
11	AV Solution for Video wall	 <p>Condition: New: A brand-new, unused, unopened, undamaged item in its original packaging (where packaging is applicable). Packaging should be the same as what is found in a retail store, unless the item is handmade or was packaged by the manufacturer in non-retail packaging, such as an unprinted box or plastic bag. See the seller's listing for full details. See all condition definitions opens in a new window or tab</p> <p>Brand: VDWALL</p> <p>Form Factor: LED video processor</p> <p>Custom Bundle: No</p> <p>Model: LVP615S+TS802D</p> <p>MPN: Does Not Apply</p> <p>Modified Item: No</p> <p>UPC: Does Not Apply</p>	1	SET
12 A	Holographic Avatar		1	SET

Appendix F

Revised Section 6 for package 0148

S/N	Key Items	Specifications	Quantity	UOM
		 <ul style="list-style-type: none"> - Human sized hologram - 3 units of 65cm fans - Material: ABS + PC + Aluminum - Connectivity: Wi-Fi, APP, PC - Memory: 16Gb SD Card built in - Input Voltage AC100-240V, 50/60HZ - Viewing Angle: 168° - Brightness: 2000 lumens - Contrast Ratio: 1000:1 - Response Time: 1s - Content format: MP4, AVI, RMVB, GIF 		
12 B	Holographic Screen		2	SET

Appendix F

Revised Section 6 for package 0148

S/N	Key Items	Specifications	Quantity	UOM
-----	-----------	----------------	----------	-----

		 <p>Supports multiple splicing</p> <ul style="list-style-type: none"> - 3D Hologram Fan Projector 100cm - Wi-Fi - Real-time 3D Advertising Display - Holographic Lamp Player Projector Fan - Support Ios Android - Suggested brand name: VIGAOT - Item Type: Advertising Light - Power Source: AC 100V~240V - Model: Advertising Display,3d hologram projector - Voltage: Output voltage: 24V - Lamp beads lifetime: 100,000 Hours - Content Format: MP4/AVI/GIF/JPG/PNG - Support: TF Card and Wi-Fi, remote control, drop screen - PC Operation System: Windows XP, Win7, Win8, Win10 - TF Memory card: 32GB 		
--	--	--	--	--

Appendix F

Revised Section 6 for package 0148

S/N	Key Items	Specifications	Quantity	UOM
		<ul style="list-style-type: none"> - Phone System: support IOS, Android 		
12 C	Holographic LED Fan	<div style="text-align: center;">  </div> <ul style="list-style-type: none"> - 224 LEDs two-axis rotating imaging, presenting naked-eye high-definition 3D visual effects. - Comes with A Very Large Video Library, Including Food, Universe, Sci-Fi, Animation, Cyber Etc. - Support APP+Bluetooth connection. - Support Customized 3D Logo & pictures. - Mobile phone synchronous screen projection function. - Multi-machine linkage + unlimited splicing: support unlimited splicing, large-scale linkage audio and video, unlimited size, more shocking display (requires other components) - Size: 41*41*3.8 cm/15.7*15.7*1.5 inches - Resolution: 640*640 - Viewing Angle: 160° - Output Voltage: 12V/2A - Power: 10 -15 W 	5	SET

Appendix F

Revised Section 6 for package 0148

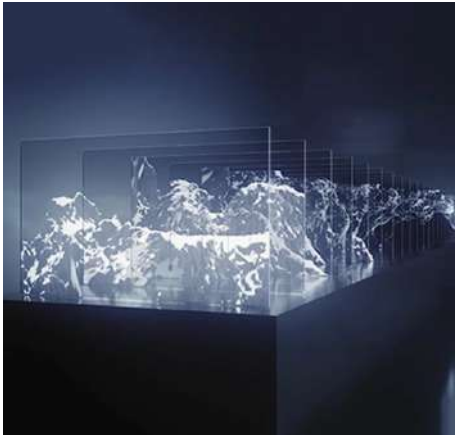
S/N	Key Items	Specifications	Quantity	UOM
		<ul style="list-style-type: none"> - Display Diameter: 40 cm/15.7in - LED Quantity: 224 pcs - Storage Capacity: 8 G - Support Format: MP4/JPG/GAIF/MOV - Supporting System: Windows/ iOS/ Android - Brightness adjustment: yes - Bluetooth audio: support 		
13	3D Screen Mesh	 <ul style="list-style-type: none"> - Can display vivid and clear images. - Wide viewing angle. - Performs exceptionally well even in high ambient lighting or bright daylight conditions. - True color reproduction from any angle. - Perfectly suitable for Videos, DVD and data projection. - Can be cut to any shape and size. - Lightweight and easy to install on glass of shop windows. - Can be applied to rigid & clear 	2	SET

Appendix F

Revised Section 6 for package 0148

S/N	Key Items	Specifications	Quantity	UOM
		<p>acrylic panels to create easily portable displays.</p> <ul style="list-style-type: none"> - Material: PVC - Portable: Yes - Format: 4:3 - Suggested Brand: Yovanxer - Type: Rear projection film - Projection Area: 1.52 x 1.52m 		
14	Floor Interactive Projection System	 <ul style="list-style-type: none"> - Product name: Interactive Floor & Wall Projection Games - Suggested Brand Name: OneCraze -Suggested Model Number: CY-DM-002 - Max Resolution: 1920 x 1080 - Interactive Scenes: 200+ - Interface type: USB or WiFi - Brightness: 5000 lumens - Projection area: 5 x 3m - Throw Ratio: 0.44, 0.6-0.8, 1.08-1.76, 1.2-2.0 - Include software, sensor, tracker, 	1	SET

Appendix F
Revised Section 6 for package 0148

S/N	Key Items	Specifications	Quantity	UOM
		cable and accessories		

Appendix - G

Revised Section 6 for Package 0152

As per existing Bid Document						Revised					
SI No	Item No	Item	Specification	Qty	Unit	Item	Specification	Qty	Unit		
1	A1	The External Training Console	<p>Soft Control keyboard operated via Mouse or Touch (with interchangeable key modules) for the respective controller / family / type), that could make the operation easier & bring a higher didactic value by its similarity to the original controller. The external training console should be designed for milling and turning machines, including machine controller base unit with USB interface.</p> 	40+1	Nos	Remains same as per the Original Bid Document	<p>The offline CNC simulator module shall be a complete setup of hardware and software-based training solution for CNC machining. The simulator shall be capable of simulating operation of the CNC controller in real life environment. Operation and handling similar to the real-life machine controller shall ensure that a CNC program generated with the setup (hardware and software) shall be able to run on the CNC machine.</p> <table border="1" style="width: 100%; margin-top: 10px;"> <tr> <td style="width: 5%;">1.1</td> <td>The set-up shall be suitable for conducting training on CNC milling and turning machines with Fanuc 31i T M, Sinumerik Operate with Shop turn & Shop mill, HEIDENHAIN TNC 640-M, Fagor 8055 Turn+Mill controller families/ types and up-gradable to latest versions at free of cost for 10 years. The software must be able to run independently,</td> </tr> </table>	1.1	The set-up shall be suitable for conducting training on CNC milling and turning machines with Fanuc 31i T M, Sinumerik Operate with Shop turn & Shop mill, HEIDENHAIN TNC 640-M, Fagor 8055 Turn+Mill controller families/ types and up-gradable to latest versions at free of cost for 10 years. The software must be able to run independently,	No Change	No Change
1.1	The set-up shall be suitable for conducting training on CNC milling and turning machines with Fanuc 31i T M, Sinumerik Operate with Shop turn & Shop mill, HEIDENHAIN TNC 640-M, Fagor 8055 Turn+Mill controller families/ types and up-gradable to latest versions at free of cost for 10 years. The software must be able to run independently,										

Appendix - G

Revised Section 6 for Package 0152

As per existing Bid Document						Revised															
SI No	Item No	Item	Specification	Qty	Unit	Item	Specification	Qty	Unit												
			<table border="1"> <tr> <td>1</td> <td>Must provide for the following controls and technologies: - Fanuc turning and milling. - Siemens 840 D Turning and milling. - Heidenhain TNC640 Turning and milling. - Fagor 8055 Turning and milling.</td> </tr> <tr> <td>2</td> <td>The control panel with common base unit for all the above controls, must have interchangeable top key panels and easy to install</td> </tr> <tr> <td>3</td> <td>Top key panels must be resistance</td> </tr> </table>	1	Must provide for the following controls and technologies: - Fanuc turning and milling. - Siemens 840 D Turning and milling. - Heidenhain TNC640 Turning and milling. - Fagor 8055 Turning and milling.	2	The control panel with common base unit for all the above controls, must have interchangeable top key panels and easy to install	3	Top key panels must be resistance				<table border="1"> <tr> <td></td> <td>especially on PCs without machines.</td> </tr> <tr> <td>1.2</td> <td>The control panel with common base unit for all the above controls, must have interchangeable top key panels and easy to install.</td> </tr> <tr> <td>1.3</td> <td>Didactic Software The Interactive didactic software shall be user-friendly, efficient, and secure all-round solution for computerized training. The software shall be capable of <ul style="list-style-type: none"> • Broadcasting and sharing of the Screen with the classroom • Controlling access • Evaluation of work carried out by the students • Share audio & video facility • Lock screens • Share files • Chatting/Message Transfer </td> </tr> </table>		especially on PCs without machines.	1.2	The control panel with common base unit for all the above controls, must have interchangeable top key panels and easy to install.	1.3	Didactic Software The Interactive didactic software shall be user-friendly, efficient, and secure all-round solution for computerized training. The software shall be capable of <ul style="list-style-type: none"> • Broadcasting and sharing of the Screen with the classroom • Controlling access • Evaluation of work carried out by the students • Share audio & video facility • Lock screens • Share files • Chatting/Message Transfer 		
1	Must provide for the following controls and technologies: - Fanuc turning and milling. - Siemens 840 D Turning and milling. - Heidenhain TNC640 Turning and milling. - Fagor 8055 Turning and milling.																				
2	The control panel with common base unit for all the above controls, must have interchangeable top key panels and easy to install																				
3	Top key panels must be resistance																				
	especially on PCs without machines.																				
1.2	The control panel with common base unit for all the above controls, must have interchangeable top key panels and easy to install.																				
1.3	Didactic Software The Interactive didactic software shall be user-friendly, efficient, and secure all-round solution for computerized training. The software shall be capable of <ul style="list-style-type: none"> • Broadcasting and sharing of the Screen with the classroom • Controlling access • Evaluation of work carried out by the students • Share audio & video facility • Lock screens • Share files • Chatting/Message Transfer 																				

Appendix - G

Revised Section 6 for Package 0152

As per existing Bid Document						Revised			
SI No	Item No	Item	Specification	Qty	Unit	Item	Specification	Qty	Unit
			to entry of dust and liquids.				<ul style="list-style-type: none"> Perform in an interactive whiteboard environment 		
			4 Control Panels must be of plug and play type with the above software's and standalone solutions for Fanuc, Siemens and Heidenhain				1.4 PC & Networking Compatibility: OS- (Latest MS-Windows Operating system): TCP/IP network		
			5 Possible to Connection via USB interface				2 Off-line Training software (1 Teacher + 40 students)		
			6 Communicate and work together with relevant product individual virtual panels				2.1 License for following controller families / types (Teacher with Smart Interactive Touch Panel) <ul style="list-style-type: none"> Sinumerik Operate 828D FANUC Series 31i HEIDENHAIN TNC 640 M Fagor 8055 		
			6 PC System requirement to be provided suitable for the above software				2.2(A) Following features for Consoles. Teacher Console with Following features: Console with 55 inches (Minimum) touch panel Screen & Built-in Data		

Appendix - G

Revised Section 6 for Package 0152

As per existing Bid Document						Revised			
SI No	Item No	Item	Specification	Qty	Unit	Item	Specification	Qty	Unit
							<p>Processing Unit. Will be Sheet Metal fabricated floor console unit with Programing & Machine control keyboard with following features:</p> <p>The stand-alone floor mounted, system including CNC lathe and Milling SOFTWARE</p> <p>Fanuc 31i Turn+ Mill, Sinumerik Operate 828D Turn+ Mill with Shop turn & Shop mill, HEIDENHAIN TNC 640Mill & Fagor 8055 Turn+ Mill controller families/ types and up-gradable free for life. The software must be able to run independently, especially on PCs without machines. The system shall have a Soft Touch ON screen control keyboard with interchangeable key modules for the respective controller mentioned in</p>		

Appendix - G

Revised Section 6 for Package 0152

As per existing Bid Document						Revised			
SI No	Item No	Item	Specification	Qty	Unit	Item	Specification	Qty	Unit
							<p>family / type, that could make the operation easier & bring a higher didactic value by its similarity to the original controller. The training console designed for milling and turning machines, including machine control base unit and and USB interface.</p> <p>CONSTRUCTION OF CONSOLE: TEACHER 55 inches touch. INTERACTIVE FLAT PANEL with specs:</p> <ul style="list-style-type: none"> • Smart touch technology • write, save and e-mail • Interactive white board and Pen • Mobile connectivity • 4K UHD Resolution or better <p>USB type C - connectivity</p>		

Appendix - G

Revised Section 6 for Package 0152

As per existing Bid Document						Revised			
SI No	Item No	Item	Specification	Qty	Unit	Item	Specification	Qty	Unit
							<ul style="list-style-type: none"> • HDCP should be activated BIS, CE, FCC, ROHS certified. • Memory RAM 4GB, ROM 64 GB. ISO 9001 & 27001 CERTIFIED Data Processing Unit: <ul style="list-style-type: none"> a. CPU : Intel Celeron 1.5Ghz (Minimum) b. RAM : 8 GB DDRL(Minimum) c. SSD : 256 GB (Minimum) d. Graphics: Intel HD Graphics e. OS:Windows 10 operating system f. Audio Port should be available. g. USBPort-3(Minimum) h. HDMI Port 1(Minimum) i. VGA Port 1(Minimum) j. Audio Port: For Audio out/Mic-in k. Lan RJ45 1 Minimum 		

Appendix - G

Revised Section 6 for Package 0152

As per existing Bid Document						Revised			
SI No	Item No	Item	Specification	Qty	Unit	Item	Specification	Qty	Unit
							l. Wi-Fi m. Compartable Networking Software Machine Control keyboard:- Should be designed for milling and turning machines, including with axis buttons, feed override knob (select feed from 0- 120%) and Machine Operation Key (i/e Reference, EDIT, AUTO, MDI, JOG, INC mode) on controller base unit with USB interface		
							2.2(B) Student Console: A single Unit with Following features with touch Screen. A) Touch Screen 1. ScreenSize:24 inches (Minimum) 2. Display Type: LCD 3. Display Panel Diagonal size(mm):550 (Minimum)		

Appendix - G

Revised Section 6 for Package 0152

As per existing Bid Document						Revised			
SI No	Item No	Item	Specification	Qty	Unit	Item	Specification	Qty	Unit
							4. Width of The Effective Display Area of The Panel(mm): 526Minimum) 5. Height of The Effective Display Area of The Panel (mm):295 (Min) 6. Backlight Technology: LED 7. Display: Resolution(Pixels) 1920X1080(Minimum) 8.Display Brightness(Nits):250(Minimum) 9. Touch interface:Touch sensitive(Full) 10. Touch Technology: Capacitive 11. Response time(milli seconds):5 (Minimum) 12.Operating System Compatibility: Windows10(Minimum) 13. NumberofInputHDMIports:1(Minimum) 14. NumberofUSB2.0 ports(Nos.): 1(Minimum)		

Appendix - G

Revised Section 6 for Package 0152

As per existing Bid Document						Revised			
SI No	Item No	Item	Specification	Qty	Unit	Item	Specification	Qty	Unit
							15. Power Supply Voltage inAC(Volts): 100-240 16. Power consumption (Watts): 23(Max.) 17. Operating Temperature Range (Degree Celsius): 0-50 B-Data Processing Unit:- a. CPU : Intel Celeron 1.5Ghz (Minimum) b. RAM : 8GB DDRL(Minimum) c. SSD : 256 GB (Minimum) d. Graphics: Intel HD Graphics e. OS:Windows 10 f. Audio Port should be available. g. USBPort-3(Minimum) h. HDMIPort 1(Minimum) i. VGAPort 1(Minimum) j. AudioPort: For Audio out/Mic-in k. Lan RJ45 1 Minimum		

Appendix - G

Revised Section 6 for Package 0152

As per existing Bid Document						Revised			
SI No	Item No	Item	Specification	Qty	Unit	Item	Specification	Qty	Unit
							l. Wi-Fi m. Compartable Networking Software C- Machine Control keyboard:- Should be designed for milling and turning machines, including with axis buttons, feed override knob (select feed from 0- 120%) and Machine Operation Key (i/e Reference, EDIT, AUTO, MDI, JOG, INC mode) on controller base unit with USB interface.		
						2.3	With 41 seats 3D-Graphic Simulation Software Turning / Milling 3D graphic simulation software licenses (Note : Shall be compatible with above mentioned controller families / types)		
						3	Controller Families / Types		
						3.1	Fanuc 31i Turn +Mill		

Appendix - G

Revised Section 6 for Package 0152

As per existing Bid Document						Revised			
SI No	Item No	Item	Specification	Qty	Unit	Item	Specification	Qty	Unit
							Sinumerik 828D Turn+ Mill Heidenhain (iTNC 640) Mill Fagor 8055 Turn + Mill		
						4	CNC Simulator		
							4.1 The Simulator shall be Industrial type with onscreen soft key interchangeable keyboard facility for the specified "Controller Families / Types". 4.2 Must have on screen soft key industrial type interchangeable programming Module. (Digitizer type not accepted) 4.3 Programming function keys should be vertically placed to get the feel of industrial type programming panel and should exactly match to industrial machine control panel.		

Appendix - G

Revised Section 6 for Package 0152

As per existing Bid Document						Revised			
SI No	Item No	Item	Specification	Qty	Unit	Item	Specification	Qty	Unit
							4.4 Shall have feed override knob (select feed from 0-120%) 4.5 Mode Select Key (select Modes: i/e Reference, EDIT, AUTO, MDI, JOG, INC mode) 4.6 USB Interface for PC connectivity. 4.7 On-screen display of control-specific and machine keyboard 4.8 Operation is performed using a mouse or a touch on the screen monitor 4.9 Easy and quick to configure 4.10 Hardware to control the machine with axis buttons, feed override switch etc.		
						5	Details Specification of CNCOffline programming Software		
							5.1 Offline programming station shall provided with on screen interchangeable key-modules for		

Appendix - G

Revised Section 6 for Package 0152

As per existing Bid Document						Revised			
SI N o	Item No	Item	Specification	Qty	Unit	Item	Specification	Qty	Unit
							the respective Controller family / Type. 5.2 Graphic simulation in 2D/3D graphics with zooming facility. 5.3 Detailed error message about programming faults / errors. 5.4 Language: English 5.5 Program generate: Main programs, subroutines, tool data register and work piece management shall be auto stored 5.6 Control system: PC based control for Turning and Milling 5.7 Operations: Linear, circular, helical and thread interpolation, Pocket, etc. 5.8 Operating System Should support on Latest MS windows operating system. 5.9 License Type : Perpetual 5.10 Programming "C" axis on CNC lathes		

Appendix - G

Revised Section 6 for Package 0152

As per existing Bid Document						Revised			
SI No	Item No	Item	Specification	Qty	Unit	Item	Specification	Qty	Unit
							5.11 Programming "4th" axis on CNC milling		
						6	Following cycle shall be supported on FANUC 31i or Latest -Turning Controller		
							6.1 Finishing cycle 6.2 Turning cycle 6.3 Facing cycle 6.4 Pattern repeating 6.5 Boring Cycle 6.6 Grooving cycle 6.7 Threading cycle 6.8 Cancel drilling cycle 6.9 Drilling cycle 6.10 Tapping cycle 6.11 Reaming cycle 6.12 End Sub program		
						7	Following Cycle shall be supported on FANUC 31i or Latest - Milling Controller		
							7.1 Chip Break drilling cycle 7.2 Cancel drilling cycle 7.3 Drilling cycle		

Appendix - G

Revised Section 6 for Package 0152

As per existing Bid Document						Revised			
SI No	Item No	Item	Specification	Qty	Unit	Item	Specification	Qty	Unit
							7.4 Drilling cycle with dwell time 7.5 Deep hole drilling cycle 7.6 Taping cycle 7.7 Reaming cycle 7.8 Drilling cycle with spindle stop 7.9 pack drilling cycle 7.10 Drilling cycle with program stop 7.11 Reaming cycle with dwell time 7.12 Scale / Mirror factor 7.13 Coordinate system ON 7.14 Coordinate system OFF 7.15 Call Sub programming 7.16 End Sub program 7.17 Macro Programming		
						8	Following cycle shall be supported on SINUMERIK 828D or latest Turning Controller		
							8.1 Drilling, centring		
							8.2 Drilling, counter boring		

Appendix - G

Revised Section 6 for Package 0152

As per existing Bid Document						Revised			
SI No	Item No	Item	Specification	Qty	Unit	Item	Specification	Qty	Unit
							8.3 Deep-hole drilling 8.4 cycle (deep-hole drilling) 8.5 cycle (rigid tapping without using a floating tap holder) 8.6 Rigid tapping without using a floating tap holder 8.7 Tapping with floating tap holder 8.8 Recessing cycle 8.9 Undercutting cycle 8.10 Stock removal cycle 8.11 Thread undercut cycle 8.12 Thread cutting cycle 8.13 Chaining of threads		
						9	Following cycle shall be supported on SINUMERIK 828D or latest Milling Controller		
							9.1 Contour milling 9.2 Surface milling 9.3 Drilling, centring 9.4 Drilling, counter boring 9.5 Deep-hole drilling 9.6 Rigid tapping without using a floating tap holder 9.7 Tapping with floating tap holder 9.8 Hole circle 9.9 Thread milling 9.10 Slots on a circle		

Appendix - G

Revised Section 6 for Package 0152

As per existing Bid Document						Revised			
SI No	Item No	Item	Specification	Qty	Unit	Item	Specification	Qty	Unit
							9.11 Rectangular pocket milling cycle 9.12 Circular pocket milling cycle 9.13 Special rectangular pocket milling cycle 9.14 Special circular pocket milling cycle		
						10	Following cycle shall be support on HEIDENHAIN TNC 640 – Milling Controller		
							10.1 Drilling / Thread Cycle for Drilling, Tapping and Thread Milling 10.2 Pocket /Studs/Slots cycle for Milling pockets, Studs and Slots 10.3 Pattern cycle for Machining Holes patterns 10.4 SL-Cycle 10.5 Multipage Cycle for Multipass milling 10.6 Coordinate transformation cycle for Coordinate transformation 10.7 Special Cycle for well type, program calls, oriented spindle stop. 10.8 Line :L 10.9 Chamfer : CHF 10.10 Circle Center :CC 10.11 Circle : C 10.12 Circle by Radius : CR		

Appendix - G

Revised Section 6 for Package 0152

As per existing Bid Document						Revised			
SI No	Item No	Item	Specification	Qty	Unit	Item	Specification	Qty	Unit
							10.13 Corner rounding : RND 10.14 Free Contour Programming : FK 10.15 Window Oriented, Modern user interface. 10.16 Drilling / Thread Cycle for Drilling, Tapping and Thread Milling 10.17 Pocket /Studs/Slots cycle for Milling pockets, Studs and Slots 10.18 Pattern cycle for Machining Holes patterns 10.19 SL-Cycle Cycle for complex contours 10.20 Multipage Cycle for Multipass milling 10.21 Coordinate transformation cycle for Coordinate transformation 10.22 Contour Milling Cycles 10.23 Contour Finishing Depth Cycles 10.24 Contour Finishing Side Cycles 10.25 Mirroring 10.26 Rotation 10.27 Helix 10.28 Datum Setting 10.29 SL Cycles		

Appendix - G

Revised Section 6 for Package 0152

As per existing Bid Document						Revised			
SI N o	Ite m No	Item	Specification	Qty	Unit	Item	Specification	Qty	Unit
							10.30 Horizontal and vertical control via soft keys like the industry control Heidenhain controller.		
						11	Following cycle shall be support on Fagor 8055 – Milling Controller		
							11.1 Positioning 1		
							11.2 Positioning 2		
							11.3 Surface Milling		
							11.4 Grooving		
							11.5 Profile 1		
							11.6 Profile 2		
							11.7 Profiling		
							11.8 Profile Pocket 2D		
							11.9 Rectangular Boss		
							11.10 Round Boss		
							11.11 Simple Pocket		
							11.12 Rectangular Pocket		
							11.13 Circular Pocket 1		
							11.14 Circular Pocket 2		
							11.15 Boring 1		
							11.16 Boring 2		
							11.17 Reaming		
							11.18 Tapping		
							11.19 Drilling 1		
							11.20 Drilling 2		
							11.21 Drilling 3		

Appendix - G

Revised Section 6 for Package 0152

As per existing Bid Document						Revised			
SI No	Item No	Item	Specification	Qty	Unit	Item	Specification	Qty	Unit
							11.22 Centre Punch		
						12	Following cycle shall be support on Fagor 8055 – Turning Controller		
							12.1 Positioning Cycle1		
							12.2 Positioning Cycle 2		
							12.3 Turning Cycle 1 / 2		
							12.4 Facing Cycle 1 / 2		
							12.5 Profiling Cycle 1		
							12.6 Profiling Cycle 2		
							12.7 Profiling Cycle XC		
							12.8 Profiling Cycle ZC		
							12.9 Threading Cycle 1		
							12.10 Threading Cycle 2		
							12.11 Threading Cycle 3		
							12.12 Thread Repair Cycle		
							12.13 Taper Cycle 1 /2 /3		
							12.14 Rounding Cycle 1		
							12.15 Rounding Cycle 2		
							12.16 Grooving Cycle 1 / 2		
							12.17 Grooving Cycle 3 / 4		
							12.18 Cut-off Cycle		
							12.19 Drilling Cycle		
							12.20 Tapping Cycle		
							12.21 Multiple Drilling		
							12.22 Multiple Tapping		
							12.23 Multiple Slot Milling		

Appendix - G

Revised Section 6 for Package 0152

As per existing Bid Document						Revised									
S I N O	Ite m No	Item	Specification	Qty	Unit	Item	Specification	Qty	Unit						
2	A2	Virtual CNC Simulation Software	<p>The Virtual CNC Simulation Software shall be user-friendly, efficient, and secure allround solution for computerized training. The software shall be capable of</p> <ul style="list-style-type: none"> • Broadcasting and sharing of the Screen with the classroom • Controlling access • Evaluation of work carried out by the students • Perform in an interactive whiteboard environment 	40+1	Nos	Remains same as per the Original Bid Document	<p>Software for CNC machine simulator must simulate the entire CNC machine VMC or CNC Lathe and its CNC console keyboard together in one screen. CNC systems to be available for Turning and milling FANUC, Haas ST, SINUMERIK 840D T, 828D, FAGOR 8055, MITSUBISHI M70, latest version.</p> <table border="1" style="width: 100%; border-collapse: collapse;"> <thead> <tr> <th style="text-align: center;">S.No</th> <th style="text-align: center;">Description</th> </tr> </thead> <tbody> <tr> <td></td> <td>Software for CNC Programming & Simulation</td> </tr> <tr> <td style="text-align: center;">1</td> <td>CNC machine simulator must simulate the entire CNC machine VMC or CNC Lathe and its CNC console keyboard together in one screen. CNC systems to be available for Turning and milling FANUC, Haas ST, SINUMERIK 840D T, 828D, FAGOR 8055, MITSUBISHI M70, latest version.</td> </tr> </tbody> </table>	S.No	Description		Software for CNC Programming & Simulation	1	CNC machine simulator must simulate the entire CNC machine VMC or CNC Lathe and its CNC console keyboard together in one screen. CNC systems to be available for Turning and milling FANUC, Haas ST, SINUMERIK 840D T, 828D, FAGOR 8055, MITSUBISHI M70, latest version.	No Change	No Change
S.No	Description														
	Software for CNC Programming & Simulation														
1	CNC machine simulator must simulate the entire CNC machine VMC or CNC Lathe and its CNC console keyboard together in one screen. CNC systems to be available for Turning and milling FANUC, Haas ST, SINUMERIK 840D T, 828D, FAGOR 8055, MITSUBISHI M70, latest version.														
			<table border="1" style="width: 100%; border-collapse: collapse;"> <tr> <td style="text-align: center;">A</td> <td>Software for CNC Programming & Simulation</td> </tr> </table>	A	Software for CNC Programming & Simulation										
A	Software for CNC Programming & Simulation														

Appendix - G

Revised Section 6 for Package 0152

As per existing Bid Document						Revised			
SI No	Item No	Item	Specification	Qty	Unit	Item	Specification	Qty	Unit
			1 Software capable of 100% real CNC machine data to simulate and programming projects on Windows PC's				2 Machine simulation must show the entire CNC machine, VMC or CNC Lathe, Part, work holding, Cutting tool, turret/ATC		
			2 No emulation software data accepted of NC, PLC and 3D components, must use original control data and components				3 Student must be able to use software interactively using the virtual CNC console keyboard with a mouse or touch screen.		
			3 Total PLC and NC integration of CNC controls Siemens 840 D, Heidenhair TNC 640 and Fagor 8055				4 Student must be able to select a X/Z – axis on CNC Lathe & X/Z/Y/C/A - axis on CNC VMC. As per choice.		
			4 All control cycles and PLC functions must work in the simulation system as				5 In VMC mode. Must allow selection of replicas of Fanuc. Siemens, Mitsubishi, Fagor CNC console panels as listed above.		

Appendix - G

Revised Section 6 for Package 0152

As per existing Bid Document						Revised			
SI No	Item No	Item	Specification	Qty	Unit	Item	Specification	Qty	Unit
			<p>on the real machine, e.g.:</p> <p>a. All NC cycles like roughing, drilling, milling, threading etc.</p> <p>b. All M-Functions like the tool change, pallet-change, tool measuring methods, zero-point detection, tool data change process must be based on real PLC functions and processes</p> <p>c. Software should have enhanced feature to program and simulate Manufacturer technology cycles</p>				<p>6 In CNC lathe mode. Must allow selection of replicas of Fanuc, Siemens, Mitsubishi, Fagor CNC console panels as listed above.</p> <p>7 Must seamlessly interface and integrate with the interactive CNC programming software to run the programs internally.</p> <p>8 Must simulate Fanuc, Siemens, Mitsubishi, Fagor CNC console panels exactly, with same keyboard layout and logic.</p> <p>9 Software must have operation modes, memory, edit, MDI, Jog, and incremental jog.</p>		

Appendix - G

Revised Section 6 for Package 0152

As per existing Bid Document						Revised			
SI No	Item No	Item	Specification	Qty	Unit	Item	Specification	Qty	Unit
			for milling and turning e.g Alternate speed cycle, keyway broaching etc				10 Software must have keys for emergency stop, edit lock, cycle start & stop, reset.		
			5 Manual data-, JOG- and MDA - modes must be available and shown as on the real machine				11 Software must have keys for spindle start/stop, tool change, coolant on/off and program editing soft keys.		
			6 NC programs, tool data input must be created as on the real controls and machines				12 Software must have controls for feed rate override, spindle speed override, MPG.		
			7 The simulation area must cover a 3D removal simulation, operations of auxiliary aggregates like tailstock, steady rest, tool and pallet change,				13 Alarms must be displayed on cycle start without closing door, on tool collision, axis over-travel.		
							14 Entire VMC or CNC lathe machine must be simulated in 3D graphics with rotation, zoom, pan of machine views.		
							15 Must simulate G-codes and M-codes, canned cycles, subprograms.		

Appendix - G

Revised Section 6 for Package 0152

As per existing Bid Document						Revised			
SI No	Item No	Item	Specification	Qty	Unit	Item	Specification	Qty	Unit
			<p>manual operations, workspace inspection, measuring probes, etc.</p> <p>8 Machine collisions between tools, clamping devices, machine tables, chucks and all other relevant objects must be shown and marked</p> <p>9 3D machine data for tool and clamping devices must be import by 3D CAD formats like stp, stl, etc.</p> <p>10 Fully CAD system must be available on teacher seat</p> <p>11 On all versions a parametric menu</p>				<p>16 Must simulate part mounting, tool offsets and work offsets setting by methods used in industry.</p> <p>17 Simulation must show flow of chips, coolant, with realistic sounds of machining operations.</p> <p>18 Video recording, storage and replay of simulation must be possible for off-line skill assessment.</p> <p>19 Must be able to select tools from database and insert them in required turret position</p> <p>20 Must be able to add turning, Grooving, Threading, Drilling tools for lathes.</p> <p>21 Must be able to add face mill, end mill, drill, centre drill, tap, boring tools for VMC.</p> <p>22 On-screen measurement of part must be possible for tool offsets setting and</p>		

Appendix - G

Revised Section 6 for Package 0152

As per existing Bid Document						Revised			
SI No	Item No	Item	Specification	Qty	Unit	Item	Specification	Qty	Unit
							inspection		
			12 must be available to create 3D devices				23 Must support touch screen monitors for realistic learning,		
			13 A virtual machine keypad must be available as a standard and an interface to connect physical machine consoles				24 Must support dual monitors. CNC console on one screen and machine on other screen. System for assessment of learning outcomes.		
			14 Real cycle time evaluation				25 Instructor must be able to assist students via remote view or take control of a student's PC		
			14 Machine library must be considered: o 3 axis and 5 axis machines with Siemens 840 D tool capacity of >=30 tools o 3 axis and 5 axis Heidenhain TNC 640 tool capacity of >=30 tools o Universal turning machines with X,				26 Students and instructors must be able to login with unique user name and password.		
							27 Instructors must be able to add own exercises and send & receive exercises to/ from students.		
							28 Software must have test management facility with automatic marking and storage of marks.		
							29 Must have test questions library management facility for test paper management.		

Appendix - G

Revised Section 6 for Package 0152

As per existing Bid Document						Revised			
SI No	Item No	Item	Specification	Qty	Unit	Item	Specification	Qty	Unit
			Z, C, Y-axis and Turret and tailstock o Turn Mill machine with X, Z, C, Y, B- axis, Fully 5 axis simultaneous operations with tool capacity of >=30 tools				30 Test questions must be configurable: multiple choice, fill-in-blanks, long answer type.		
			15 Language: English				31 Instructor must be able to add, modify or delete questions in the library at any time.		
			B Software for Fanuc programming & Training fulfilling the following requirements by an external identical programming software				32 HELP Menu: This section must have details/description about Lathe & Mill Machines, minimal construction of same, various parts & tools, should follow the parameters of syllabus set by ITI curriculum.		
			1 Software capable of 100% real CNC machine data to simulate and programming				Multimedia Teach ware/Course ware for CNC Technology: - The software should enable teaching of CNC Turning and CNC milling technology aligned with CTS syllabus prescribed by DGT in a highly effective manner through multimedia such as Videos, animation, sound, pictures, 3D interactive graphics and text explanations. Software must use Video clips from actual machines, cutting tools and machining situations in industry to enable the student to interactively learn and understand how CNC machines are used in		

Appendix - G

Revised Section 6 for Package 0152

As per existing Bid Document						Revised			
SI No	Item No	Item	Specification	Qty	Unit	Item	Specification	Qty	Unit
			<p>projects on Windows PC's</p> <p>2 No emulation software data accepted of NC, PLC and 3D components, must use original control data and components</p> <p>3 Simulate standard CNC programs includes all available cycles, allowing users to generate even complex parts.</p> <p>4 The shopfloor programming software MANUAL GUIDE I must be included</p> <p>5 Even available for 30i series, Series 30i - MODEL B series 31i -</p>				industry and establish a link between theory and practice.		

Appendix - G

Revised Section 6 for Package 0152

As per existing Bid Document						Revised			
SI No	Item No	Item	Specification	Qty	Unit	Item	Specification	Qty	Unit
			MODEL B, Series 31i - MODEL B5, Series 32i - MODEL B						
			6 Series 31i - MODEL A, Oi series, Series Oi - TD / MD, Series Oi - TF / MF, Series Oi - TF / MF Plus						
			7 Automatic Cycle Time calculation						
			8 A virtual machine keypad must be available as a standard and an interface to connect physical machine consoles						
			C Classroom Management Software - Device management software to enhance digital learning. -						

Appendix - G

Revised Section 6 for Package 0152

As per existing Bid Document						Revised			
SI No	Item No	Item	Specification	Qty	Unit	Item	Specification	Qty	Unit
			Compatible with all major operating systems like Windows, Chrome OS, macOS and iOS, so schools can support transformational learning through a mixed platform digital learning environment. - Allowing multiple different devices to be monitored and managed from a single view. - Real-time visibility of every student's screen, classroom control, instructional and monitoring tools, teachers must have visibility of						

Appendix - G

Revised Section 6 for Package 0152

As per existing Bid Document						Revised					
SI No	Item No	Item	Specification	Qty	Unit	Item	Specification	Qty	Unit		
			<ul style="list-style-type: none"> what their students are accessing, viewing or creating online. - Real-time monitoring - Messaging & chat - Remote control - Keyword detection - Capture management. - Reporting and analytics 								
3	A3	Digital Twin for Education basic package/Equivalent	<ul style="list-style-type: none"> • Digital Twin Control, the user has all G- and M-functions as well as all technology cycles for programming and simulation at his disposal. • Digital Twin Simulation: The 3D simulation of the Digital Twin is a virtual replication of 	40+1	Nos	Digital CNC Kits for Education basic package/Equivalent	<p>The system should be absolutely in a CKD KIT form & should be modular system, which should allow for countless configurations and CNC applications. The slides of the machines must be equipped with 2A stepper motors. Ideal for the reproduction of work pieces and processing of 3D solid models.</p> <table border="1" style="width: 100%; border-collapse: collapse;"> <tr> <td style="width: 50%; padding: 5px;">(1) MODULAR CNC LATHE KIT (5 nos)</td> <td style="width: 50%; padding: 5px;">SPECIFICATION</td> </tr> </table>	(1) MODULAR CNC LATHE KIT (5 nos)	SPECIFICATION	10+2	Nos
(1) MODULAR CNC LATHE KIT (5 nos)	SPECIFICATION										

Appendix - G

Revised Section 6 for Package 0152

As per existing Bid Document						Revised			
SI No	Item No	Item	Specification	Qty	Unit	Item	Specification	Qty	Unit
			<p>the real machine and allows extensive simulation functions: 3D removal simulation, manual operation of e. g. tailstock, steady rest, tool and pallet change, manual operations, workspace inspection, measuring probes, etc.</p> <p>• Digital Twin (classroom version 40+1) includes the following components:</p> <ul style="list-style-type: none"> - License for 40 workstations and 1 teacher station - Compatible for turning and Milling machines - Control software Fanuc 31i Turn+Mill, Siemens 840D 				<p>3-Jaw-Chuck, precision live centre, tool post and turning tool. Machinable materials: wood, acrylics, wax, non-ferrous and soft metals.</p> <p>Number of Axis: 2</p> <p>Drive: Steppers, 2A, 1.8° Thread</p> <p>Accuracy: 0.05 mm</p> <p>Max. positioning speed: 300 mm/min</p> <p>Travel X/Z 50 mm/145 mm (expandable)</p> <p>3-Jaw-Chuck Clamping capacity 1.8 - 56 mm inside, 12 - 65 mm outside</p> <p>head spindle: 4000 U/min</p> <p style="text-align: center;">Controller Technical Specifications:</p> <p>The pre-installed software allows for loading, manipulating and processing of ISO standard g-code files (RS-274). It also offers an editable tool table and tool path simulation. In addition to the manual also a training book for introduction to CNC and g-code programming is included.</p>		

Appendix - G

Revised Section 6 for Package 0152

As per existing Bid Document						Revised			
S N o	Ite m No	Item	Specification	Qty	Unit	Item	Specification	Qty	Unit
			Turn+Mill, Heidenhain (iTNC 640) Turn+Mill & Fagor 8055 Turn+Mill - 3D workspace simulation 				Software and Drivers : Win (7, 8, 10) OSX (getestet bis OSX 10.15.x), Linux Connectivity : USB, Ethernet, WIFI (optional) Axes controllable: 4 (upgradeable to 6) furhter IOs: 6x input for (limit/end) switches, 1x E-stop, 2x relays, 0-10V control signal Micro steps: 16 Board: 1GHz CPU, 512MB DDR3 RAM, 4GB storage Power supply: External, 110-240 V, 24 V, 5 A		
							(2) MODUL AR CNC 4TH AXIS MILLIN G KIT (5 nos)		
							Number of CNC axes:	04	
							Drive:	Steppers, 2 A, 1.8°	
							Accuracy:	0,07 mm	

Appendix - G

Revised Section 6 for Package 0152

As per existing Bid Document						Revised				
SI N o	Ite m No	Item	Specification	Qty	Unit	Item	Specification	Qty	Unit	
							Max. positioning speed: Travel Z/Y: Travel X-axis: Increment Rotation Axis Increment rotation axis: head spindle:	300 mm/min 50 mm (expandable)/50 mm 145 mm (expandable) $(360^\circ/3200)*0.5 = 0.05625^\circ$ $360^\circ/800/4 = 0,1125^\circ$ 4000 rpm, with 1/8" collet		
							Controller Technical Specifications:			
							The pre-installed software allows for loading, manipulating and processing of ISO standard g-code files (RS-274). It also offers an editable tool table and tool path simulation. in addition to the manual also a training book for introduction to CNC and g-code programming is included.			

Appendix - G

Revised Section 6 for Package 0152

As per existing Bid Document						Revised			
SI N o	Ite m No	Item	Specification	Qty	Unit	Item	Specification	Qty	Unit
							Software and Drivers : Win (7, 8, 10) OSX (getestet bis OSX 10.15.x), Linux Connectivity : USB, Ethernet, WIFI (optional) Axes controllable: 4 (upgradeable to 6) furhter IOs: 6x input for (limit/end) switches, 1x E-stop, 2x relays, 0-10V control signal Micro steps:16 Board: 1GHz CPU, 512MB DDR3 RAM, 4GB storage Power supply: External, 110-240 V, 24 V, 5 A		
							(3) ALL IN ONE ASSEMBL Y KIT WITH LASER ENGRAVI NG, 3D PRINTING AND CNC	SPECIFICA TION	

Appendix - G

Revised Section 6 for Package 0152

As per existing Bid Document						Revised			
SI No	Item No	Item	Specification	Qty	Unit	Item	Specification	Qty	Unit
							CARVING (2 Nos)		
							Parameters		
							Overall Dimensions	285 * 285 * 318mm	
							Adapter Input	100-240V, 50/60Hz, 1.8Amax	
							Adapter Output	12V~6.5A	
							Main Material	aircraft- grade aluminum	
							Operation Panel:	3.5' LCD touch pad	
							3D Printing		
							Nozzle Diameter	0.4 mm	

Appendix - G

Revised Section 6 for Package 0152

As per existing Bid Document						Revised																																							
SI N o	Ite m No	Item	Specification	Qty	Unit	Item	Specification	Qty	Unit																																				
							<table border="1" style="width: 100%; border-collapse: collapse;"> <tr> <td style="width: 60%;">Layer Resolution</td> <td style="width: 20%;">0.05~0.3 mm</td> <td style="width: 10%;"></td> <td style="width: 10%;"></td> </tr> <tr> <td>Nozzle Temperature</td> <td>190~260 °C</td> <td></td> <td></td> </tr> <tr> <td>Heated bed Temperature</td> <td>50~100°C</td> <td></td> <td></td> </tr> <tr> <td>Forming Size</td> <td>X130 * Y130 * Z130mm</td> <td></td> <td></td> </tr> <tr> <td>Applicable Materials</td> <td>PLA, ABS , PC , FLEX</td> <td></td> <td></td> </tr> <tr> <td>Printing Speed</td> <td>10~80mm /s</td> <td></td> <td></td> </tr> <tr> <td>Laser Engraving</td> <td></td> <td></td> <td></td> </tr> <tr> <td>Working Range:</td> <td>X130 * Y130mm</td> <td></td> <td></td> </tr> <tr> <td>Laser Power:</td> <td>0.5W</td> <td></td> <td></td> </tr> </table>	Layer Resolution	0.05~0.3 mm			Nozzle Temperature	190~260 °C			Heated bed Temperature	50~100°C			Forming Size	X130 * Y130 * Z130mm			Applicable Materials	PLA, ABS , PC , FLEX			Printing Speed	10~80mm /s			Laser Engraving				Working Range:	X130 * Y130mm			Laser Power:	0.5W				
Layer Resolution	0.05~0.3 mm																																												
Nozzle Temperature	190~260 °C																																												
Heated bed Temperature	50~100°C																																												
Forming Size	X130 * Y130 * Z130mm																																												
Applicable Materials	PLA, ABS , PC , FLEX																																												
Printing Speed	10~80mm /s																																												
Laser Engraving																																													
Working Range:	X130 * Y130mm																																												
Laser Power:	0.5W																																												

Appendix - G

Revised Section 6 for Package 0152

As per existing Bid Document						Revised			
SI No	Item No	Item	Specification	Qty	Unit	Item	Specification	Qty	Unit
							Supported Materials:		wood, paper products, some plastics, leather, etc.
							CNC Carving		
							Spindle Speed:		12000rpm Max
							Clamping Range of CNC Chuck:		0~4mm
							Size of Standard CNC Bit:		3.175mm * 0.3mm * 30° flat bottom sharp cutter

Appendix - G

Revised Section 6 for Package 0152

As per existing Bid Document						Revised				
SI No	Item No	Item	Specification	Qty	Unit	Item	Specification	Qty	Unit	
							Supported Materials:		wood, plastics, PCB boards and most non- metallic materials	
							(4) 3D Printer Kit (2 nos)		SPECIFICA TION	
							Paramete rs			
							Overall Dimensio ns (Minimu m)		220 * 220 * 250mm	
							Item Weight (Minimu m)		8000 grams	

Appendix - G

Revised Section 6 for Package 0152

As per existing Bid Document						Revised															
SI No	Item No	Item	Specification	Qty	Unit	Item	Specification	Qty	Unit												
							<table border="1" style="width: 100%; border-collapse: collapse;"> <tr> <td style="width: 50%;">Printing Technology</td> <td style="width: 50%;">Fused Deposition Modelling (FDM)</td> </tr> <tr> <td>Features</td> <td>Resume Printing function, Effortless Filament Feed-in</td> </tr> <tr> <td>Materials Supported</td> <td>PLA</td> </tr> <tr> <td colspan="2" style="text-align: center;">Raw material</td> </tr> <tr> <td colspan="2">Machinable Aluminium rods Center punched, ϕ12x100mm, pack of 15pcs</td> </tr> <tr> <td colspan="2">Milling Foam Blocks Prototyping foam, medium density, approx. 24x24x50mm, pack of 30pcs</td> </tr> </table>	Printing Technology	Fused Deposition Modelling (FDM)	Features	Resume Printing function, Effortless Filament Feed-in	Materials Supported	PLA	Raw material		Machinable Aluminium rods Center punched, ϕ 12x100mm, pack of 15pcs		Milling Foam Blocks Prototyping foam, medium density, approx. 24x24x50mm, pack of 30pcs			
Printing Technology	Fused Deposition Modelling (FDM)																				
Features	Resume Printing function, Effortless Filament Feed-in																				
Materials Supported	PLA																				
Raw material																					
Machinable Aluminium rods Center punched, ϕ 12x100mm, pack of 15pcs																					
Milling Foam Blocks Prototyping foam, medium density, approx. 24x24x50mm, pack of 30pcs																					

Appendix - G

Revised Section 6 for Package 0152

As per existing Bid Document						Revised			
SI No	Item No	Item	Specification	Qty	Unit	Item	Specification	Qty	Unit
							<p>Coloured acrylic plates, Cast acrylic, suitable for milling, protective masking on both sides, 50X50x3mm, pack of 30pcs</p> <p>Resource Kit CNC Incl extra hand tools, tooling (end mills, turning tool), spare parts, gibs, var. screws, etc.</p>		

1.0	General Instructions:
1.1	All the literature should be in English Language only.
1.2	The Vendor must provide list of customers to whom they have supplied the model offered in this tender in last five years.
1.3	Vendor should offer detailed technical catalogue of the machine and write up for highlighting special features, specific applications, attachments etc.
2.0	Installation & Commissioning
2.1	The machine to be inspected as per accuracy chart before dispatch at supplier site. The suppliers to prove out the "Test Components" in all aspects. Acceptance and Qualification during Pre-Dispatch Inspection (PDI), at the supplier end. Release of machine for dispatch after successful completion of acceptance test post PDI.
2.2	The complete installation and commissioning must be carried out by the supplier for all the machines at the final destination/premises. A final accuracy test with an identified test component to be conducted by the purchaser/consignee. Final accuracy test report is to be signed jointly by Purchaser/consignee and supplier. Final acceptance would be given after conducting the accuracy test at the installation location.
3.0	Service
3.1	The manufacturer should have established after sales and service network in India.
3.2	The authorised service partner in India (Name & address), must be certified by the manufacturer and shown in the quotation.
3.3	Number of similar machine installed in India in a reputed organisation.
4.0	Warranty
4.1	Three-year on-site warranty for trouble free operation of the machine from the date of final commissioning and acceptance of machine and free services shall be provided for any trouble during this period. During the period of warranty, if any part is to be replaced, Vendor will have to replace it free of cost. Warranty should include all the items supplied against purchase order. During warranty period, vendor should respond to call/email in maximum 24hrs on all working days and vendor service engineer should attend the machine within maximum 10days from the date of the call/email.
5.0	Training
5.1	Training on operations, programming, and maintenance for minimum 15 days after installation and commissioning and one more week after 3 months of commissioning at installation site.

6.0	Documents & Learning Materials
6.1	Machine Manuals
6.2	Mechanical maintenance manual 2 sets each (one hard copy and one soft copy) - soft copy in the control system
6.3	Electrical maintenance manual 2 sets each (one hard copy and one soft copy) - soft copy in the control system
6.4	Operating and Programming Instruction
6.5	Detailed Layout plan to be submitted to the Civil contractor before floor construction
6.6	Installation and Commissioning instructions by supplier
6.7	Quality Test and Accuracy Test Chart Records
6.8	Circuit Diagrams
6.9	Maintenance/Repair Charts
6.10	Preventive Maintenance Instructions
6.11	Lubrication Chart & Lubricant list
6.12	Instruction manual for Maintenance

Procurement of Goods

**Single-Stage: Single-Envelope
Under Shopping**

Government of Odisha

**Skill Development and Technical Education
Department**

(ADB Loan No.3539)

**PKG 0155: Supply of Furniture for Precision
Engineering Labs**

Issued on	:	14 th March 2024
Invitation for Bids No	:	OSDA/WSC/Goods/M8-2024
OCB No	:	PKG-0155
Purchaser	:	Odisha Skill Development Authority
Country	:	India

REQUEST FOR QUOTATION - GOODS (RFQG)

Project Title : Odisha Skill Development Project (OSDP)

Source of Funding : ADB Loan Number: 3539

Contract Ref : **PKG 0155: Supply of Furniture for Precision Engineering Labs**

Date of Issue of Request: **14th March 2024**

To : Open Competitive Bidding (OCB)

Sir/Madam:

1. The **Odisha Skill Development Authority, Skill Development and Technical Education Department, Government of Odisha** (Purchaser) hereby requests you to submit price quotation/(s) for the Supply and Services of the following items:

Sl. No.	Item No.	Description	Quantity with Unit	
			PE Labs	Total
PKG 0155: Supply of Furniture for Precision Engineering Labs				
1	1.1	Computer table	5 Set.	5 Set.
2	1.2	Flipchart board with stand	3 Nos.	3 Nos.
3	1.3	Full height cabinet (heavy duty)	3 Nos	3 Nos
4	1.4	HD Workbench with drawer	5 Nos.	5 Nos.
5	1.5	Heavy duty storage shelf	1No	1No
6	1.6	Key Box	2 Nos.	2 Nos.
7	1.7	Lecture table and chair	13 Set.	13 Set.
8	1.8	Metal cabinets half eight	2 Nos.	2 Nos.
9	1.9	Mobile magnetic whiteboard	12 Nos.	12 Nos.
10	1.10	Mobile transport trolley	2 Nos.	2 Nos.

11	1.11	Printer table	4 Nos.	4 Nos.
12	1.12	Shelf for Student bag	14 Nos.	14 Nos.
13	1.13	Steel storage cabinet with drawers	3 Nos.	3 Nos.
14	1.14	Storage Cabinet, Metal, Full Height, Swing Door	4 Nos.	4 Nos.
15	1.15	Storage Cabinet with drawers	4 Nos.	4 Nos.
16	1.16	Storage cart	1 No.	1 No.
17	1.17	Student Chair	300 Nos.	300 Nos.
18	1.18	Student chair	20 Nos.	20 Nos.
19	1.19	Student table	10 Nos.	10 Nos.
20	1.20	Tool crib trolley	36 Nos.	36 Nos.
21	1.21	Tool Trolley	10 Nos.	10 Nos.
22	1.22	Trainer's Chair	4 Nos.	4 Nos.
23	1.23	Trainer's Table	2 Nos.	2 Nos.
24	1.24	Wall mount whiteboard	4 Nos.	4 Nos.
25	1.25	White Board, Wall Mount	2 Nos.	2 Nos.
26	1.26	White Board, Portable	2 Nos.	2 Nos.
27	1.27	Wooden work bench	4 Nos.	4 Nos.
29	1.28	First Aid Box	6 Nos.	6 Nos.
29	1.29	Clock, Wall Hung Type	6 Nos.	6 Nos.
30	1.30	DustBin, classroom	12 Nos.	12 Nos.

31	1.31	Computer Table with cable management as shown (for Double sitting)	50 Nos.	50 Nos.
32	1.32	Mesh Butterfly Low Back Chair	100 Nos.	100 Nos.
33	1.33	Crescent Table for 2 Student Big	20 Nos.	20 Nos.
34	1.34	Chair Pluto without arm rest	80 Nos.	80 Nos.
35	1.35	Rectangle Table for 2 Students	20 Nos.	20 Nos.

To assist you in the preparation of your price quotation the necessary **Supply and Delivery Schedule, Technical Specifications, Form of Quotation** and draft **Contract** are enclosed.

2. If you/your firm, however, falls under any of the following conditions, your proposal shall not be considered:
 - (a) you/your firm are/is not a citizen/national of an ADB member country, or
 - (b) you/your firm have/has been associated with the firm that prepared the design and specifications, or engaged in the preparation of the Project for which the contract that is subject of this request for quotations was identified, or
 - (c) you/your firm are/is owned by the Purchaser, or
 - (d) you/your firm are/is currently sanctioned or temporarily suspended by the Asian Development Bank for a violation of its Anti-corruption Policy (1998, as amended to date), or
 - (e) the importation of goods or services from your country or any payment to persons or entities in your country is prohibited in compliance with a decision of the United Nations Security Council under Chapter VII of the Charter of the United Nations.

3. To be qualified as Substantive Responsive bidder, you must submit duly filled Technical Proposal including following Annexures (formats are attached) and Price Quotation in single envelope:
 - i. Nonrefundable processing fee INR 3000 in form of DD/Banker's cheque in favour of "**Odisha Skill Development Authority**".
 - ii. Duly Filled Bidder's Information sheet (Annexure 1)
 - iii. Experience as a main Service Provider of at least one **completed** contract in the last 5 calendar years from the date of Quotation Invitation of **INR 12,48,278.00** with nature similar to the items in the supply schedule of this contract. (Annexure 2)
 - iv. Printed catalogues with make (if any) and detail technical specifications of the offered goods/equipment in similar sequence as required by the purchaser.
 - v. If the bidder is different, then Authorization of dealer/distributor/ manufacturer/affiliate, (as the case may be).
 - vi. Duly filled Form of Quotation along with Annexure 1 and 2.

4. Your price quotation should be submitted in accordance with the following instructions, procedures, and the terms and conditions of the **Contract**.

Preparation of Quotations

- (a) Your price quotation/(s) shall be for all the items as described in attached documents and submitted

only in the attached **Form of Quotation** with the priced **Supply, Delivery and Price Schedule**. The currency of quoted prices and payment shall be in **INR**.

- (b) The prices should be quoted for supply and delivery to **World Skill Center, Bhubaneswar**, Odisha and should be accompanied by adequate technical documentation and catalogue(s) and other printed material or pertinent information (in **English** language) for each item quoted, including names and addresses of firms providing after-sales service facilities in Bhubaneswar.
- (c) You shall submit only one set of quotations for the above items. Your quotation must be typed or written in indelible ink and shall be signed by you or your authorized representative. Without a signature in your **Form of Quotation**, your quotation will not be considered further.
- (d) Your quotation(s) should be valid for a period of 120 days from the deadline for submission of the quotation/(s) as indicated below. If you withdraw your quotation during the validity period and/or refuse to accept the award of a contract when and if awarded, then you will be excluded from the list of Service Providers for the project for two years

Submission and Opening

- (e) Your **Form of Quotation** with the priced **Supply and Delivery Schedule** should be submitted by **10th May 2024 at 2:00 PM** with the required documents signed, sealed and addressed to and delivered to the following address:

Purchaser's Address: **Chief Executive Officer, Odisha Skill Development Authority (OSDA), Skill Development and Technical Education Department**

Street address: **Block B, Sector A, Tower, 2010,**

Floor/Room number: **Mancheswar Industrial Estate,**

City: **Bhubaneswar**

ZIP code: **751007**

Country: **India**

Telephone: **+91-674-2580079**

E-mail: **tenders@worldskillcenter.org**

- (f) Price Quotations of only bidders, whose bid is found complete shall be opened in public, in the presence of participating suppliers' representatives who choose to attend on **10th May 2024 at 4:00 PM** and at the following address.

L16 Board Room, WSC, Bhubaneswar, Odisha, India.

Evaluation and Comparison

- (g) Quotations determined to be substantially responsive to this **Request for Quotation** will only be evaluated by comparison of their offer prices. The quotation of the substantive non responsive bidder will not be considered and evaluated. A quotation is not substantially responsive if the bidder does not provide required experience certificate or fails to provide supplementary information if required by the purchaser and the quotation contains material deviations or reservations to the terms, conditions, and specifications in this **Request for Quotation**.
- (h) In evaluating the quotations, the Purchaser will adjust for any arithmetical errors as follows:
 - (i) where there is a discrepancy between amounts in figures and in words, the amount in words will govern; and
 - (ii) where there is a discrepancy between the unit rate and the line-item total resulting from multiplying the unit rate by the quantity, the unit rate as quoted will govern.

If you refuse to accept the correction, your quotation will be rejected.

Award of Contract

- (i) The Purchaser shall award the contract to the Service Provider whose quotation has been determined to be substantially responsive to this **Request for Quotation** and who has offered the lowest price quotation.
- (j) The Service Provider whose quotation has been accepted will be notified by the Purchaser within 120 days from the date of submission of quotation or extended date, whichever is later, through the return of a copy of the **Form of Quotation** with **Acceptance** signed by the authorized representative of the Purchaser.
- (k) The successful Service Provider shall sign the **Contract** governed by the **Contract Terms and Conditions**. [The quoted price shall include all applicable taxes such as GST (Goods and Service Tax)etc. in India]

5. Further information can be obtained from:

Name : Chief Executive Officer,
Address : **Odisha Skill Development Authority (OSDA), Skill Development and Technical Education Department**
Telephone : **+91-674-2580079**
E-mail : **tenders@worldskillcenter.org**

- 6. The Purchaser intends to apply funds from the **Asian Development Bank (ADB)** for eligible payments under the **Contract** resulting from this **Request for Quotation**.
- 7. Under **ADB's Anticorruption Policy** (1998, as amended to date), Service Providers shall observe the highest standard of ethics during the procurement and execution of such contracts. ADB may reject a proposal for award, and may impose sanctions or other remedial actions on parties involved, if it determines that the Service Provider recommended for award or any other party, directly or through an agent, has engaged in corrupt, fraudulent, collusive, coercive, or obstructive practices or other integrity violations in competing for, or in executing, the Contract. At the time of submission of your quotation, you should not be in ADB's sanctions list. A firm/individual shall not be eligible to participate in any procurement activities under an ADB-financed, -administered, or -supported project while under temporary suspension or debarment by ADB pursuant to its Anticorruption Policy, whether such debarment was directly imposed by ADB, or enforced by ADB pursuant to the Agreement for Mutual Enforcement of Debarment Decisions.
- 8. You/your firm, joint venture partners, associates, parent company, affiliates or subsidiaries, including any subcontractors or Service Providers for any part of the Contract, are not, or have never been, temporarily suspended, debarred, declared ineligible, or blacklisted by the purchaser's country, any international organization, and other donor agency.

If so debarred, declared ineligible, temporarily suspended, or blacklisted, please state details (as applicable to each joint venture partner, associate, parent company, affiliate, subsidiaries, subcontractors, and/or Service Providers):¹

- (a) Name of Institution: _____
- (b) Period of debarment, ineligibility, or blacklisting (start and end date): _____
- (c) Reason for the debarment, ineligibility, or blacklisting: _____

1.

9. You/your firm's, joint venture partners', associates', parent company's affiliates' or subsidiaries', including any subcontractors' or Service Providers', key officers and directors have not been [charged or convicted] of any criminal offense (including felonies and misdemeanors) or infractions/violations of ordinance which carry the penalty of imprisonment.

If so charged or convicted, please state details:

- (a) Nature of the offense/violation: _____
(b) Court/Area of jurisdiction: _____
(c) Resolution (i.e. dismissed; settled; convicted/duration of penalty): _____
(d) Other relevant details:

10. You/your firm understands that it is your obligation to notify ADB should you/your firm, joint venture partners, associates, parent company, affiliates or subsidiaries, including any Subcontractors or Service Providers, be temporarily suspended, debarred or become ineligible to work with ADB or any other multilateral development banks, the purchaser's country, international organizations, and other donor agencies, or any of your key officers and directors be charged or convicted of any criminal offense or infractions/violations of ordinance which carry the penalty of imprisonment.
11. Any misrepresentation that knowingly or recklessly misleads, or attempts to mislead may lead to the automatic rejection of the quotation/bid or cancellation of the contract, if awarded, and may result in remedial actions, in accordance with ADB's Anticorruption Policy (1998, as amended to date) and Integrity Principles and Guidelines (2015 as amended from time to time).
12. A bidder shall not have a conflict of interest. All bidders found to have a conflict of interest shall be disqualified.
13. Please confirm by fax/e-mail the receipt of this request and whether or not you will submit the price quotation(s).

Sincerely,

-Sd-

Chief Executive Officer,
Odisha Skill Development Authority (OSDA)
Skill Development and Technical Education
Department, Government of Odisha.
(Purchaser)

FORM OF QUOTATION (Goods)

_____ (Date)

**Chief Executive Officer,
Odisha Skill Development Authority (OSDA),
Address: Block B, Sector A, Tower, 2010,
Mancheswar Industrial Estate,
Bhubaneswar, Odisha
ZIP code: 751007
Country: India
Telephone: +91-674-2580079
E-mail: tenders@worldskillcenter.org**

We offer to execute the _____ [name and number of Contract] in accordance with the **Contract Terms and Conditions** and the priced **Supply and Delivery Schedule** accompanying this Quotation for the Contract Price of _____ [amount in words and numbers] (_____) (**unit cost and item wise total cost is attached at Attachment 1**) [name of currency] _____. We propose to complete the delivery of Goods and Services described in the Contract within the Delivery Time indicated in the priced **Supply and Delivery Schedule**.

This Quotation and your written acceptance will constitute a binding Contract between us. We understand that you are not bound to accept the lowest or any Quotation you receive.

We hereby confirm that this Quotation complies with the Validity of the Offer and Warranty conditions imposed by the **Request for Quotation** document and the **Contract Terms and Conditions**, respectively.

We: (a) are a national of an ADB member country; (b) have not been associated with the firm that prepared the design and specifications of the contract that is subject of this request for quotation; (c) are not owned by the Purchaser; (d) are not currently sanctioned or temporarily suspended by the Asian Development Bank; and (e) to the best of our knowledge, is not prohibited from being contracted in compliance with a decision of the United Nations Security Council.

Name of Service Provider : _____
Authorized Signature : _____
Name of Signatory : _____
Title of Signatory : _____
Address : _____
Telephone Number : _____
Fax Number, if any : _____
Email address (optional) : _____

(Note: Total price to be carried forward to Form of Quotation)

Attachment 1

Item	Description	Unit	Quantity	Unit Price	Total Price	Delivery Schedule
Supply of Furniture for Precision Engineering Labs						
1	PKG 0155: Supply of Furniture for Precision Engineering Labs	All items of the package	1 Set			90 days from contract effective date
2	Related services of above goods as per Foot Note.	For all items	1			
Total Price including Related Services (In Figure)						
Total Price including Related Services (In Words)						

[Note: 1. The schedule may be for a package with several items but requiring a single package price. However, the bidder has to attach the individual cost and details of each item of the package in the separate sheet as a supporting document (Attachment 2) for working out cost of individual item in a package.

2. The Related services includes cost of transportation, loading, unloading, insurance, spare parts for maintenance, tools for operation, cost for 3 year complete warranty, commissioning, staff training.

3. Prices shall be in local currency by including all eligible taxes of purchaser's country.

4. The Purchaser may seek from bidder, any relevant information and details of each individual item and related service.]

(Note: Cost of item 1 and item 2 are to be carried forward to Attachment 1 in appropriate place)

Attachment 2

Rate of individual Items



Sl. No.	Item No.	Description	Quantity with Unit	Item Rate /Unit Excluding tax (in INR)	Item Rate /Unit Including tax (in INR)	Total Cost Including tax (in INR)
Item No 1						
Supply of Furniture for Precision Engineering Labs						
1	1.1	Computer table	5 Set.			
2	1.2	Flipchart board with stand	3 Nos.			
3	1.3	Full height cabinet (heavy duty)	3 Nos			
4	1.4	HD Workbench with drawer	5 Nos.			
5	1.5	Heavy duty storage shelf	1 No			
6	1.6	Key Box	2 Nos.			
7	1.7	Lecture table and chair	13 Set.			
8	1.8	Metal cabinets half eight	2 Nos.			
9	1.9	Mobile magnetic whiteboard	12 Nos.			
10	1.10	Mobile transport trolley	2 Nos.			
11	1.11	Printer table	4 Nos.			
12	1.12	Shelf for Student bag	14 Nos.			

13	1.13	Steel storage cabinet with drawers	3 Nos.			
14	1.14	Storage Cabinet, Metal, Full Height, Swing Door	4 Nos.			
15	1.15	Storage Cabinet with drawers	4 Nos.			
16	1.16	Storage cart	1 No.			
17	1.17	Student Chair	300 Nos.			
18	1.18	Student chair	20 Nos.			
19	1.19	Student table	10 Nos.			
20	1.20	Tool crib trolley	36 Nos.			
21	1.21	Tool Trolley	10 Nos.			
22	1.22	Trainer's Chair	4 Nos.			
23	1.23	Trainer's Table	2 Nos.			
24	1.24	Wall mount whiteboard	4 Nos.			
25	1.25	White Board, Wall Mount	2 Nos.			
26	1.26	White Board, Portable	2 Nos.			
27	1.27	Wooden work bench	4 Nos.			
29	1.28	First Aid Box	6 Nos.			
29	1.29	Clock, Wall Hung Type	6 Nos.			
30	1.30	DustBin, classroom	12 Nos.			



31	1.31	Computer Table with cable management as shown (for Double sitting)	50 Nos.			
32	1.32	Mesh Butterfly Low Back Chair	100 Nos.			
33	1.33	Crescent Table for 2 Student Big	20 Nos.			
34	1.34	Chair Pluto without arm rest	80 Nos.			
35	1.35	Rectangle Table for 2 Students	20 Nos.			
Total Cost (INR) in Figure						
Total Cost (INR) in Words						
Item No 2						
Total Cost of Related Services (INR) In Figure						
Total Cost of Related Services (INR) In Words						

Attachment 3

TECHNICAL SPECIFICATIONS

Sr. No.	Item No.	Name of Goods or Related Services	Description	Quantity	UoM
PKG 0155: Supply of Furniture for Precision Engineering Labs					
PE/Furniture					
1	1.1	Computer table	<p>The item consist of 01 No. Table (1.8m(L)X650mm(W) X750mm(H) Approx & Computer chair (2 Nos.)</p> 	5	Set.
2	1.2	Flipchart board with stand	 <p>Dimension : 0.7m(L) X 0.6m (W)X 1800 mm(H)</p>	3	Nos.

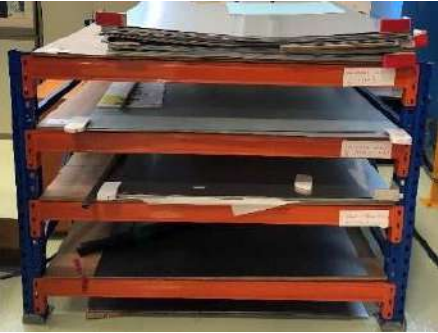

3	1.3	Full height cabinet (heavy duty)	 <p>Colour-Blue, Coating- Epoxy powder coated, Material Thickness-0.6mm before powder coating, No. of shelves-4, Overall size Width-910mm, Overall size Depth-460mm, Overall size Height-1830 mm</p>	3	Nos.
4	1.4	HD Workbench with drawer	<p>Dimension : L-1.5m, W-1.2m, H-0.8m with bench vice swivel base with jaw width 150mm and tightening fixture</p> 	5	Nos.



5	1.5	Heavy duty storage shelf	<p>Dimension: L-1.2m, W-1.2m, H-1m (4 Shelves)</p> 	1	No.
6	1.6	Key Box (Storage of cabinet keys)	 <p>Key Box with 48 Hooks, Large adjustable wall mounts key lock cabinet, White,11 4/5"x9 1/5"x3"</p>	2	Nos.
7	1.7	Lecture table and chair	<p>Lecture table (Wood top/metal frame/(w) drawers) 1.8m (L)X650mm (W) X750mm(H) Approx and computer chair</p> <p>One Set Consist of 01 lecture table and 01 Chair</p>	13	Set.

					
8	1.8	Metal cabinets half eight	 <p>Coating-Epoxy powder coated, Material thickness-0.6mm before powder coating, No. of drawers-7 adjustable Shelves, overall: W-689 mm, D-500 mm, H-954mm</p>	2	Nos.
9	1.9	Mobile magnetic whiteboard	 <p>1.5m x 1m Double sided with castors wheel</p>	12	Nos.



10	1.10	Mobile transport trolley	<p>load capacity 500 kg</p> 	2	Nos.
11	1.11	Printer table	 <p>Dimension : L-600mm, W-450mm, H-750mm Approx.</p>	4	Nos.
12	1.12	Shelf for Student bag	 <p>Can adjust 40 students' bag Material-Wood</p>	14	Nos.



13	1.13	Steel storage cabinet with drawers	<p>Material-Mild Steel,</p> <p>No. of drawers-8, Size-688x458x885 mm (1-4th drawer(20kg),5-6th drawer (25kg,7-8th drawer(45kg))</p> 	3	Nos.
14	1.14	Storage Cabinet	 <p>Metal, Full Height, Swing Door(Approx size: 910mm(W) x 550mm(D) x 1820mm(H))</p>	4	Nos.

15	1.15	Storage Cabinet with drawers		<p>No. of drawers-4, Storage capacity-23 kg, Wheel-Castor, Wheel Type-2 Fixed 2 Swivel Caster, Caster Capacity-272kg, Top Mat-6 mm, Top Drawer-58x39x8 cm, Other Drawer-58x39x14 cm, Caster Dimension-127x50 mm, Size-685x1226x300mm</p>	4	Nos.
16	1.16	Storage cart		<p>Type-Tool Storage, Width-530mm, Height-1260 mm, Finish-Dual Colour Epoxy Powder Coating, Structure-CRCA Sheet, Load Capacity-600 kg, Wheels-PU Wheels, Wheel Size-125x32 mm, Holder Cup-Nylon Cup, Surface Area-700x530 mm, Weight-40 kg</p>	1	No.
17	1.17	Student Chair		<p>Wooden writing pad of Size-450x490x780 mm, Finish-Chrome, Powder Coating</p>	300	Nos.

18	1.18	Student chair	<p>12" Student stack chair with chromed steel leg and nylon swivel glides</p> 	20	Nos.
19	1.19	Student table	<p>1.6m x 0.8m with two rectangular opening for granite surface plate (450mm x 300mm x 20mm) Granite surface plate perfectly fixed with the rectangular opening.</p> 	10	Nos.
20	1.20	Tool crib trolley	 <p>5 drawer type Size-749x520x780 mm, Colour- Red, No. of Drawers-5, Wheel-Castor, Wheel Type-2 Fixed 2 Swivel Caster, Finish- Epoxy Powder Coating</p>	36	Nos.



21	1.21	Tool Trolley	<p>Storage trolley</p>  <ul style="list-style-type: none"> - For tools and accessories - Approx.: L65cm x W45cm x H- 110cm - Aluminium made (Silver steel colour) 	10	Nos.
22	1.22	Trainer's Chair	 <p>Seat material-Fabric, Height-Adjustable, Revolving, Seat shape-curve, Frame Material-Plastic, Chair Base-Chrome, Seating height-20", Chair width-21", Max Seat height-18", Chair depth-18", No. of legs-5, Function-push back and locking</p>	4	Nos.
23	1.23	Trainer's Table	<p>Approx size: 1800mm x 800mm x 750mm. C/w a main switch and a 2-gang, 230V, 13A, socket outlet</p> 	2	Nos.
24	1.24	Wall mount whiteboard	 <p>3.6m x 1.2m</p>	4	Nos.
25	1.25	White Board, Wall Mount	 <p>Approx size: 3600mm(W) x 1200mm(H)</p>	2	Nos.

26	1.26	White Board, Portable	 <p>Approx size: 1400mm(W) x 900mm(H)</p>	2	Nos.
27	1.27	Wooden work bench	 <p>1.5m x 1.2m x 0.8m with bench vice swivel base with jaw width 150mm</p>	4	Nos.
28	1.28	First Aid Box	 <p>Made from GI metal with red and ivory 7-layer powder coating which is rust proof, scratch-proof & corrosion free for long life, made with front transparent acrylic glass and multi compartment 3-shelf for better organize of medicines with security lock on door for safety, Size-32.5(H)X28.5(W)X8(D) CM.</p>	6	Nos.

29	1.29	Clock, Wall Hung Type	<p>Colour-Silver/Golden, Display type-Analog, Style-Contemporary, Special Feature-Silent Clock, Product Dimensions-30WX30H Centimeters, Power Source-Battery Powered, Shape-Round, Material-Plastic, Watch</p>  <p>Movement-Mechanical</p>	6	Nos.
30	1.30	DustBin, classroom	<p>Stainless Steel Dustbin, Plain Pedal Bin with Plastic Bucket and Lid, 8"x13" Garbage Bin, Step-On Trash Can & Round Shape ,10 Liter</p> 	12	Nos.
31	1.31	Computer Table with cable management as shown (for Double sitting)	<p>Computer Table with cable management as shown (for Double sitting) Laminate table top Colour – black Finish- power coated Frame metal - Steel Dimension: 1800 mm(W) X800 mm (D) X 750 mm (H) Surface of table: Finish- powder coated. 1. Power supply provision on table 2 sets of - 2 Switch with twin gang 230V,16/6 A socket outlet. 2.Provision for 2 CPUs, 2 Key Board Trays</p>	50	Nos.

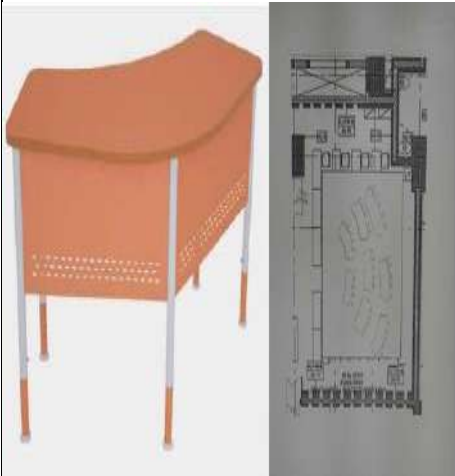
					
32	1.32	Mesh Butterfly Low Back Chair	<p>Specification- Size-H: 1000-1100mm, Seat ht: 460-560mm, D- 600mm, W-590 mm. 5-Prong nylon base for stability. Twin Wheel heavy Duty Castor for easy mobility under load. Seat Hot pressed plywood with steel T-Nuts for rigid fastening with PP cover. Back is moulded Bright Bar with stitched Mesh Cloth. Sturdy steel column gas lift for centre support and seat height adjustment. Telescopic ABS cover over steel column. Lockable synchrony tilt mechanism and with Single piece Die castes PP arm rest adjustable with PP pad. Quality tapestry. High density Moulded PU cushion. Upholstery 0.50 Mtr.</p> <p>Overall appearance of product as shown in picture.</p>	100	Nos.

						
33	1.33	Crescent Table for 2 Student Big		<p>Crescent Table Overall Size- Length- 1634mm, Width- 650/501mm, Height- 750mm, Top made of 25mm thick prelaminated particle board with PVC Edge beading, Front Modesty Panel 2 nos Size- L-750mm, H- 350mm, 0.8mm thick CRCA Sheet, Legs CRCA Pipe Dia 44.5mm, with All Adjustable Leg and Leveller 25mm thickness Total no of legs 5 nos. All steel components are epoxy powder coated after seven tanks anti corrosion treatment of surface. The overall appearance of the product shall be as per photograp.</p>	20	Nos.

34	1.34	Chair Pluto without arm rest	 <p>Size: Total Height-860mm, Width 400mm, Depth-500mm, Seat Height-450mm. Under structure made out of MS cold rolled close annealed tube19mmx1.25mm thick. Fitted with PVC moulded shell. Seat one piece PP moulded shell with ergonomic seating contour. Steel components are epoxy powder coated followed by seven tanks anti corrosion pre-treatment of surface. Or Chrome plated. The overall appearance of the product shall be as per photograph.</p>	80	Nos.
35	1.35	Rectangle Table for 2 Students(<p>Rectangle Table Overall Size- Length-1200mm, Width- 450mm, Height- 750mm, Top made of 18 mm thick Pre laminated plywood with side edge polish in same colour, Legs CRCA Pipe Dia 44.5mm, with Adjustable Leg and Leveller 25mm thickness Total No of 4 Legs. All steel components are epoxy powder coated after seven tanks anti corrosion treatment of surface. The overall appearance of the product shall be as per photograph</p> <p>Front Modesty Panel of 0.8mm thick CRCA Sheet</p> 	20	Nos.

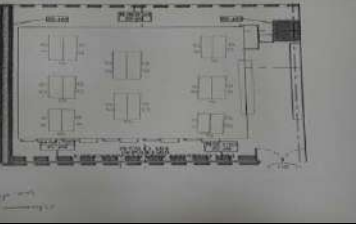
			 <p>A floor plan diagram of a rectangular room. The room contains several tables and chairs arranged in a grid-like pattern. There are labels 'A1-A3' and 'B1-B3' on the walls. A door is visible on the right side. The diagram is drawn in black lines on a light background.</p>		
--	--	--	--	--	--

Letter of Acceptance

To:
M/S
Address
India

Subject: **Notification of Award (Letter of Acceptance) for Package(Name and Number) for World Skill Centre (WSC) at Bhubaneswar**

Contract No. : **Package 0155**

Dear Ma'am/ Sir,

This is to notify that your Bid submitted for Package against IFB dated for Supply of the **for World Skill Centre (WSC) at Bhubaneswar** for the Accepted Contract Amount of **INR (Indian Rupees only; inclusive of Government Charges for Duties and Taxes and other related services)**, as corrected and modified in accordance with the Instructions to Bidders is hereby accepted by OSDA.

You are requested to furnish the unconditional Performance Security of **INR (Indian Rupees only@ 10% (Ten Percent) of the accepted contract amount)** with validity of 40 months from the date of the Letter of Acceptance; along with the duly signed Contract Agreement by the authorized representative of your firm on Stamp Paper of worth INR 200 beforeTemplate of the Contract Agreement with all attachments is included in RFQ document; whereas, Performance Security Form is attached along with this letter.

It may be noted that, after delivery and acceptance of the Goods, the Performance Security shall be reduced to **5% (five percent) of the Contract Price, i.e. INR (..... only)** to cover the Supplier's warranty obligations, which is 36 months from the date of Acceptance Certificate issued by the Purchaser. Accordingly, the Supplier will have to furnish the second unconditional Performance Security of amount INR to cover warranty obligations, which shall be valid for next 36 months after issuance of the Acceptance Certificate. The first Performance Security of 10% amount shall be refunded, once the second Performance Security is submitted by the Supplier.

Attached: Performance Security Format

Authorized Signatory

CEO, OSDA

Performance Security Format

Bank's name, and address of issuing branch or office

Beneficiary: Name and address of the Purchaser

Date:Insert date (as day, month, and year)

Performance Guarantee No.:

We have been informed that name of the Service Provider. (Hereinafter called "the Service Provider") has entered into Contract No. Reference number of the contract dated with you, for the execution of Name of contract and brief description of goods and related services. (Hereinafter called "the Contract").

Furthermore, we understand that, according to the conditions of the Contract, a performance guarantee is required.

At the request of the Service Provider, we name of the bank hereby irrevocably undertake to pay you any sum or sums not exceeding in total an amount of name of the currency and amount in words (. amount in figures.) such sum being payable in the types and proportions of currencies in which the Contract Price is payable, upon receipt by us of your first demand in writing accompanied by a written statement stating that the Service Provider is in breach of its obligation(s) under the Contract, without your needing to prove or to show grounds for your demand or the sum specified therein.

This guarantee shall expire, no later than the day of , and any demand for payment under it must be received by us at this office on or before that date. The Guarantor agrees to extension of the guarantee in response to the Purchaser's written request for any extension. Such extension to be presented to the Guarantor before the expiry of the guarantee.

This guarantee is subject to the Uniform Rules for Demand Guarantees, ICC Publication No. 758 , The supporting statement under Article 15{a} and 15 {b} is hereby excluded.

.....

Signature(s) and seal of bank (where appropriate)

CONTRACT

Name of Country: India

Project Name:

Name of Contract: _____

Contract Number _____

This Contract is entered into on ___[date]___ day of ___[month]___, ___[year], between ___[name of Purchaser]___ (hereinafter called "the Purchaser") on the one part, and ___[name of Service Provider]___ (hereinafter called "the Service Provider") on the other part.

Whereas the Purchaser has requested for quotation for _____ [description of goods] to be supplied by Service Provider in accordance with the **Contract**, and has accepted the Quotation by the Service Provider in the amount of ___ [amount in words] ___ [amount in figures] hereinafter called "the Contract Price".

The Purchaser and the Service Provider agree as follows:

1. The following documents shall be deemed to form and be read and construed as part of this Contract, viz:
 - a) **Form of Quotation, with Supply and Delivery Schedule;**
 - b) **Contract Terms and Conditions;** and
 - c) **Technical Specifications**
2. Taking into account payments to be made by the Purchaser to the Service Provider as provided herein, the Service Provider hereby enters into this **Contract** with the Purchaser to execute and complete the supply of goods under the Contract and remedy any defects therein in conformity with the provisions of this **Contract** and its **Terms and Conditions**.
3. The Purchaser agrees to pay the Service Provider, in consideration of the supply and delivery of the goods and the remedying of defects therein, the **Contract Price** as indicated and accepted in the **Form of Quotation**, under payment terms stipulated in the **Contract Terms and Conditions**.

IN WITNESS whereof the parties hereto have executed the Contract under the laws of Odisha, India [country of Purchaser] on the date indicated above.

Signature and seal of the Purchaser:
For and on behalf of

Signature and seal of the Service Provider:
For and on behalf of

Name of Authorized Representative

Name of Authorized Representative

CONTRACT TERMS AND CONDITIONS

Project Name: Odisha Skill Development Project (OSDP)
Package No.0155

Purchaser: CEO, OSDA

1. Definitions

- (a) "Contract" means the agreement entered into between the Purchaser and the Supplier, together with the Contract Documents referred to therein, including all attachments, appendixes, and all documents incorporated by reference therein.
- (b) "Contract Documents" means the documents listed in the Agreement, including any amendments thereto.
- (c) "Contract Price" means the price payable to the Supplier as specified in the Agreement, subject to such additions and adjustments thereto or deductions therefrom, as may be made pursuant to the Contract.
- (d) "Delivery" means the transfer of the Goods from the Supplier to the Purchaser in accordance with the terms and conditions set forth in the Contract.
- (e) "Completion" means the fulfilment of the delivery and any related service by the Supplier in accordance with the terms and conditions set forth in the Contract.
- (f) "Goods" means all of the commodities, raw material, machinery and equipment, and/or other materials that the Supplier is required to supply to the Purchaser under the Contract.
- (g) "Purchaser" means the entity purchasing the Goods and Related Services, as specified in the SCC.
- (h) "Supplier" means the natural person, private or government entity, or a combination of the above, whose bid to perform the Contract has been accepted by the Purchaser and is named as such in the Agreement, and includes the legal successors or permitted assigns of the Supplier.
- (i) "ADB" is the Asian Development Bank.

2. Applicable Law

- 2.1 The Contract shall be interpreted in accordance with the laws of the Purchaser's country.

3. Language

- 3.1 All communications and documents related to the Contract shall be in English.

4. Assignment

- 4.1 Any assignment of this Contract or of any rights hereunder, in whole or in part without the prior written consent of the Purchaser shall be void.

5. Fraud and Corruption

- 5.1 This Contract shall be covered by the provisions of [ADB's Anticorruption Policy](#) (1998, as amended to date) and [Integrity Principles and Guidelines](#) (2015, as amended from time to time) that requires Borrowers (including beneficiaries of ADB-financed activity), as well as Suppliers and Contractors under ADB-financed contracts, to observe the highest standard of ethics during the procurement and execution of such contracts.

6. Fixed Contract Price

- 6.1 The prices indicated in the Form of Quotation are firm and fixed and not subject to any adjustment during contract performance.

7. Delivery Schedule

7.1 The delivery and related services should be completed as per schedule indicated in the **Supply and Delivery Schedule** but not exceeding 90 days from the contract effective date..

8. Required Technical Specifications (with attachments as necessary)

- (a) General Description
- (b) Specific details and technical standards
- (c) Printed catalogues with make (if any) and detail technical specifications of the offered goods/equipment in similar sequence as required by the purchaser.
- (d) If the bidder is different, then Authorization of dealer/distributor/ manufacturer/affiliate, (as the case may be).
- (e) Performance Parameters

Supplier confirms compliance with above specifications.

9. Delivery and Documents

9.1 Upon delivery, the Supplier shall provide the following documents to the Purchaser:

- (a) Three copies of the Supplier's invoice showing goods' description, quantity, unit price, and total amount;
- (b) manufacturer's or supplier's three year's complete warranty certificate; and
- (c) Certificate of origin.
- (d) **Test report and Third party inspection report from authorized representative of purchaser.**
- (e) Any other document, if required

If goods are coming by courier, supplier shall also provide prior to delivery, copies of documents that will enable Purchaser to receive the goods. The above documents shall be received by the Purchaser at least one week before arrival of the goods and, if not received, the Supplier shall be responsible for any consequent expenses.

10. Taxes and Duties

10.1 The Supplier shall be entirely responsible for all taxes, duties, license fees, etc., incurred until delivery of the contracted Goods to the Purchaser.

11. Payment

11.1 Payment of the contract price shall be made in the following manner:

- (a) 90% within 45 days after delivery of all goods and completion of related services including installation, commissioning, insurance, warranty certificates, on site in accordance with the contract including the required documents; and
- (b) 10% after successful staff training and upon submission of Supplier's claim supported by the acceptance certificate issued by the Purchaser.

12. Warranty

12.1 Goods offered should be covered by manufacturer's complete warranty for 36 months from the date of acceptance certificate issued by the Purchaser. The Performance Security shall be returned

to the Supplier not later than 28 days following the successful discharge of the warranty obligations by the Supplier.

13. Defects

13.1 All defects will be corrected by the Supplier without any cost to the Purchaser within 30 day from the date of notice by Purchaser. The name and address of service facility where the defects are to be corrected by the Supplier within the warranty period are:

**World Skill Center,
Block B, Sector A, Tower, 2010,
Mancheswar Industrial Estate,
Bhubaneswar, Odisha
ZIP code: 751007
Country: India**

14. Resolution of Disputes

14.1 The Purchaser and the Supplier shall make every effort to resolve amicably by direct informal negotiation any disagreement or dispute between them under or in connection with the Contract. In the case of an unresolved dispute between the Purchaser and the Supplier, the dispute shall be settled in accordance with the provisions of the Laws of India.

15. Failure to Perform

15.1 The Purchaser may without prejudice to all its other remedies under the Contract, deduct from the Contract Price, as liquidated damages, a sum equivalent to the 1.0 % percentage of the Contract Price for each week or part thereof of delay until actual delivery or performance, up to a maximum deduction of 10 % of the Contract Price . Once the maximum is reached, the Purchaser may terminate the Contract.

16. Force Majeure

16.1 The supplier shall not be liable for penalties or termination for default if and to the extent that it's delay in performance or other failure to perform its obligations under the Contract is the result of an event of Force Majeure.

(a) For purposes of this Clause, "Force Majeure" means an event beyond the control of the Supplier and not involving the Supplier's fault or negligence and not foreseeable. Such events may include, but not restricted to, act of Purchaser in its sovereign capacity, wars or revolutions, fires, floods, epidemics, quarantine restrictions, and freight embargoes.

(b) If a Force Majeure situation arises, the Supplier shall promptly notify the Purchaser in writing of such condition and the cause thereof. Unless otherwise directed by the Purchaser in writing, the Supplier shall continue to perform its obligations under the Contract as far as is reasonably practical and shall seek all reasonable alternative means for performance not prevented by Force Majeure event.

17. Termination Due to Integrity Violation

17.1 The Purchaser may terminate this Contract, in whole or in part, if the Supplier, in the judgment of the Purchaser has engaged in integrity violations in accordance with Clause 5 [Fraud and Corruption], in competing for or in executing this Contract.

18. Accounts and Records

18.1 The Supplier shall keep accurate and systematic accounts and records in respect of the delivered goods in such form and detail as are customary in the industry, for a period of no less than 3 years after the expiration or termination of this Contract.

19. Suspension of ADB Loan or Credit

- 19.1 In the event that ADB suspends the Loan or Credit to the Purchaser, from which part of the payments to the Supplier are being made,
- (a) The Purchaser is obligated to notify the Supplier, with copy to the Purchaser's representative, of such suspension within 7 days of having received ADB's suspension notice.
 - (b) If the Supplier has not received sums due it within the 28 days for payment provided for in Clause 11 [Payments], the Supplier may immediately issue a 14-day termination notice.

(Note: Duly filled to be submitted by Bidder with name, signature and official stamp)

Annexure 1

Form: Bidder's Information Sheet

Bidder's Information	
Bidder's legal name	
In case of a Joint Venture, legal name of each partner	
Bidder's country of constitution	
Bidder's year of constitution	
Bidder's legal address in country of constitution	
Bidder's authorized representative (name, address, telephone number(s), fax number(s) and e-mail address)	

(Note: Duly filled to be submitted by Bidder with name, signature and official stamp)

Annexure 2

Form: Contractual Experience

Contractual Experience			
^a Contract No of	Contract Identification		
Award Date		Completion Date	
Role in Contract	<input type="checkbox"/> Manufacturer	<input type="checkbox"/> Service Provider	
Total Contract Amount (INR)			
If partner in a joint venture or subcontractor, specify participation of total contract amount	Percent of Total	Amount	
Purchaser's name Address Telephone/Fax Number E-mail			
Description of the Similarity in Accordance with Criteria 2.3.1 (Contract Type B) of Section 3 (Evaluation and Qualification Criteria)			

^a1. Bidder as a main Service Provider shall provide evidence of experience of 1 contract of amount **INR 12,48,278.00** of similar nature and complexity within last 5 calendar years from the Request For Quotation (RFQ) date.
 2 Purchaser can ask for any additional document as evidence of Contractual Experience.